



INDUSTRIES, INC.

Installation Instructions For:
AVM System 100
ELASTO FIBERDECK® 100

Table of Contents

PART I-GENERAL	2
1.01 Description	2
1.02 Applicator	2
1.03 Product Delivery and Storage	2
1.04 Project Conditions	2
PART II - PRODUCTS	3
2.01 ELASTO FIBERDECK® 100 System Materials	3
PART III - EXECUTION	3
3.01 Inspection of Plywood Substrates	3
3.02 Inspection of Concrete Substrates	4
3.03 Preparation of Plywood Substrates	4
3.04 Preparation of Concrete Substrate	5
3.05 System Application	5
3.06 Quality Control	8
3.07 Protection of Installed Work	8
3.08 Clean Up	8
3.09 Limitations	8
PART IV - METHOD OF REPAIR	9
4.01 Damage Description:	9
4.02 Damage Description:	9
4.03 Damage Description:	9
4.04 Damage Description:	9
PART V - COVERAGE CHARTS AND SPECIFICATIONS	10
PART VI - DETAILS	11

**Installation Instructions For:
AVM System 100
ELASTO FIBERDECK® 100**

PART I-GENERAL

1.01 Description

The Elasto Fiberdeck® 100 - is Fire Rated as a One Hour, Class A, Traffic Bearing,, Walking and Roof Deck Waterproofing System, which can be applied directly to plywood, concrete, and sheet metal substrates. It is designed for use on roofing, external balconies, patios, walkways, stairs, courtyards, sun decks and pool decks. Elasto Fiberdeck® 100 is also an excellent repair material in these applications.

1.02 Applicator

The applicator shall be approved by AVM Industries and be completely experienced in the application of the materials of this system.

1.03 Product Delivery and Storage

A. Delivery: Deliver all products to the project site in their original, sealed containers or packaging, with manufacturer's name and label intact.

B. Storage and Handling

1. Handle and store containers in accordance with printed instructions.
2. Do not store materials in direct sunlight or where they might be damaged by rain or water.
3. All system components shipped in bags must be stored in a cool DRY place.
4. Keep all materials out of reach of children.
5. If irritation occurs during use, liberally flush the skin with water and see a physician.

1.04 Project Conditions

- A.** Do not apply materials at temperatures below 50° F and falling or if precipitation is imminent. Do not apply materials at temperatures above 90° F or rising.
- B.** Warn personnel against hazards of materials to the skin and eyes. The fiberglass mat can be an irritant to bare skin and the AVM can cause injury to the eye if splashed into them.
- C.** No special protective gear is required during the application of the system materials, except for eye protection such as safety goggles and a dust mask while handling and during the initial coating of the fiberglass fabric.
- D.** Protect adjacent surfaces which could be damaged during the application procedure.
- E.** The deck substrate shall be properly sloped to freely drain and eliminate the ponding of water.

**Installation Instructions For:
AVM System 100
ELASTO FIBERDECK® 100**

PART II - PRODUCTS

2.01 ELASTO FIBERDECK® 100 System Materials

A. AVM Crete 6400

AVM Crete 6400: A pre-proportioned Kit consisting of AVM Aggregate 400 and AVM Concrete Additive 7400.
AVM Aggregate 400: 50 pound bag of AVM Aggregate 400. (Cementitious)
AVM Concrete Additive 7400: 1.00/5.00 Gal containers of the AVM Concrete Additive 7400 Liquid.
AVM Metal Lath 2.5#: Electro Galvanized metal lath 2.5LBS per sq/yard ICBO 4135, ASTM 8924. (28"x96" each, in bundles of 10)

Elasto Fiberdeck® 100 Membrane

B. Primer: AVM Primer 100, suitable for wood, concrete, and sheet metal substrates.

C. Membrane:

AVM Membrane 100 consists of:

1. AVM Mat 100, Multi-directional chopped strand fiberglass mat, minimum weight of 3/4 ounce per square foot.
2. AVM Base Resin 100, Integral color acrylic base coat resin.

E. Texture Coat:

AVM Texture 100, A pre-mixed, ready to use Texture coating.

F. Top Coat:

AVM Top Coat Sealer 4100, integral color or clear top coat acrylic system sealer.

G. Caulking:

Construction Grade quality sealant, compatible with system materials, as manufactured by Sika (Sika Flex 1a) or equal for sealing of perimeter joints and other waterproofing system discontinuities.

H. Patching Compound: AVM Acripatch 5020, (medium duty) for application at joints, voids, cracks, and wood knots not exceeding 1/4 inch maximum thickness. AVM Acripatch 5010 (fine) and 5030 (heavy duty) may be used when needed.

PART III - EXECUTION

3.01 Inspection of Plywood Substrates

- A.** Plywood must be at least 5/8 inch thick, Exterior Grade, Structural plywood with maximum span of 16" between supports. All plywood edges must be properly supported and fastened to the support structure below. Joints must be properly blocked. All nails or screws shall be flush to the plywood surface or slightly sunk in. Plywood to have 1/8 inch spacing between sheets, installed perpendicular to the supports below and installed per code.
- B.** Plywood substrate shall be clean, free of dirt, dust, oil, grease and other materials that can prevent or reduce the bonding of the system to the plywood.
- C.** Plywood shall be securely attached with glue to wood beams and joists. In lieu of glued connections, screw or nail plywood with non-rising, ring shank nails spaced at 6 inches on centers maximum.

**Installation Instructions For:
AVM System 100
ELASTO FIBERDECK® 100**

3.01 Inspection of Plywood Substrates (Cont.)

- D.** Damaged plywood substrate areas with noted defects or deflections shall be repaired or replaced prior to commencement of deck system application.
- E.** Verify that substrate provides adequate slope for proper drainage. (Minimum slope required is 1/4" per foot)
- F.** Verify that all sheet metal flashing and related accessories are properly secured and joints solidly imbedded in sealant. Install Galvanized or preferably Bonderized edging metal where shown or required for a complete installation.
- G.** It is recommended to install the Wall-To-Deck sheet metals (Diatto Deck, Zee Bars, etc.) over the AVM Crete, if possible. If the metals are already in place, install the AVM Crete over them.

3.02 Inspection of Concrete Substrates

- A.** Concrete substrate shall be clean, free of dirt, dust, oil, grease and curing agents.
- B.** Concrete finish shall be straight without waviness or noted defects, troweled and finished with a light broom surface texture.
- C.** Concrete shall have a minimum 28 day cure time and shall have achieved a minimum compression strength of 2000 psi.
- D.** Damaged concrete surfaces with noted defects shall be repaired prior to commencement of the deck system application.
- E.** Verify that concrete slab or topping provides adequate slope for proper drainage. (Minimum slope 1/4" per foot)
- F.** Verify that all sheet metal flashing and related accessories are properly secured and joints solidly imbedded in sealant. Install edging metal where shown or required for a complete installation.
- G.** Expansion Joints: If expansion joints exist, contact AVM Industries for further instructions on how they should be handled. You may also refer to supplied details for suggested waterproofing methods of the expansion joints.

3.03 Preparation of Plywood Substrates

- A.** Clean (scrape if necessary) all sheet metal areas to receive the deck coating. Sheet metals made out of Galvanized or Bonderized Steel need to be wiped clean using a rag and water mixed with a strong detergent. (Make sure all oil residues are removed)
- B.** Caulk all exposed sheet metal joints, and other hard to reach areas. Especially areas prone to leaking . Special attention should be given to the following areas: Corners, around drains and scuppers, voids, holes, and around posts.
- C.** Seal plywood joints and cracks flush with the AVM Acripatch 5020 patching compound. (Required for 1-hour fire rating)
- D.** Thoroughly clean the areas to receive the Elasto Fiberdeck® 100 system with a blower to remove all dust and debris.

**Installation Instructions For:
AVM System 100
ELASTO FIBERDECK® 100**

3.04 Preparation of Concrete Substrate

- A. Remove latex, oil, grease, curing agents, debris and other deleterious materials from surfaces scheduled to receive application. High pressure washing or acid washing are highly recommended, if needed.
- B. Clean hairline cracks and rout out cracks larger than 1/8 inch. Seal cracks and joints flush with the AVM Acripatch 5020 patching compound.
- C. Just prior to beginning the installation of the deck system, thoroughly clean the areas to receive this work with a blower to remove all debris and dust from the work area.
- D. Expansion joints are a very critical, yet sensitive area to be waterproofed and can fail if not properly handled. There are many different methods to waterproof expansion joints. To ensure system compatibility and water tightness AVM Industries must pre approve the suggested expansion joint's waterproofing method(s). Therefore, please submit to us the expansion joint's details in the architectural drawings, the "Spec Book" and any other available sources for pre approval.

3.05 System Application

Important Note: The following material coverages may vary based on job conditions, Substrate conditions and other factors. Please read the coverage chart carefully prior to the application of the Elasto Fiberdeck® 100 System.

Installing the AVM Crete 6400

Installing the AVM Crete on Existing Concrete Slabs: (Optional) (Steps A & C) Read Instructions Carefully!

It is not necessary to install the AVM Crete on existing reinforced cement slabs exceeding 1" in thickness and 2000 PSI. (To skip the AVM Crete 6400 installation, proceed to Step D of section 3.05, below) If the existing slab is rough, uneven or needs its slope improved, you may install the AVM Crete 6400 by following steps A and C of section 3.05. On existing reinforced concrete slabs exceeding 1" in thickness and 2000 PSI, the AVM Crete 6400 may be worked down to the smallest thickness achievable with the trowel or float. For best results however, do not go under 1/8" in thickness.

Installing the AVM Crete over Plywood Surfaces - Steps A, B & C are required!

- A. **Primer:** Apply AVM Primer 100 to all plywood, sheet metal or concrete surfaces scheduled to receive the AVM Crete 6400. Apply at the rate of approximately one (1) gallon per 200-300 square feet. Allow primer to cure until dry. (approximately 15-45 minutes depending on temperature and wind conditions) Cover all primed areas with AVM Crete 6400 within 12 hours of initial primer application or re priming shall be required.
- B. **Metal Lath:** Lay out the AVM Metal Lath 2.5# on the entire plywood area to receive the AVM Crete. Do NOT overlap sheets. Terminate the AVM metal lath 2.5# ¼ inch away from any flashing metals. Fasten the AVM Metal Lath 2.5# sheets by stapling them to the deck using 16 gauge Galvanized staples (or other non rusting type) with 1 inch crown and 5/8" inch long legs at the rate of 16 staples per square foot.

Seems: Lay the sheets of the AVM Metal Lath 2.5# as close as possible to each other without overlapping them. (Maximum distance between sheets should not exceed ¼ inch). Staple the sheets together at the rate of one staple per inch (one inch on center), and by shooting one leg of the staple into one sheet and the other staple leg into the other sheet, thus tying both sheets together.

Drains: The layout of the AVM Metal Lath 2.5# depends on the type of drain. Make sure that the water will flow over the lath and into the drain. Do not allow the water to go anywhere but into the drain.

**Installation Instructions For:
AVM System 100
ELASTO FIBERDECK® 100**

Installing the AVM Crete over Plywood Surfaces - Steps A, B & C are required! (Cont.)

- C. AVM Crete:** Apply the AVM-Crete only at temperatures ranging from 50°-90°F. Mix one bag of the AVM Aggregate 400 with one gallon of the AVM Concrete Additive 7400 using an electric drill and paddle. **Mix Well!** Apply the AVM Crete by using a trowel or float. Make sure all the holes in the metal lath are covered. The AVM Crete may be worked down to a minimum total dry thickness of ¼ inch. **DO NOT** apply more than 1.0" in thickness. If more than 1.0" in thickness of the AVM Crete 6400 is required, add ½ gallon (approximately 7 pounds) of dry 1/4" Pete Gravel to each mix of 1 gallon of AVM Concrete Additive 7400 and one bag of AVM Aggregate 400. (Fill ½ of an empty AVM Concrete Additive 7400 plastic bottle with the dry ¼ inch Pea Gravel, and add it to the mix.)

Curing Time: For AVM Crete ½ inch thick or less allow 24-48 hours curing time. For AVM Crete over ½ inch thick allow a minimum of 72 hours curing time. (The curing times are based on nice sunny days reaching 75°F and no more than 50% relative humidity. Actual curing times may vary based on weather conditions) Do not proceed to the next step if the AVM Crete is not sufficiently cured.

Installing the Elasto Fiberdeck® 100 waterproofing system

- A. Cleaning:** Lightly scrape the surfaces to receive the Elasto Fiberdeck® 100 system. Fix imperfections, if any. Then thoroughly clean the AVM Crete or other surfaces using a broom or (preferably) a blower.
- B. Patching:** Apply the AVM Acripatch 5020 using a scraper or trowel at the edges of the AVM Crete and where hairline cracks and other imperfections exist. In the areas where the AVM Crete is terminated ¼ inch from sheet metals, make sure the AVM Acripatch 5020 goes from the point of the AVM Crete termination to the sheet metal, covering at least half the width of the sheet metal. Allow the AVM Acripatch sufficient time to dry. (*Do not exceed 1/8th" per lift, and maximum 1/4" thick*)
- C. Cleaning:** Once cured, lightly scrape the AVM Acripatch 5020. Fix imperfections if any. Then thoroughly clean the areas to receive the AVM Elasto Fiberdeck® 100, using a broom or (preferably) a blower.
- D. Primer:** Apply AVM Primer 100 to all the surfaces scheduled to receive application. Apply at the rate of approximately one (1) gallon per 200 square feet. Allow primer to cure to complete dryness (approximately 15-45 minutes depending on temperature and wind conditions) before base membrane is applied. Cover all primer within 12 hours of initial application or re priming shall be required.
- E. Fiberglass Mat:** Lay out the AVM Mat 100 in shingle fashion, with the top layer at the higher level overlapping the lower level a minimum of 2 inches. Overlap roll material over all sheet metals and other items as follows:

Edge Metal: Terminate the mat approximately ½ inch from the edge metal's edge. (Minimum 1inch overlap required)

Diato Deck Metal: Roll up the mat until it reaches the stucco stop or a minimum 1 inch high.

Other: Overlap mat 2", in such a way that once the waterproofing membrane is cure, water will not be able to penetrate the structure.

Drains: Mat layout depends on the type of drain. Make sure that the water will flow over the mat and into the drain. Do not allow the water to go anywhere but into the drain. Refer to drain manufacture's details as well.

1. Before applying the AVM Base Resin 100, cut out all bubbles and replace damaged fiberglass mat as required.
2. For better look, feather out fiberglass joints and check corners and edges for gaps, twists, or other damage.
3. Repair or replace the fiberglass mat as required.

**Installation Instructions For:
AVM System 100
ELASTO FIBERDECK® 100**

- F. Base Coat Resin:** Apply the AVM Base Resin 100 over the AVM Mat 100 at the rate of 40-50 square feet per gallon. Work the AVM Base Resin 100 into the fiberglass mat using a roller and a brush. Apply sufficient pressure to the roller to thoroughly embed the AVM Base Resin 100 into the fiberglass mat. Allow the base coat membrane (Membrane = Mat + Base Resin) to cure at least overnight. Prior to resuming work, verify that the base coat membrane is thoroughly dry.
- G. Base Coat Membrane Inspection**
1. After the base coat membrane has cured, carefully inspect the surface for bubbles located at the fiberglass joints or within the field area. In addition, thoroughly check the membrane for pinholes in the base coat membrane's surface.
 2. If bubbles are found, remove the bubbles and surrounding area by cutting them out and reinstalling the base coat membrane per the base coat membrane installation instructions.
 3. Remove blotches, clumps and other imperfections using a scraper or a knife. If necessary, re install a small piece of the base coat membrane per the base coat membrane installation instructions.
 4. Carefully inspect the membrane for pinholes. (The membrane should be completely uniform without pinholes) If pinholes are found, apply a second coat of the AVM Base Resin 100 at the rate of one (1) gallon per 100-150 square feet, or until the pinholes are sealed.
 5. Thoroughly clean the base coat membrane by broom or (preferably) by blower. If you wish, you may apply a thin coat of the AVM Acripatch 5020 at fiberglass seams and in other areas where imperfections still exist. (This helps make the deck coating look more uniform once completed)
- H. Texture Coat:** Thoroughly clean the base coat membrane by broom or (preferably) by blower. Spray, trowel, roll or use a commercial grade soft sponge to apply the AVM Texture 100, at the rate of one (1) gallon per 40-60 square feet. (See coverage chart for different types of textures) If spraying, adjust the spray nozzle to apply the material to match the approved sample. Optional troweled, knock down, design, and other finishes may be applied. Allow the texture coat to properly cure prior to walking on the textured areas. After curing, remove all masking materials. Then lightly scrape the texture coat with a scraper and remove all the residue (preferably by blower) prior to beginning the application of the AVM Top Coat Sealer. A second coat of the AVM Texture 100 may be applied to achieve a denser coverage.
- I. Top Coat Sealer:** Thoroughly clean the deck areas prior to applying the AVM Top Coat Sealer. Apply the AVM Top Coat Sealer over the cured texture coat at the rate of 100-120 square feet per gallon. Allow the AVM Top Coat Sealer to cure for several hours. (Preferably, 24 hours) If you cannot wait 24 hours, light foot traffic may be allowed when the AVM Top Coat Sealer is no longer tacky. A second layer of the AVM Top Coat Sealer will add strength and longevity in addition to making the color look richer.

Important Notes: For better results, apply the AVM Top Coat Sealer early in the morning when the temperatures are cooler. (Especially when applying the AVM Top Coat Sealer to Non Shaded areas) Apply the AVM Top Coat Sealer "Wet on Wet"!! Applying new (wet) AVM Top Coat Sealer over cured AVM Top Coat Sealer will create two different shades. A second coat of the AVM Top Coat Sealer will make the deck color look richer and will provide extra protection as well.

**Installation Instructions For:
AVM System 100
ELASTO FIBERDECK® 100**

3.06 Quality Control

- A.** Visually inspect all coated surfaces to ensure a full and proper coating application, especially at corners, drainage scuppers and hard to reach areas.
- B.** All unsatisfactory areas shall be repaired prior to final acceptance.

3.07 Protection of Installed Work

- A.** The completed system shall be protected from all pedestrian traffic for the first 24 hours after application.
- B.** Protect completed system from "heavy" pedestrian and wheeled traffic for the next 72 hours.

3.08 Clean Up

- A.** At completion of installation remove all temporary protection and barricades from the work.
- B.** Clean entire work area or where needed. Repair all damage or remove and replace work which cannot be repaired. Touch up all marred and abraded surfaces.

3.09 Limitations

The Elasto Fiberdeck® 100 system materials have been tested and approved to be installed directly over sheet metal substrates. However, AVM Industries does not recommend to install this system over substrates consisting only of sheet metals or substrates containing large sheet metal areas. If you wish to install this system over large sheet metal areas, please consult AVM Industries Technical Support department prior to proceeding with such an installation. Failure to do so could void the system's warranty!

**Installation Instructions For:
AVM System 100
ELASTO FIBERDECK® 100**

PART IV - METHOD OF REPAIR

Repairing Damage to the Elasto Fiberdeck® 100 Waterproofing System (Substrate is not damaged)

4.01 Damage Description: Top coat is stained, peeling, cracking or is simply very old. (Texture Coat is not damaged)

Method of Repair:

1. Scrape off any loose top coat using a scraper or and a stiff brusK.
2. Remove anything that might prohibit bonding of the new Top Coat Sealer. (High pressure washing is recommended)
3. Re-coat the damaged areas with new AVM Top Coat Sealer 4100. See Section 3.05 item 'L' for application instructions.

4.02 Damage Description: Texture and Top Coat are damaged or peeling, yet the fiberglass membrane is not damaged.

Method of Repair:

1. Scrape off any loose texture or top coat using a scraper or and a stiff brush.
2. Remove anything that might prohibit bonding of the new materials. (High pressure washing is recommended)
3. Apply new texture where needed. See Section 3.05 item 'K' for application instructions.
4. Re-coat the damaged areas with new AVM Top Coat Sealer 4100. See Section 3.05 item 'L' for application instructions.

4.03 Damage Description: The entire Elasto Fiberdeck® 100 is damaged or peeling yet the substrate is not damaged.

Method of Repair:

1. Scrape off any loose Elasto Fiberdeck® 100 coating using a scraper. You may also use a sharp knife to cut out and then peel off any bad sections. Make sure to remove all coating that is not securely bonded to the substrate below!
2. Remove/peel off anything that might prohibit bonding of the new materials. (High pressure washing is recommended)
3. Apply the new Elasto Fiberdeck® 100 system where needed. See Section 3.05 items 'D' thru 'L' for application instructions.

4.04 Damage Description: The Elasto Fiberdeck® 100 is damaged or peeling and the substrate is damaged as well.

Method of Repair:

1. You MUST contact AVM Industries or an authorized AVM Industries installer to review the damage. Since the substrate is damaged, the repairs must be done very carefully to ensure the Fire Resistance and the Structural Strength of the damaged deck areas are not compromised!

*** END OF SECTION 07115, Installation Instructions for Elasto Fiberdeck® 100 ***

Version: May 21, 2000

See Technical Data, Specifications and Coverage Chart on the following page.

**Installation Instructions For:
 AVM System 100
 ELASTO FIBERDECK® 100**

PART V - COVERAGE CHARTS AND SPECIFICATIONS

The following coverages are based on controlled tests. Actual coverages may vary.

Materials	One Kit Makes	One Kit Covers at 1/8" Thick	One Kit Covers at 1/4" Thick	One Kit Covers at 1/2" Thick
AVM Crete 6400	4 Gallons of Mixed Product	40 Square Feet	20 Square Feet	10 Square Feet
Weight of 1 sq. ft. of Crete 6400 installed and Cured		@ 1/8" thick = ~1.25 Lbs	@ 1/4" thick = ~2.50 Lbs	@ 1/2" thick = ~5.00 Lbs

Materials	Over Plywood	Over Concrete	Over Sheet Metal
AVM Primer 100	200-300 Sq. Ft./Gal.	200-300 Sq. Ft./Gal.	200-300 Sq. Ft./Gal.
AVM Base Resin 100	40-50 Sq. Ft./Gal.	40-50 Sq. Ft./Gal.	40-50 Sq. Ft./Gal.
AVM Matt 100	Allow 10-20% waste	Allow 10-20% waste	Allow 10-20% waste
AVM Texture 100 Sprayed Sand Finish	40-60 Sq. Ft./Gal.	40-60 Sq. Ft./Gal.	40-60 Sq. Ft./Gal.
AVM Texture 100 Sprayed Knock Down Finish	40-60 Sq. Ft./Gal. depending on the desired look	40-60 Sq. Ft./Gal. depending on the desired look	40-60 Sq. Ft./Gal. depending on the desired look
AVM Texture 100 Troweled Smooth	35 Sq. Ft./Gal.	35 Sq. Ft./Gal.	35 Sq. Ft./Gal.
AVM Top Coat Sealer 1 st coat	100-120 Sq. Ft./gal	100-120 Sq. Ft./gal	100-120 Sq. Ft./gal
AVM Top Coat Sealer 2 nd Coat	150 Sq. Ft./gal	150 Sq. Ft./gal	150 Sq. Ft./gal

Technical Data - AVM System 100®		General Data - AVM System 100®	
Fire Rating	Class A + 1 Hour over 2"x8" Joists	Shelf Life: (All Components)	One year in original unopened packaging. Mats & metals may have longer life if in good condition.
Weatherometer	No Cracking, Softening, Cracking	Storage Conditions:	Store dry at 50-90F. If frozen, discard
Abrasion	4.58% (Pass)	Cement Mixing Ratio:	Manufactured in a pre-proportioned kit.
Wind Uplift	Over 135 Lbs/Sq. Ft. or ~227 MPH.	Cement Color:	Gray
Bond Strength (Once Cured)	134 PSI	Base / Texture Colors:	4 Standard and many Custom
Compressive Strength: ASTM C39,C172,C192,C470	7 Days: 2500 PSI 28 Days: 4000 PSI	Top Coat Colors: Standard: Custom:	20 Standard colors Custom colors are available - Min 50 Gal
Minimum Dry Thickness - Complete System: 0.310". (AVM Crete 6400 must be at least 0.250" thick when dry)			

Packaging:	
AVM Acripatch 5020	2.0 / 5.0 Gal Pails
AVM Aggregate 400	50 LB Bag
AVM Additive 7400	1.0 / 5.0 Gal pails
AVM Metal Lath 2.5#	10 sheets/bundle
AVM Primer 100	2.0 / 5.0 Gal pails
AVM Base 100	2.0 / 5.0 Gal pails
AVM Texture 100	2.0 / 5.0 Gal pails
AVM Top Coat 4100	2.0 / 5.0 Gal pails

Approximate Shipping Weights:	
AVM Acripatch 5020	2.0/5.0 Gal 15 / 39 Lbs.
AVM Aggregate 400	50 Lbs./Bag
AVM Additive 7400	1.0/5.0 Gal 9/46 Lbs.
AVM Metal Lath 2.5#	5 Lbs./sheet
AVM Primer 100	2.0/5.0 Gal 18 / 46 Lbs.
AVM Base 100	2.0/5.0 Gal 18 / 46 Lbs.
AVM Texture 100	2.0/5.0 Gal 23 / 56 Lbs.
AVM Top Coat 4100	2.0 / 5.0 Gal 19 / 47 Lbs.

See details on next page:

Installation Instructions For:
AVM System 100
ELASTO FIBERDECK® 100

PART VI - DETAILS

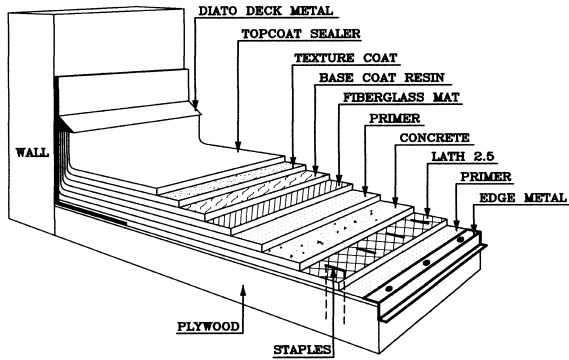

1.1 AVM System 100 - Elasto Fiberdeck® Over Plywood Substrate

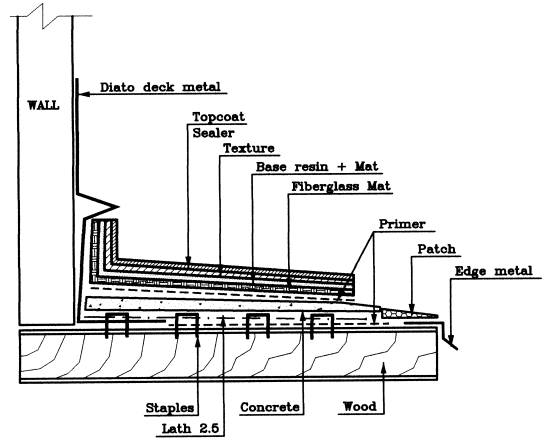

1.2 AVM System 100 - Elasto Fiberdeck® Over Plywood Substrate

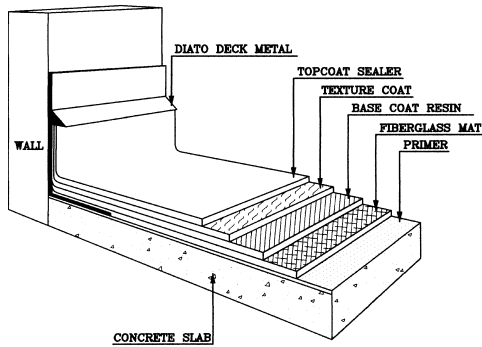

1.3 AVM System 100 - Elasto Fiberdeck® Over Concrete or Plywood Substrates

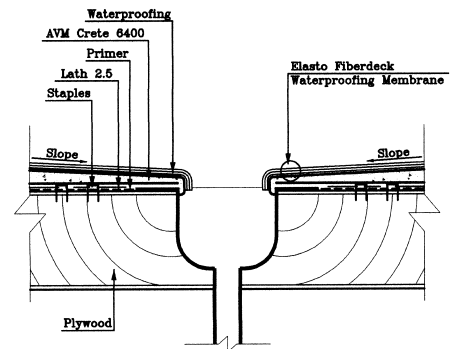

90.1a Elasto Fiberdeck® Drain

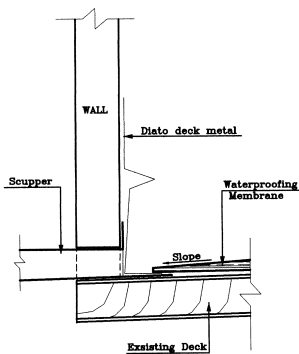

90.3 AVM Scupper

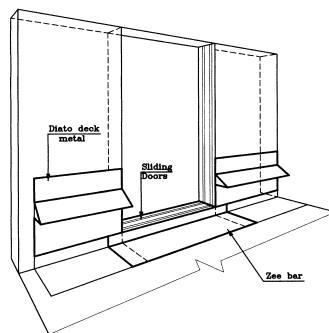

90.4 Sliding Doors / Entry Doors Flashing

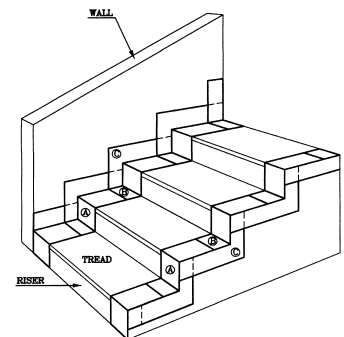

90.7 Sheet Metals (Flashing) for Stairs