



AVM System 502 Aussie Membrane 502

2-Part Heavy Duty Below Grade Bituminous Waterproofing Membrane

ICC ESR-2503
L.A. RR#: 25550

Sections 071000 / 071400 / 071416
Fluid Applied Waterproofing

Product Name

Aussie Membrane 502
AVM System 502

Manufactured by

AVM Industries, Inc.
8245 Remmet Ave, Canoga Park, CA 91304
888.414.1041 818.888.0050
www.avmindustries.com

Product Description

The AVM Aussie Membrane 502 is a 2-part Water-Based rubber/bitumen liquid membrane modified with high performance rubberized polymers giving it excellent adhesion, which dries to a tough, black seamless flexible waterproof membrane. The Aussie Membrane 502 is a cold-applied liquid bitumen that exhibits excellent elongation and recovery properties. The AVM Aussie Membrane 502 has excellent long-term stability (maintains its properties of very long periods of time) un-like other below grade systems (including polyurethane based systems) that Crack and become brittle as they age.

Where to Use

Retaining Walls: Waterproof below-grade, concrete, block walls, basements, etc.

Planters: Waterproof planters and other landscaping features.

In-between slab waterproofing: To provide a sandwich membrane in-between two concrete slabs or over wood decks that will receive a topping slab. Also used as an under-tile membrane when a mud-bed or thick-set type assembly is required.

Green Roofs (Roof Gardens): For waterproofing roofs and other areas that will be turned into gardens or areas that support vegetation, plants, trees, etc. (Complete system includes membrane, root barrier, drainage mat, drains, light weight soil, etc.)

Roof Paver System: For waterproofing of roofs (including over living space) and other areas in which a paver system will be installed. (Such as pavers over pedestals).

Warranty

Basic Warranty: Five (5) years. Longer warranties are also available. (Up to 20 years on some systems/applications) For complete warranty options and details, contact AVM Industries or consult with your applicator.



Delivery, Storage, and Handling

- Delivery of all the AVM System 502 materials to the job site must be in their original sealed containers, with manufacturer's name and label intact.
- Handle and store containers in accordance with printed instructions.
- Store at temperatures between 50°F and 90°F. Do not store materials in direct sunlight or where they may be damaged by water or rain.
- Failure to comply with the recommended storage conditions may result in premature deterioration of the product. For specific storage advice, please contact AVM Industries and/or its representatives.
- Keep all materials out of the reach of children.
- If irritation occurs during use, liberally flush affected areas with water. If irritation continues, see a physician immediately.

Project Conditions

- All surfaces to which the Aussie Membrane 502 is applied to must be sound and stable, with an even finish and free from dust, loose debris, grease, curing agents, etc. (for under-slab, lagging, etc, see under separate cover)
- The Aussie Membrane 502 may be applied to damp but not waterlogged surfaces (Green Concrete)
- Apply materials in temperatures of 40°F and rising. (applications in temperatures below 40°F require special procedures) Do not apply materials if precipitation is imminent or in direct sunlight at temperatures above 100°F or rising. For applications at temperatures below 40°F, contact AVM for cold weather installation procedures.
- Warn personnel against hazards of materials to skin and eyes. Note other hazardous conditions on the job that might require special protective gear and or any other special protective or safety procedures.
- Protect adjacent surfaces which could be damaged during the application procedure.
- This system must not be used to cover Expansion Joints.

System Application

Read the AVM System 502 Installation Instructions Prior to Installation. Application instructions vary based on type of application and the type of surfaces it's being applied to. For specific application procedures, refer to, or download the appropriate installation instructions. (For Retaining Walls, refer to the "Retaining Walls Installation Instructions". For a Lagging System, refer to the "Lagging System Installation Instructions". Etc.)

Basic installation procedures are also provided in the "Spec Data Sheet" of each type of installation. For a complete/comprehensive set of instructions, however, please refer to the "Installation Instructions" documents.

Quality Control

- Visually inspect all coated surfaces to ensure a full and proper coating application, especially at corners, drainage footings and other hard-to-reach areas.
- All unsatisfactory areas shall be repaired prior to final acceptance.

Protection of Installed Work

- The completed section shall be protected for the first 24 hours after application or until the surface is sufficiently cured. (The amount of drying time may vary depending on temperature and humidity conditions)
- Always protect the waterproofing from possible damage. Use AVM Foam Board, AVM Drainage Boards or AVM Approved Protective Panels. Refer to the "spec Data Sheets" or to the "Aussie II Min Thickness Table" for protection details.

Availability and Cost

Contact AVM Industries or your approved applicator for pricing and availability.

Technical Services

Technical services are available by contacting our offices at: **888.414.1041** or **818.888.0050** or visit **www.avmindustries.com**

System Specifications

See next page.

The following coverages are based on controlled tests. Actual coverages may vary.

Technical Information		
Color	Emulsion: Dark brown. Membrane: black	
Specific Gravity	1 gr/cm ²	
Solid Content	60% +/- 2%	
Flash Point	Non-flammable	
Service Temperature	15°F-140°F (-10°C to +60°C)	
Application Temperature	40°F-100°F (+5°C to 40°C)	
Heat Stability	>194°F (>90°C)	ASTM D 2939
Cold Flexibility	-4°F (-20°C)	ASTM D 522
Low Temperature Flexibility and Crack Bridging	Pass, Conducted @ -15°F (-26°C)	ASTM D 836
Tensile Strength	>0.1 MPa (>14.2 psi)	ASTM D 412
Elongation at break	>1200%	ASTM D 412
Resistance to water pressure	>1 atm, 24 hr (>14.7 psi, 24 hr)	DIN 52123
Water vapor permeance	0.35 Perms	ASTM E 96
Recovery (at 800-900% elongation)	>85%	ASTM D 412
Creep At 212°F (100°C)	No Creep	DIN 52123
Resistance to Standing Water	Passed	ASTM D 2939
Bacterial Attack in soil 30 days @ 105°F (40°C)	Passed	ASTM D 3083
VOC (Volatile Organic Content)	20 Grams/Liter	
Crack bridging	>3/16" (>5mm)	IS 1731
Approvals / Certifications	ICC, LARR, ISO 9002, Green Label, I.Q. Net (International Certification Network)	

Mixing / Spraying Information	
Mixing Ratio	Accelerator (Salt water): Pour the 55 lbs of salt into 32-35 gallons of water
Spraying Ratio	1 Gallon accelerator (salt water) to 9 gallons of bitumen

For membrane thickness and drainage board requirements refer to the "Aussie II Min Thickness Table"

Coverage Tables (for U.S. and Metric Measurements)								
To Get	60 Mils Dry	90 Mils Dry	100 Mils Dry	120 Mils Dry	160 Mils Dry	180 Mils Dry	240 Mils Dry	270 Mils Dry
Apply	100 Mils Wet	150 Mils Wet	160 Mils Wet	200 Mils Wet	160 Mils Wet	300 Mils Wet	400 Mils Wet	450 Mils Wet
For 100 sqft	5.75 Gallons	8.75 Gallons	9.5 Gallons	11.5 Gallons	15 Gallons	17.25 Gallons	23 Gallons	26.25 Gallons
To Get	1.5 mm Dry	2.25 mm Dry	2.5 mm Dry	3.0 mm Dry	4.0 mm Dry	4.5 mm Dry	6.0 mm Dry	6.75 mm Dry
Apply	2.4 mm Wet	3.6 mm Wet	4.0 mm Wet	4.8 mm Wet	6.4 mm Wet	7.2 mm Wet	9.6 mm Wet	10.8 mm Wet
For M ²	2.4 kg/m ²	3.6 kg/m ²	4.0 kg/m ²	4.8 kg/m ²	6.5 kg/m ²	7.3 kg/m ²	9.6 kg/m ²	10.8 kg/m ²

Item / Component	Packaging	Approx Shipping Weights	VOC
AVM Primer 500	2.0/5.0 gal. pails	2.0/5.0 gal. 15/39 lbs.	15 Grams/Liter
AVM Aussie Membrane 502	264 Gal Totes	264.0 gal. 2,200 lbs / 1,000 kg (1-Ton)	19 Grams/Liter

Retaining Wall with Aussie Membrane

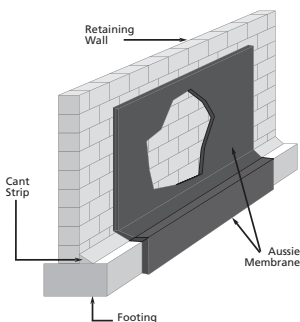

In-Between Slab Waterproofing

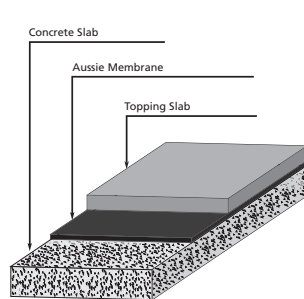

Block Walls with Aussie Membrane

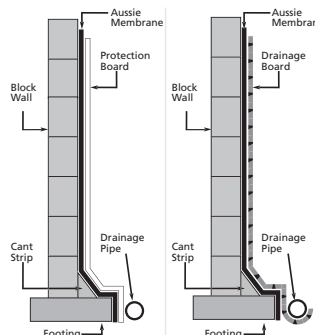

Planter with Aussie Membrane

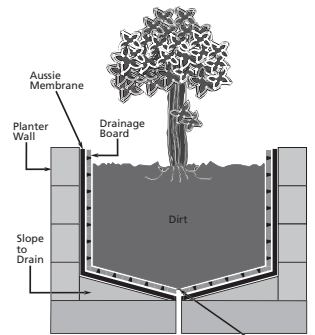

For a complete list of details in CAD or PDF, please visit our website at www.avmindustries.com.

AVM Industries, Inc.
8245 Remmet Ave, Canoga Park, CA 91304
888.414.1041 818.888.0050

Quality Waterproofing Products



www.avmindustries.com