



FIG 1 – AUSSIE SKIN 560G INSTALLED ON BLINDSIDE WALL

## AVM System – Aussie Skin 560G

### DESCRIPTION

Aussie Skin 560G is an extra heavy duty pre-applied 2.0 mm sheet waterproofing, methane, & shotcrete approved membrane. It is comprised of a thick HDPE layer with advanced weather resistant dual factory laps, two release liners, a low reflectivity exposed surface, two non-factory lap options and additional technologies creating

excellent adhesion between the membrane and wet concrete or shotcrete. Once the concrete or shotcrete is fully cured, the membrane will become fully bonded to the concrete surfaces eliminating any potential migration of water between itself and the concrete surface in which it is bonded to.

Product	Packaging	Approximate Shipping Weight	Qty Per Pallet	VOC
Aussie Skin 560G Membrane 2M (100 Mills)	6.56'x65.6' Roll (430 sqft)	211 lbs (96 kg)/roll	18 rolls/pallet	N/A

### APPLICATIONS

Aussie Skin 560G is excellent for waterproofing below-grade horizontal and vertical surfaces. Applications include underslab and property line walls, including soldier pile and lagging, metal sheet piling, and shotcrete soil retention.

### APPROVALS

Aussie Skin 560G is an approved methane barrier through the Los Angeles Research Report (LARR). Carrying the LARR approval, as well as being approved for shotcrete applications, makes the Aussie Skin 560G a perfect waterproofing membrane and methane barrier in both hydrostatic and non-hydrostatic conditions.

### DELIVERY, STORAGE, HANDLING

Delivery of Aussie Skin 560G products to the jobsite must be in their original containers. Long term storage (over a week) of products should be indoors at temperatures between 50-90°. On the jobsite, if products will be exposed to the weather, AVM strongly recommends covering with a tarp or other protection. Failure to comply to recommended storage conditions may affect product performance and/or void the warranty.

### ACCESSORY PRODUCTS

**Aussie Skin Detail Strip 560G:** 13" wide Aussie Skin 560G detail membrane without sand used for detailing penetrations, corners, and overlaps.

**Aussie Skin Sanded Tape:** 4 in. wide accessory tape, with sand adhered to one side, and pressure sensitive adhesive on the back side. Used to tape corners, edges, penetrations, and un-sanded exposed areas.

**Aussie Skin Dual-sided Tape:** 4 in. wide double-sided stick tape. Double Sided Tape may be applied on both horizontal and vertical Aussie Skin waterproofing applications and is also used in detailing the Aussie Skin waterproofing system in corners, edges, penetrations.

**Aussie Swell Red Waterstop:** Active swelling concrete joint waterstop used around penetrations and applicable concrete joints.

**Aussie Sealant M:** Marine grade single component polyether sealant/adhesive. Used to adhere Aussie Swell Red Waterstop, around penetrations, and at terminations.

**Aussie Clay 590:** Waterproofing membrane composed of granule bentonite needle-punched between a woven & non-woven geotextile. Used in conjunction with Aussie Skin 560G in hydrostatic shotcrete applications.

**AVM Drain Board 6000:** Drainage composite composed of a molded core profile core & a filter fabric. Used to remove hydrostatic presence in non-hydrostatic conditions. Can also improve substrate conditions.

**AVM Bottom Drain:** Thickened base drain composite designed to collect water from sheet drainage pales and then discharge water through collector pipes to collection system.

**Aussie Tube:** ½ in. wide permeable tube installed prior to concrete placement, with packers set at 25 ft. on center. Inject after concrete cure. Provide min. 2½ in. concrete cover on all sides. Stagger end laps of hose min. 2 in. Used in trouble areas and in cold joints as a waterstop.

**Termination Bar:** Extruded-aluminum or formed-stainless-steel bars with upper flange to receive sealant. Used to terminate membrane at grade or during transitions.

**Spray Adhesive:** Super 77 by 3M or approved equal. Environmentally friendly, spray adhesive for drainage panel filter fabric lap joints.

**Staples:** Galvanized staples approved by membrane manufacturer. Staples for securing vertical waterproofing panels to wood lagging prior to concrete placement.

**Tie Back Cover:** 4", 6", & 8" heavy duty plastic used to cover tie-backs during concrete placement.

### LIMITATIONS

Aussie Skin 560G should only be installed after proper substrate preparation has been completed and is appropriate to receive waterproofing. Use Aussie Skin 560G with reinforced shotcrete walls or cast-in-place walls, conforming to ACI 506 Core Grade 1 or 2; minimum 8" thick. For shotcrete applications in hydrostatic conditions, Aussie clay 590 will need to be installed in conjunction with the Aussie Skin 560G. Do not use stay-in-place concrete forming, use removable forming products only. Aussie Skin 560G is designed for pre-applied applications. Do not use Aussie Skin 560G in any application where new concrete is not directly placed against the membrane, such as post applied backfill wall conditions.

**Formwork Removal:** In areas where formwork is to be removed (slab edges, footings, top of wall) for tie-into post-applied waterproofing, the formwork shall remain in place for a minimum 72 hours after placement of concrete. Please contact AVM if form removal is scheduled sooner as this could affect the Aussie Skin's bond to the concrete.

# SECTION 1 – UNDERSLAB INSTALLATION

Aussie Skin 560G is engineered for use under reinforced foundation concrete slabs. Aussie Skin 560G cannot be used when protection slabs are placed over the membrane prior to the foundation slab. Aussie Skin 560G can be installed over an unreinforced mud slab or compacted earth/gravel. Complete all required elevator pit, sump pit, grade beam and piling work prior to installing the Aussie Skin 560G over the main slab area. All areas should be tied into the underslab waterproofing to create proper continuous installation forming a monolithic barrier throughout the underslab.

## 1.1 – Substrate

Prior to installing the Aussie Skin 560G, the substrate must be prepared to meet the installation requirements. Aussie Skin 560G can be placed on compacted earth/crushed stone or a prepared non-reinforced mud slab.

Earth or Crushed Stone: Earth/sand substrates should be compacted to a minimum of 85% Modified Proctor Density. The substrate must be free of loose aggregate and sharp protrusions. Avoid curved or rounded substrates. Ensure substrate is well compacted to avoid displacement of substrate due to traffic or concrete placement. Grout around all penetrations such as utility conduits, etc. for stability.

Unreinforced Concrete Rat Slab: Provide uniform, broom finished concrete substrate. Infill voids, honeycombs and gaps greater than 1/2 in. deep with grout. Grind down all projections, ridges, and sharp fins greater than 1/4 in.

## 1.2 – INSTALLATION: General

Install the Aussie Skin 560G over the prepared substrate with the HDPE fil side to the substrate and the granulated surface facing up. Stagger end laps a minimum of 12" to avoid a build-up of layers. Accurately position succeeding sheets to overlap the previous sheet along the selvedge. Ensure the underside of the succeeding sheet is clean, dry and free from contamination before attempting to overlap. Gently wipe with a rag if there is dirt or debris on the underside. Peel back the plastic release liner from between the overlaps as the two layers are bonded together. Ensure a continuous bond is achieved without creases and roll firmly with a heavy roller. See **Figure 1.1** for standard overlap spacing.

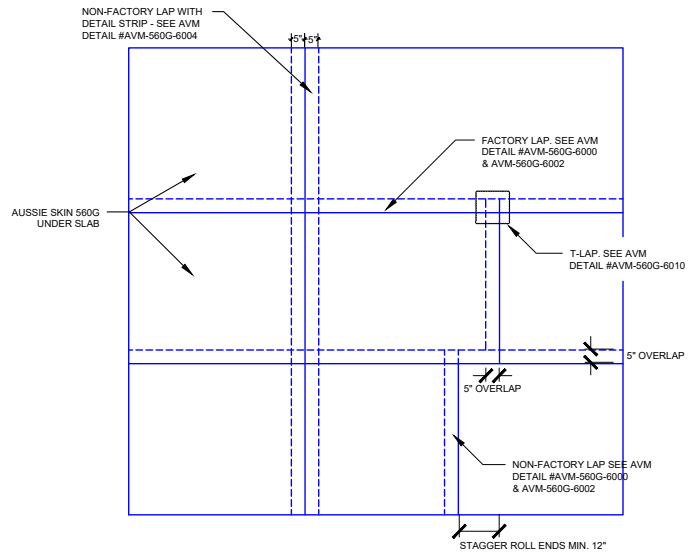
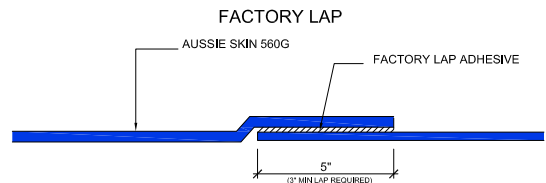

FIGURE 1.1 – STANDARD OVERLAP SPACING

Whenever the slab is placed in sections, the membrane should be extended a minimum of 12" beyond the slab placement to ensure that a proper tie in can be completed when tying into new material. These 12" tail sections should be protected from foot traffic and damage. **Figures 1.2 & 1.3** will show the single selvedge edges. **Figures 1.4 & 1.5** will show the Dual Salvage Edges.



Important Note: When installing the "Factory Lap", The Installation procedure should be as follows:  
 1) Remove the black plastic film from the factory lap to expose the adhesive.  
 2) Lay down the 2nd layer of Skin over the exposed Adhesive. (leave 1/8"-1/4" of adhesive exposed) Roll the steel roller over the 2nd layer of skin several times while applying significant pressure.  
 3) Verify seam is completely and properly bonded.

FIGURE 1.2 – SINGLE SALVAGE EDGE FACTORY LAP

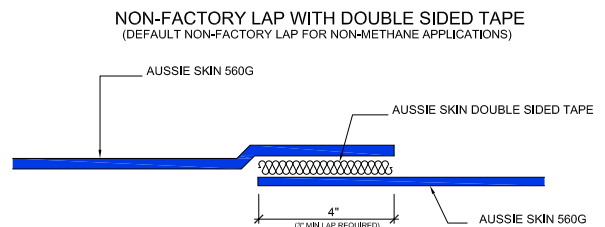

Important Note: When installing the "Non-Factory Lap", The Installation procedure should be as follows:  
 1) Remove the black plastic film from one side of the double-sided tape.  
 2) Lay down the Double-Sided Tape on the sanded side of the first layer of Aussie Skin.  
 3) THOROUGHLY COMPRESS THE DOUBLE-SIDED TAPE ONTO THE SANDED SIDE OF THE AUSSIE SKIN USING AVM'S APPROVED STEEL ROLLERS. (ROLL THE STEEL ROLLER OVER THE TAPE SEVERAL TIMES WHILE APPLYING SIGNIFICANT PRESSURE)  
 4) Carefully remove the clear film (2nd layer of film) from the Double-Sided Tape.  
 5) Lay down the 2nd layer of Skin over the exposed double-Sided Tape. (Leave 1/8"-1/4" of tape exposed) Roll the steel roller over the 2nd layer of skin several times while applying significant pressure.  
 6) Verify seam is completely and properly bonded.  
 7) If multiple pieces of Double-Sided Tape are needed, overlap them.

FIGURE 1.3 – SINGLE SALVAGE EDGE NON-FACTORY LAP

# Installation Instructions

## FACTORY LAP - DUAL SALVAGE EDGE

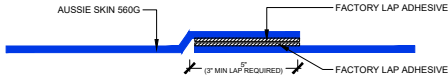

Important Note: When installing the "Factory Lap", The Installation procedure should be as follows:  
 1) Remove the black plastic film from the factory lap on the bottom sheet to expose the adhesive.  
 2) Remove the black plastic film from the factory lap on the top sheet and lay down onto 1st layer of Skin over the exposed Adhesive. (Leave 1/8" - 1/4" of adhesive exposed) Roll the steel roller over the 2nd layer of skin several times while applying significant pressure.  
 3) Verify seam is completely and properly bonded.

FIGURE 1.4 - DUAL SALVAGE EDGE FACTORY LAP

## NON-FACTORY LAP

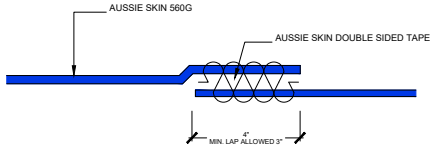

Important Note: When installing the "Non-Factory Lap", The Installation procedure should be as follows:  
 1) Remove the black plastic film from one side of the double-sided tape.  
 2) Lay down the Double-Sided Tape on the sanded side of the first layer of Aussie Skin.  
 3) THOROUGHLY COMPRESS THE DOUBLE-SIDED TAPE ONTO THE SANDED SIDE OF THE AUSSIE SKIN USING AVM'S APPROVED STEEL ROLLERS. (ROLL THE STEEL ROLLER OVER THE TAPE SEVERAL TIMES WHILE APPLYING SIGNIFICANT PRESSURE)  
 4) Carefully remove the clear film (2nd layer of film) from the Double-Sided Tape.  
 5) Lay down the 2nd layer of Skin over the exposed double-Sided Tape. (Leave 1/8" - 1/4" of tape exposed) Roll the steel roller over the 2nd layer of skin several times while applying significant pressure.  
 6) Verify seam is completely and properly bonded.  
 7) If multiple pieces of Double-Sided Tape are needed, overlap them!

FIGURE 1.5 - DUAL SALVAGE EDGE NON-FACTORY LAP

There are situations when it is needed to use the detail strip to connect two sections of the Aussie Skin 560G. The 13.1" strip has the adhesive backing on the HDPE allowing the strip to overlap a minimum of 5" on each of the Aussie Skin sheets. This is shown in **Figure 1.6**

## NON-FACTORY LAP WITH DETAIL STRIP (DEFAULT NON-FACTORY LAP FOR METHANE APPLICATIONS)

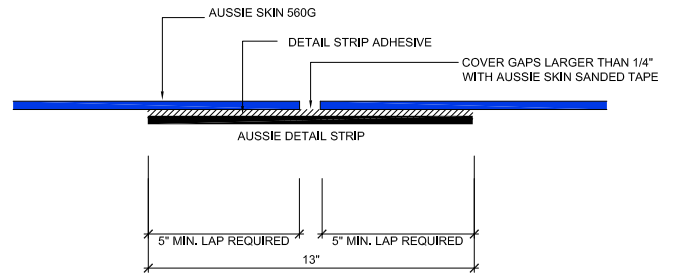

FIGURE 1.6 - NON-FACTORY LAP WITH DETAIL STRIP

There may be instances where it is required to lap onto two separate membrane sheets. This is referred to as a T-Lap, as the three corresponding sheets that are over lapping will form a T. **Figure 1.7** will show the sequencing on how to accomplish this.

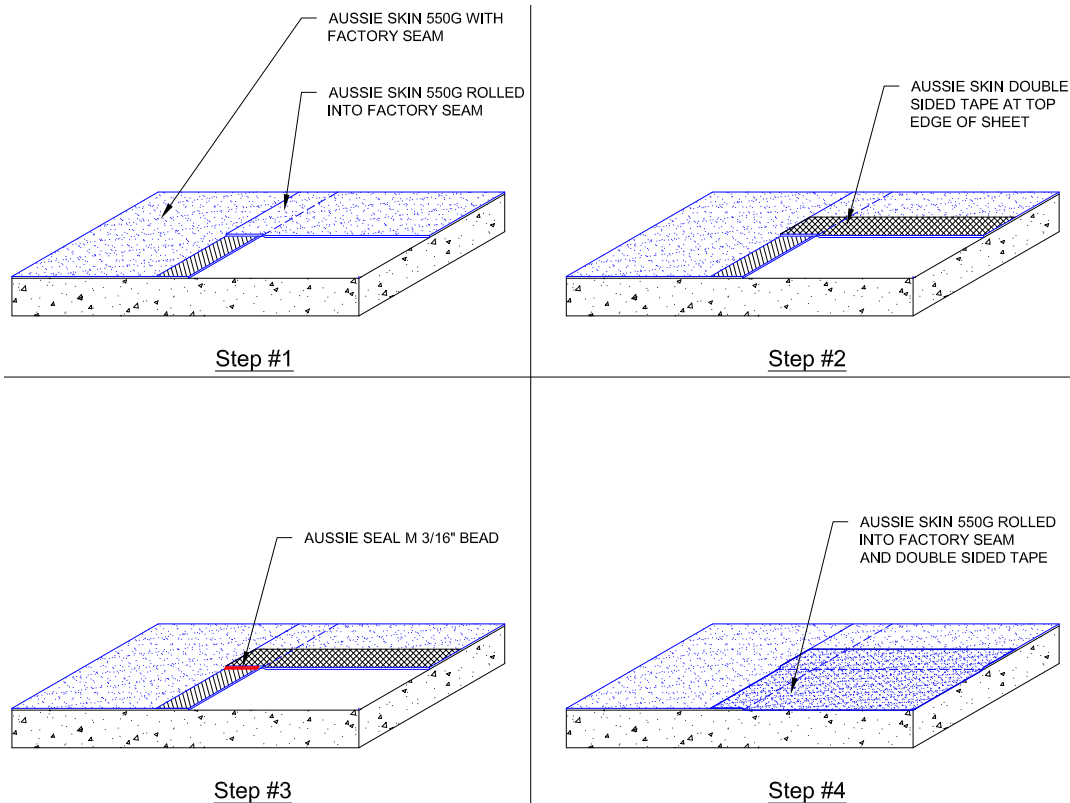

FIGURE 1.7 - SEQUENCING OF THE T-LAP

## 1.3 - INSTALLATION: Raised Slabs, Slab on Grade, and Wrapped Footings

Tying underslab waterproofing to vertical waterproofing is necessary in hydrostatic conditions in order to create a bathtub around the building preventing that hydrostatic pressure from entering the building, Aussie Skin 560G can only be installed in conditions with fresh concrete placement so it needs to tie into another membrane whenever there is a post applied application up the vertical wall. Aussie Swell Red Waterstop should be placed at the wall/slab joint. An Aussie Swell Red Waterstop Red should also be placed at the wall/slab on grade joint if applicable. **Figure 1.8** shows the Aussie Skin 560G wrapped under the footing and tying into AVM's Aussie Mate 580-AL.

Note: Formwork should not be removed until a minimum 72 hours after concrete placement

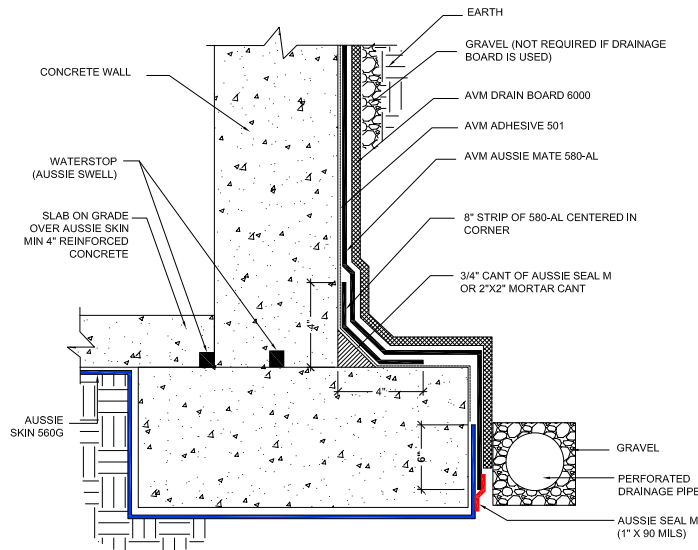

FIGURE 1.8 - 560G UNDER SLAB TYING INTO AUSSIE MATE 580-AL

## 1.4 - INSTALLATION: Pipe Penetrations

For slab pipe penetrations, cut the Aussie Skin 560G to fit as close around the penetration as possible. Place Aussie Seal M around the pipe penetration extending 2" around the penetration to fill any void between the Aussie Skin 560G and the penetration and 2" up the penetration with a 3/4" fillet at the base. An Aussie Swell Red Waterstop will be placed around the pipe penetration with a minimum of 3" of concrete coverage. See **Figure 1.9**.

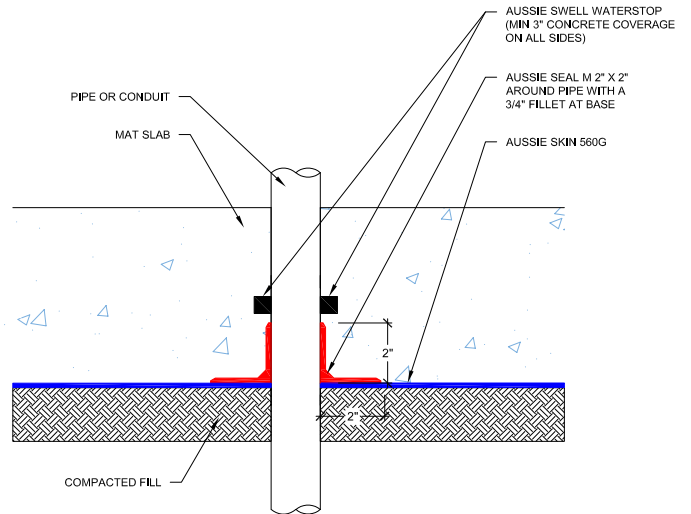

FIGURE 1.9 - PIPE PENETRATION THROUGH SLAB

With multiple pipe penetrations, ensure there is 6" between each pipe and install the same as above. When the 6" cannot be achieved like in pipe bank applications, a pitch pan would be required. In this scenario, cut the membrane so it is butted against the outside penetrations as closely as possible. Create a metal pitch pan out of sheet metal and place it around the cluster of pipes. Install AVM System 520 into the pitch pan at a minimum of 2" thick. Lap Aussie Skin Sanded Tape from the Aussie Skin membrane over the pitch pan to create a continuous granule surface. See **Figure 1.10** for reference.

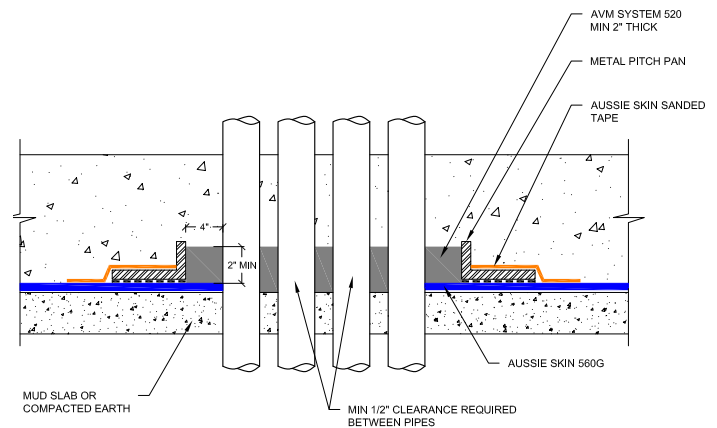

FIGURE 1.10 - PITCH PAN PIPE BANK DETAIL

1.5- INSTALLATION: Grade Beams & Pile Caps

Installation of grade beams and pile caps are dependent on whether the condition is hydrostatic or non-hydrostatic. In hydrostatic conditions, it is important to keep the waterproofing continuous to prevent intrusion of water.

For non-hydrostatic conditions, the Aussie Skin 560G will be installed 4" minimum onto the pile cap or grade beam and terminated. Aussie Seal M will then be placed on the 4" of Aussie Skin 560G that extends onto the grade beam/pile cap and extend an additional 4" onto the grade beam/pile cap. This will be shown on Figure 1.11.

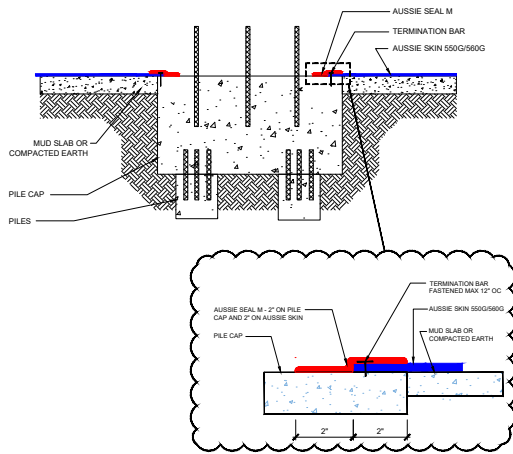

FIGURE 1.11 - NON-HYDROSTATIC PILE CAP DETAIL

For hydrostatic conditions, the detailing will be different as to ensure there is not a break in the waterproofing. One way to do this is to install the Aussie Skin underneath the grade beam as shown on Figure 1.12.

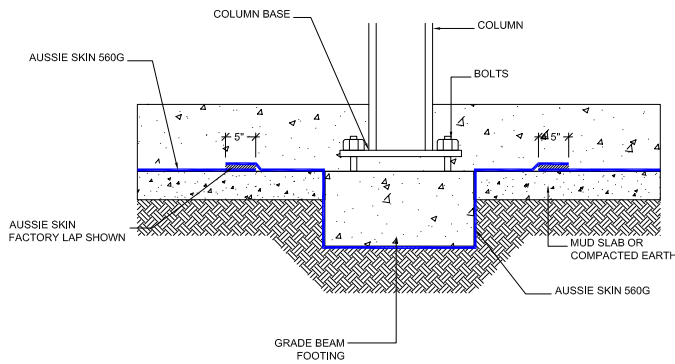

FIGURE 1.12 - WRAPPED GRADE BEAM

When this is not possible, Aussie Skin 560G will terminate similarly as the non-hydrostatic detail. However, the grade beams and pile caps can be covered with the fluid applied polyurethane AVM System 520 which will tie into the Aussie Skin 560G to ensure the waterproofing is continuous. The tie-in between the 520 System and

the 560G Aussie Skin for a grade beam is shown in Figure 1.13 on the next page. Figure 1.14 will show the tie in with a pile cap. Note the use of silica sand with the AVM System 520, this is up to the design team.

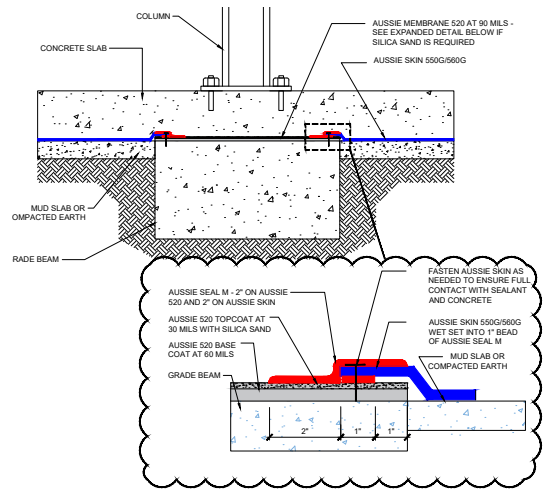

FIGURE 1.13 - HYDROSTATIC GRADE BEAM DETAIL

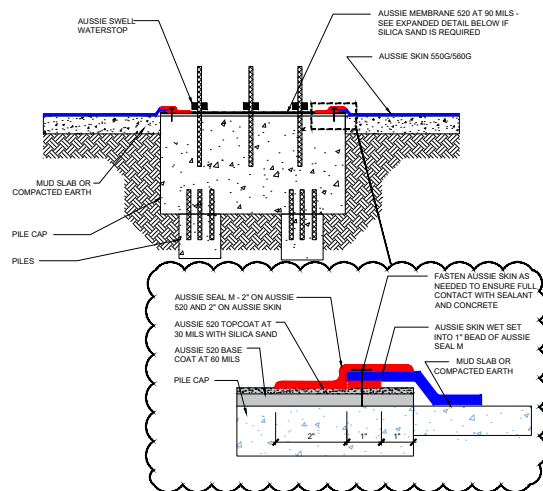

FIGURE 1.14 - HYDROSTATIC PILE CAP WITH AUSSIE SKIN 560G

1.6 - INSTALLATION: Elevator Pits

Aussie Skin 560G will should be placed on vertical surfaces and on the substrate under slab to provide a continuous envelope around the elevator pit. Ensure the soil cut is smooth and soil to provide a proper substrate for the Aussie Skin 560G to be installed over. For unstable soil conditions, it is recommended to install a retaining wall to contain the soil. Extend the membrane a minimum of 12" onto the horizontal surface when you bring up the pit wall. Overlap it 5" onto the underslab membrane that it is tying into. Please refer to Figure 1.15 for this installation.

# Installation Instructions

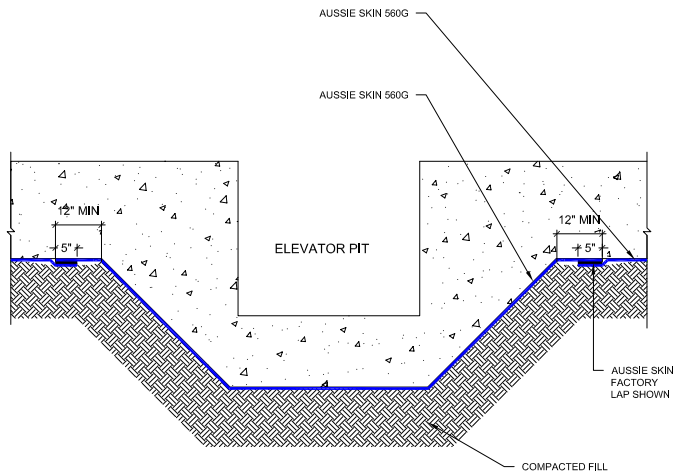

FIGURE 1.15 - ELEVATOR PIT

## 1.7 - INSTALLATION: Edge of Slabs, Transition to Propertyline

When transitioning from underslab to a propertyline application, such as wood pile and lagging (Figure 1.16), sheet metal piling, and shotcrete retaining walls, extend the vertical base course sheet a minimum of 12" onto the underslab. The granule side of the membrane should be facing the installer for both the horizontal and vertical installation. Form the membrane tightly into the corner. Try to avoid excessive wrinkling of the membrane. Hang the membrane that runs vertically up the shoring wall by fastening the outer edge of the factory seam so there is a minimum of 2" of exposed adhesive toward the inside of the membrane to provide for proper lap adhesion. When the shoring wall is composed of metal sheet piling, fasten plywood over the sheet metal piling and fill all voids with compacted soil or concrete to give the membrane a proper substrate as shown in Figure 1.17.

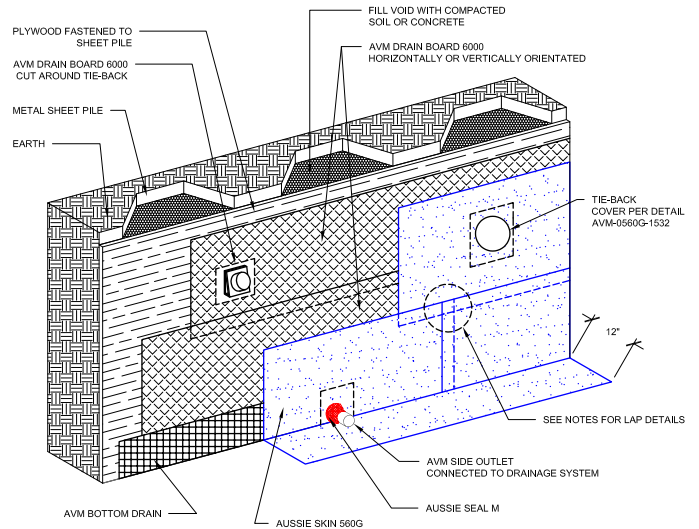

FIGURE 1.17 - SHEET METAL PILING

Inside and outside corners are completed in steps to ensure that the proper overlaps and continuity is administered throughout the installation. Figure 1.18 will depict the steps to complete a proper inside corner detail while Figure 1.19 will provide the instructions for a proper outside corner at the bottom of a wall.

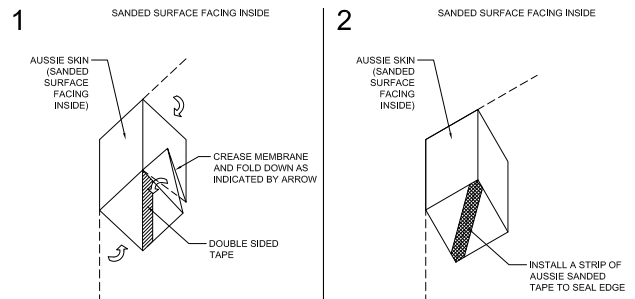

FIGURE 1.18 - INSIDE CORNER

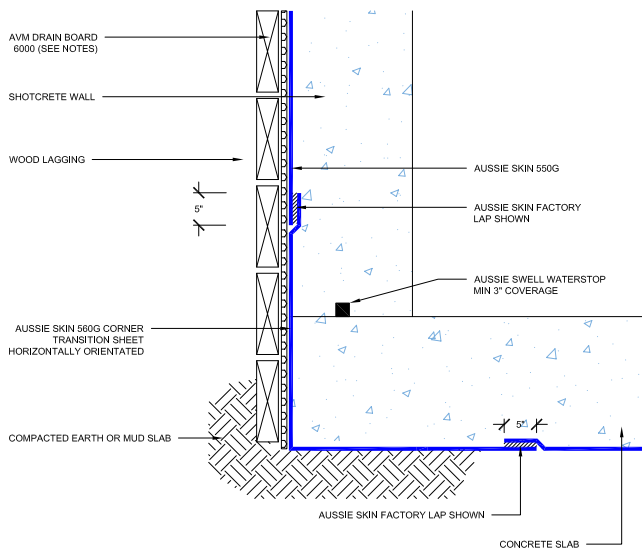

FIGURE 1.16 - UNDERSLAB TO PROPERTYLINE TRANSITION

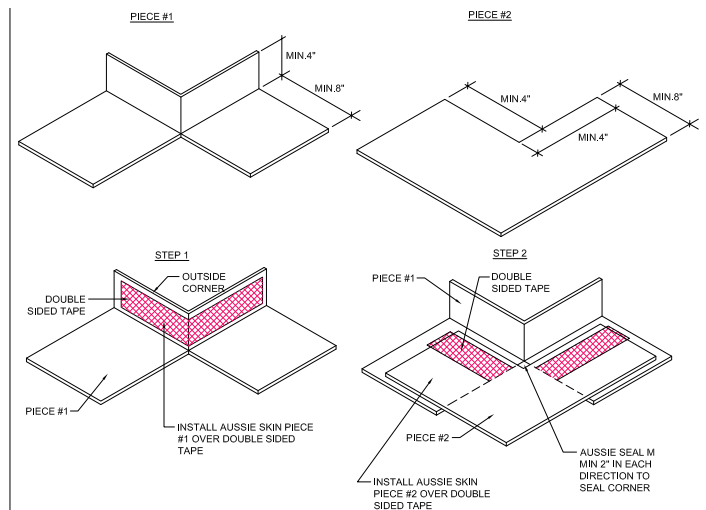

FIGURE 1.19 - OUTSIDE CORNER

## SECTION 2 - PROPERTYLINE INSTALLATION

Aussie Skin 560G is designed to be installed in blindside or propertyline conditions making it an excellent choice in both cast in place or shotcrete applications for both hydrostatic and non-hydrostatic conditions. Hydrostatic shotcrete conditions will vary installation guidelines. Aussie Skin 560G can be installed over wood pile and lagging, sheet metal piling or shotcrete retaining walls. When installing the Aussie Skin 560G in propertyline conditions, always ensure the HDPE liner is facing the shoring while the granule side is facing the installer. For non-hydrostatic conditions, it is recommended that the AVM 6000 Drain Board is used to collect water and carry it into a drainage system.

### 2.1 - SUBSTRATE:

Prior to installing the Aussie Skin 560G, the substrate must be prepared to meet the installation requirements. Penetrations should already be in place to ensure proper detailing at the time of installation.

**Sheet Piling:** Use concrete, plywood, board insulation, or drainage panel or other approved facing over sheet piling to provide support to the membrane.

**Wood Lagging Shoring:** Extend to the lowest level of the waterproofing installation with any voids or cavities exterior of the lagging timbers filled with compacted soil or cementitious grout. Interior surface of lagging boards should be planar and tight together with gaps less than 1/2 in. Gaps in excess of 1/2 in. should be filled with cementitious grout, compacted soil, wood, extruded polystyrene (20 psi minimum) or AVM approved polyurethane spray foam. If insulation protection board or drainage panel is utilized over the lagging, the allowable gaps may be up to 2 in. wide.

### 2.2 - INSTALLATION: General

Once the slab to wall corner transition has been installed, the membrane can be installed in either a vertical or horizontal fashion up the remaining wall. While installing the Aussie Skin 560G up the wall, power actuated fasteners or staples will need to be used to help hold the membrane in place until it is time to receive the concrete placement. AVM recommends the use of 1" metal washer head fasteners when hanging the membrane. Fasteners should be installed towards the outer edge of the factory seam so that there is a minimum 2" of exposed adhesive toward the inside of the membrane, to allow for proper lap adhesion. Typical distance between fasteners is approximately every 24"- 36" on center. Depending on substrate and length of fastener, additional fasteners may be required to hold membrane in place, particularly when using the 2-meter-wide rolls. When using fasteners in locations away from the outer edge and more centered in the membrane, patching the fasteners is required. The style of patching is dependent on whether the membrane is in the water table or not and if the fastener is flush to the membrane. The below Figures will show these conditions.

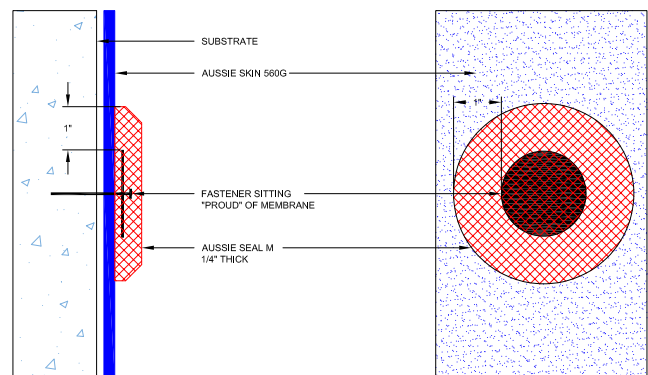

FIGURE 2.1 - NON-FLUSH FASTENER DETAIL



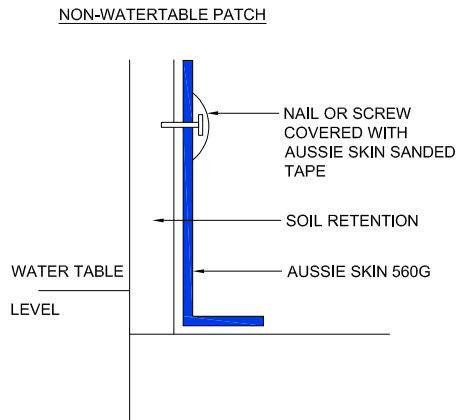

FIGURE 2.2 - NON-WATER TABLE PATCH

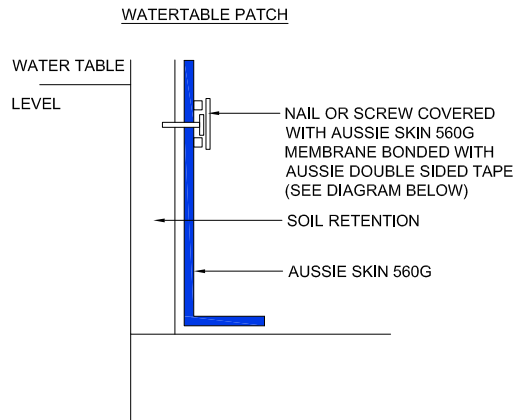

FIGURE 2.3 - WATER TABLE PATCH

**Below Water Table Installations:** All nails, screws, etc., used to hang the Aussie Skin below the water table must be non-rusting and sealed with a 3"x3" patch of Aussie Skin 560G bonded with Aussie Tape.

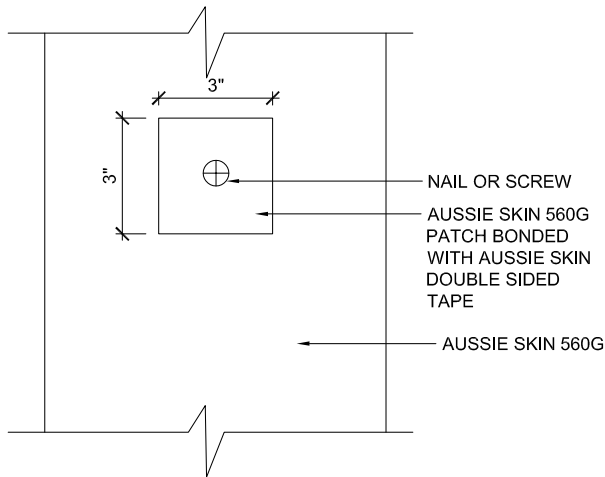

FIGURE 2.4 - PATCHING AUSSIE SKIN 560G

### 2.3 - INSTALLATION: Pipe Penetrations

Much like the detailing done for underslab conditions, pipe penetrations for propertyline applications begin by cutting the Aussie Skin 560G to fit as close around the penetration as possible. Place Aussie Seal M around the pipe penetration extending 2" around the penetration to fill any void between the Aussie Skin 560G and the penetration and 2" up the penetration with a 3/4" fillet at the base. An Aussie Swell Red Waterstop will be placed around the pipe penetration with a minimum of 3" of concrete coverage. Shown on **Figure 2.5** on the following page. When there are sleeved pipe penetrations, concrete work will need to include filling the gap between the pipe and the sleeve with a non-shrink cementitious grout, mechanical seal by others and then an Aussie Swell Red waterstop on the outside of the sleeve. See **Figure 2.6** for detail. For multiple pipe penetrations, detail like a singular but ensure there is a minimum of 6" between each penetration. For other pipe penetrations, refer to the AVM Technical Team for an approved detail.

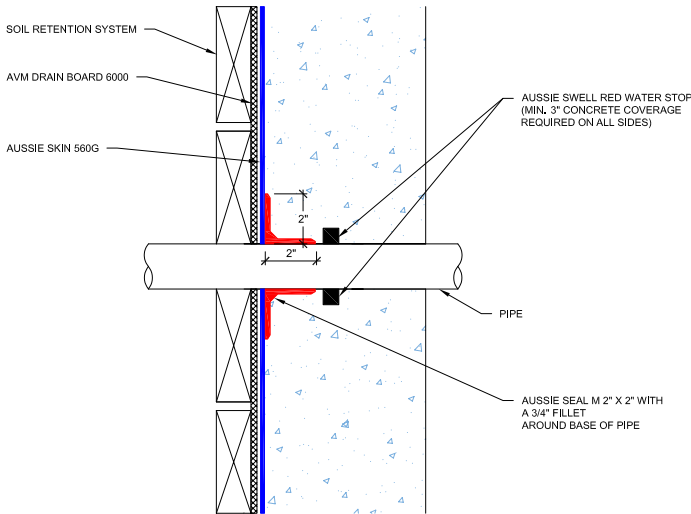

FIGURE 2.5 - PIPE PENETRATION THROUGH WALL

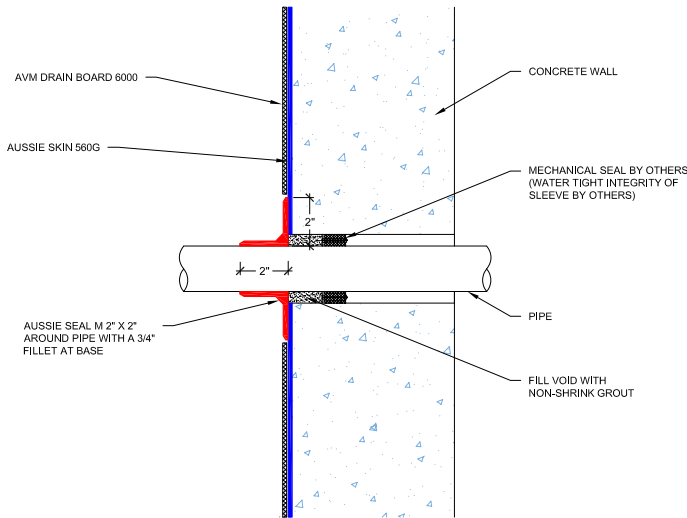

FIGURE 2.6 - CORED PIPE PENETRATION

## 2.4 - INSTALLATION: Tie-Backs

Tie-backs can be waterproofed a few different ways with the Aussie Skin 560G: using an AVM Tie-Back Cover (recommended) and boxing out and detensioning the tie-back. If neither of these methods can be achieved, refer to the AVM Technical Team. When using an AVM Tie-Back cover, select the proper sized Tie-Back Cover (4", 6", 8") to fit over the tie-back and allow proper concrete coverage per project requirements. Once the Tie-Back Cover is over the tie-back, place a 4" strip of Aussie Skin Double-Sided Tape on the flaps of the Tie-Back Cover. Run the Aussie Skin 560G over the other edge of the Aussie Skin Double-Sided Tape so it is adhered and place a 3/4" cant of Aussie Seal M to seal the edges of the Aussie Skin 560G against the Tie Back Cover. This is shown on **Figure 2.7**.

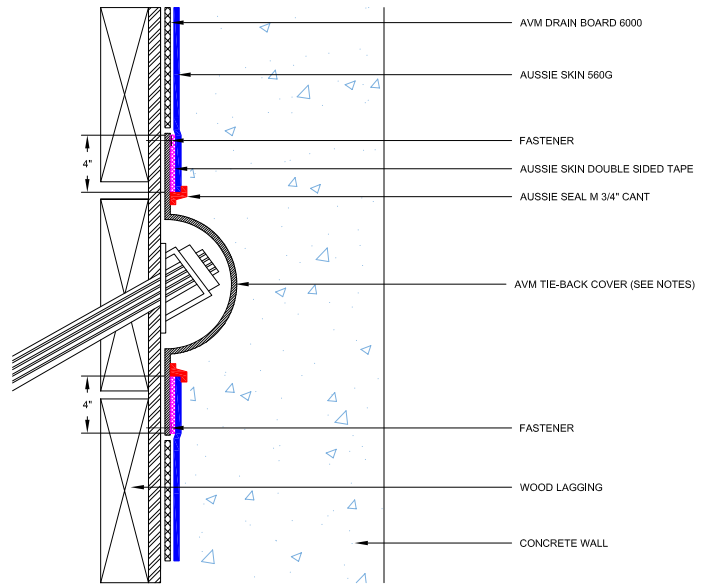

FIGURE 2.7 - TIE BACK COVER DETAIL

Detensioning the tie-back by the way of boxing it out is another common way to waterproof tie-backs. With this approach, install the Aussie Skin tightly up to the tie-back. Forms or a sonotube will be placed around the tie-back to box it out during the concrete placement. Once the placement is completed, the tie-back will then be detensioned. From there, smooth any edges with Aussie Seal M. A patch of Aussie Skin 560G will be placed over the area where the tie-back was detensioned extending 4" past the perimeter. Aussie Skin Double-Sided Tape will need to be used to adhere the patch. An Aussie Swell Red will be placed around the perimeter of the box-out before the box-out is filled with non-shrink grout or concrete. **Figure 2.8** shows this.

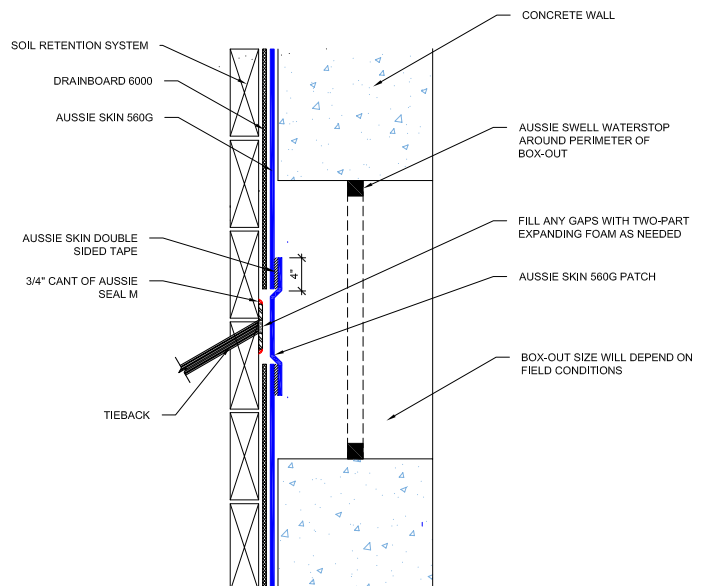

FIGURE 2.8 - DE-TENSIONING OF TIE BACK W/ BOX OUT

2.4 - INSTALLATION: Lagging Board Removal at Grade & Grade Termination

Prior to installing Aussie Skin 560G to finished grade, install a ½” thick cementitious wall board centered over steel soldier pile from finished grade elevation to the specified depth that the top of the wood lagging and soldier pile will be removed. This will protect the membrane from getting burned or damaged during removal. **Figure 2.9** on the next page will show this. Any areas damaged during removal of the soldier pile and lagging will need to be repaired. The Aussie Skin 560G can then terminate or tie into an above grade membrane. **Figure 2.10** shows typical grade termination.

\*Note: Formwork should not be removed until a minimum 72 hours after concrete placement.

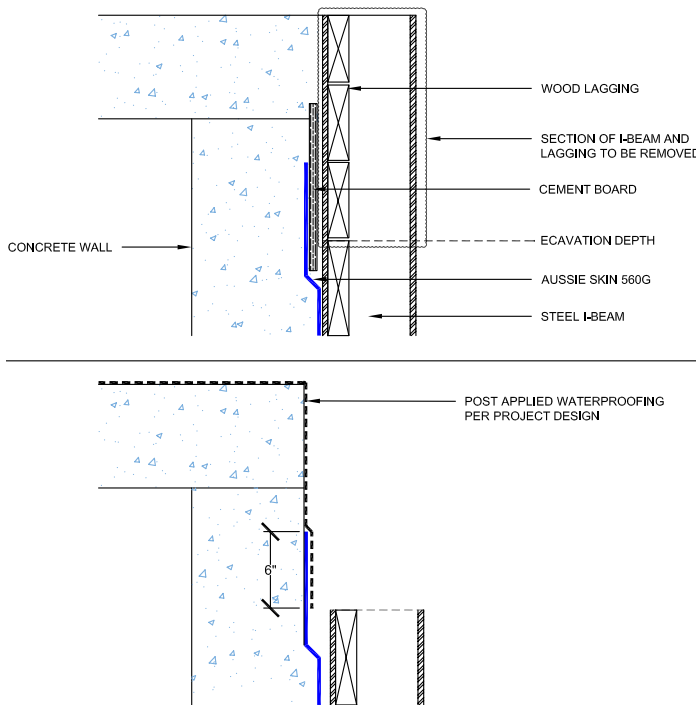

FIGURE 2.9 - CEMENT BOARD AT GRADE

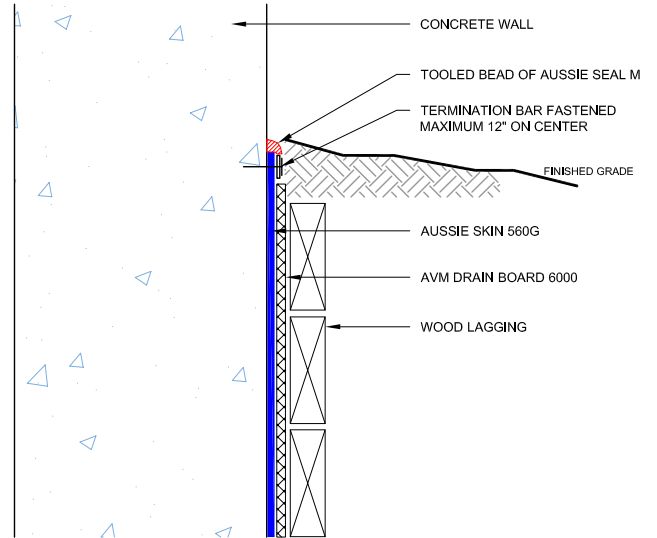

FIGURE 2.10 - GRADE TERMINATION

## SECTION 3 – HYDROSTATIC SHOTCRETE (DUAL LAYER SYSTEM)

Shotcrete, or concrete being projected onto a surface at high velocity pneumatically, is becoming a more popular option when placing concrete because it does not require forms. While it reduces the time to place concrete, there are some challenges when it comes to shotcrete. Voids in the concrete and cracks forming due to shrinkage can be common issues with shotcrete applications. These issues can be problematic to the waterproofing, particularly when hydrostatic conditions exist. A more robust system is required to overcome these problems to ensure a watertight building. This robust system consists of a dual layer system, those layers being the Aussie Skin 560GG and the Aussie Clay 590. This section will include the installation instructions for the Dual Layer system for Hydrostatic Shotcrete conditions.

**\*NOTE: For non-hydrostatic conditions, installation will follow the instructions under Section 2 in this manual unless otherwise stated by the design team. Dual Layer system is only required for hydrostatic conditions.**

### 3.1 – INSTALLATION: Wall top Slab Transition

When installing the dual layer system, it is important to sequence the membranes in the correct fashion. The Aussie Clay 590 (for information on all variations please see Aussie Clay 590 product manual) will always be installed over the shoring with the grey woven geotextile facing the installer. From there, the Aussie Skin 560G will be placed over the Aussie Clay 590 with the granule side facing the installer.

The dual layer system installation begins with the wall to slab transition. An Aussie Clay 590 transition sheet should first be placed at the corner of the underslab to vertical installation. This transition sheet should extend a minimum of 12" onto the underslab with the remaining sheet placed vertically up the shoring. The next Aussie Clay sheet should be placed on the shoring overlapping the transition sheet a minimum of 4". Installers should then take a sheet of Aussie Skin 560GG and fold it in half horizontally. The crease formed from the horizontal fold will be placed in the corner with half the sheet extending over the 12" min Aussie Clay 590 extension onto the underslab and the other half folder up the shoring over the placed Aussie Clay 590. The Aussie Skin sheet that extends onto the underslab will then be tied into the underslab waterproofing with the standard lap as described in Section 1.2. **Figures 3.1 & 3.2** will show these transitions.

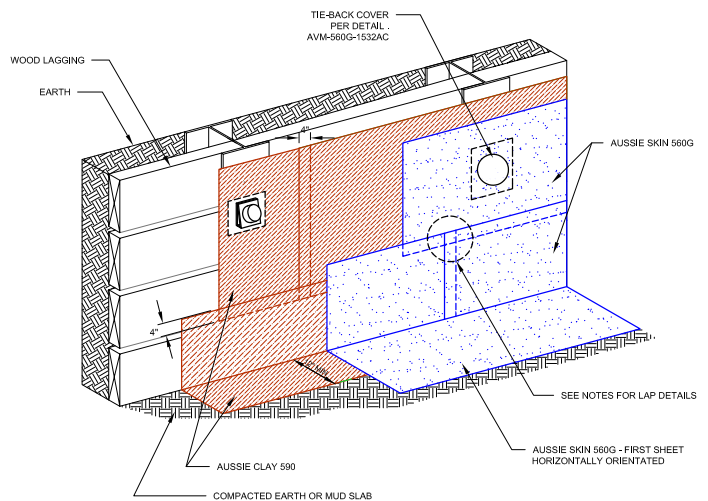
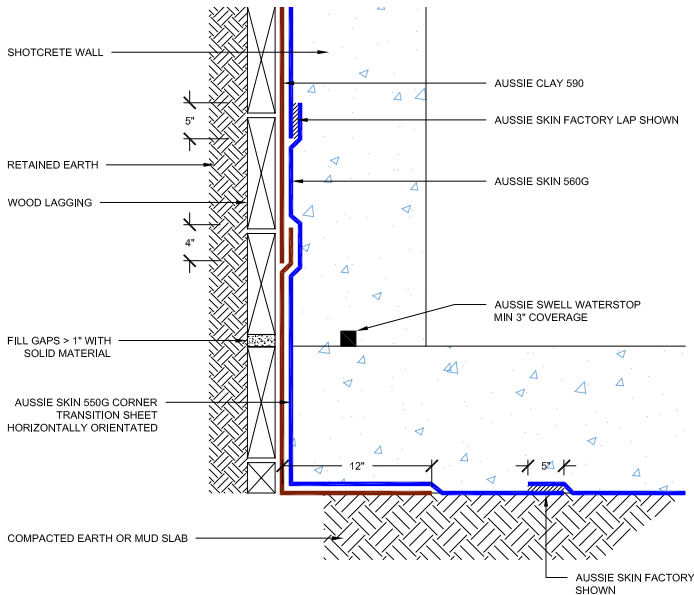
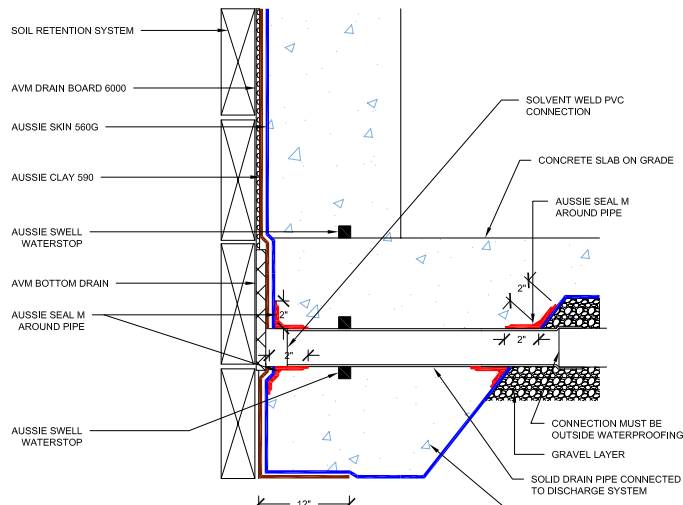

FIGURE 3.1 – DUAL LAYER UP LAGGING WALL

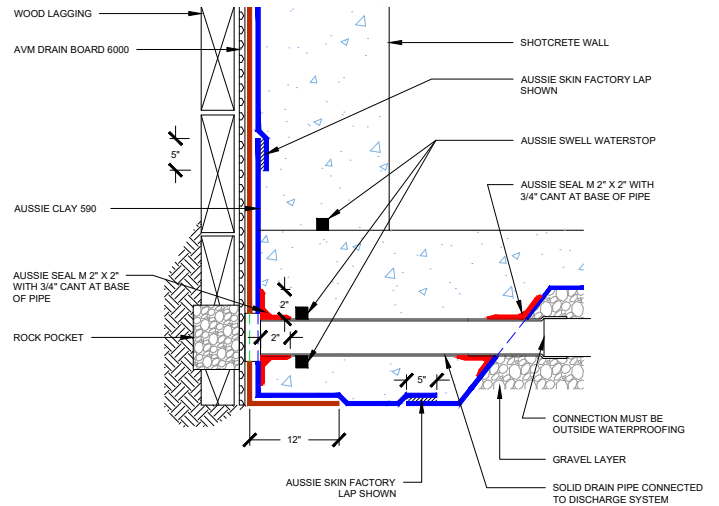

**FIGURE 3.2 - DUAL LAYER TIE-IN TO UNDERSLAB WITH 5" FACTORY LAP**

When the conditions call for a raised slab with a drainage system underneath the slab, the installation will be done very similarly as the above instructions. This is different if there is a non-hydrostatic condition and the design team still would like to utilize the robust dual layer system. See **Figure 3.3 & 3.4**.



**FIGURE 3.3 - NON-HYDROSTATIC RAISED SLAB**



**FIGURE 3.4 - ROCK POCKET DRAIN DETAIL**

### 3.1 - INSTALLATION: Pipe Penetrations

When detailing pipe penetrations, cut a hole in both the Aussie Clay 590 and Aussie Skin 560GG to fit as closely to the penetration as possible. Place Aussie Seal M around the pipe penetration extending 2" around the penetration to fill any void between the Aussie Skin 560G and the penetration and 2" up the penetration with a 3/4" fillet at the base. An Aussie Swell Red Waterstop will be placed around the pipe penetration with a minimum of 3" of concrete coverage. For sleeved pipes, the sleeve needs to be filled with a non-shrink grout and a mechanical seal will be placed by others. **Figure 3.5** will show a typical sleeved pipe penetration.

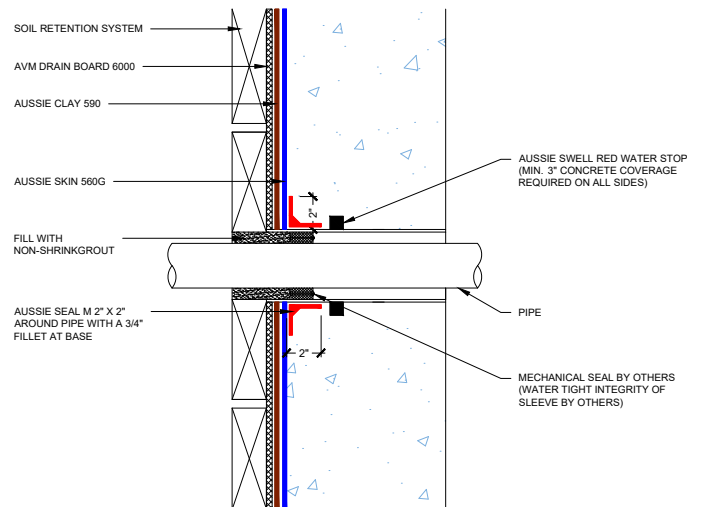

**FIGURE 3.5 - SLEEVED PIPE PENETRATION**

Rebar ties are going to be done in a very similar fashion as the pipe penetrations, but the Aussie Seal M will only extend 1" around the pipe penetration to fill the voids between the Aussie Skin 560G and 1" up the rebar tie. Aussie Swell Reds will be placed around the rebar tie. Use a zip tie or tie wire to hold the Aussie Swell around the rebar tie. **Figure 3.6** shows this.

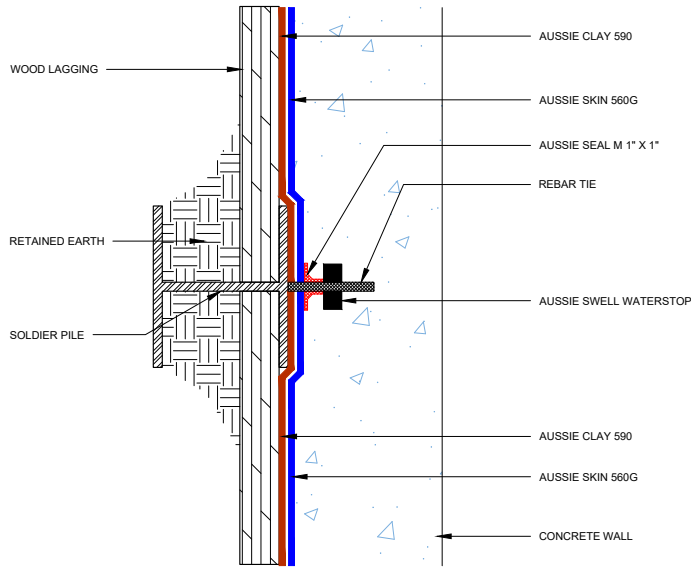

FIGURE 3.6 - DUAL LAYER REBAR TIE

### 3.3 - INSTALLATION: Tie-backs, Rakers, & Soldier Piles

As discussed in section 2.4, tie-backs can be done a few different ways: with the AVM Tie-Back Cover and by boxing-out/detensioning the tie-back. When using the AVM Tie-Back Cover, run the Aussie Clay 590 up tight against the tie-back. Place the cover over the tie-back and fasten through the Tie-Back Cover base through the Aussie Clay 590. The rest of the installation will follow the same guidelines as the installation in section 2.4. This is shown in **Figure 3.7**. When boxing the tie-back out and detensioning the tie-back, start by running the Aussie clay 590 up tight against the tie-back. Install the Aussie Skin 560GG over the Aussie Clay 590 but come 4" short of the Aussie Clay 590. Once concrete is placed and the tie-back is detensioned, come over the edges of the tie-back with Aussie Clay Sealant to soften the edges. An Aussie Clay 590 patch will be placed over the Aussie Clay Sealant with the edges overlapping the Aussie Clay 590 field sheet. An Aussie Skin 560GG patch is then placed over the Aussie Clay 590 patch with the Aussie Skin 560GG patch overlapping the Aussie Skin 560GG field sheet 4". Aussie injection tubes should be placed around the perimeter of the box-out

as well as an Aussie Swell Waterstop prior to the box-out being filled with a cementitious non-shrink grout or concrete. **Figure 3.8** shows this detail.

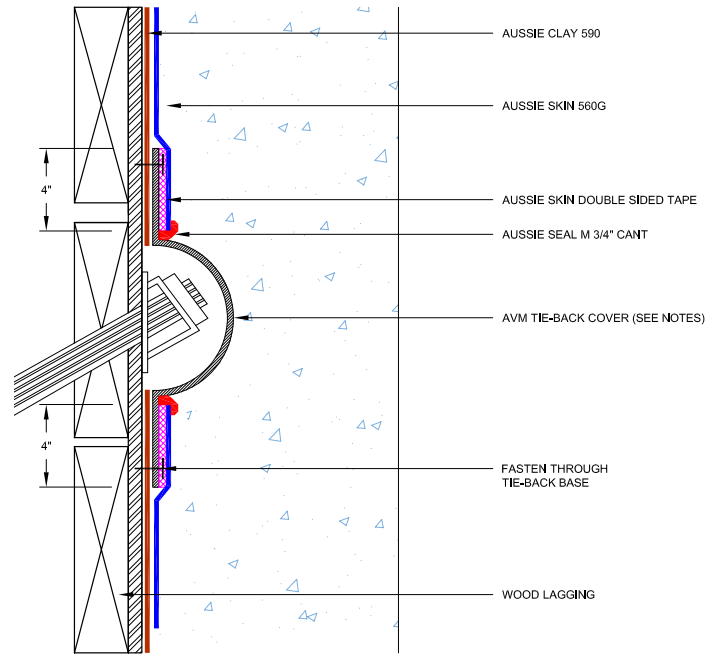

FIGURE 3.7 - DUAL LAYER SYSTEM W/ TIE BACK COVER

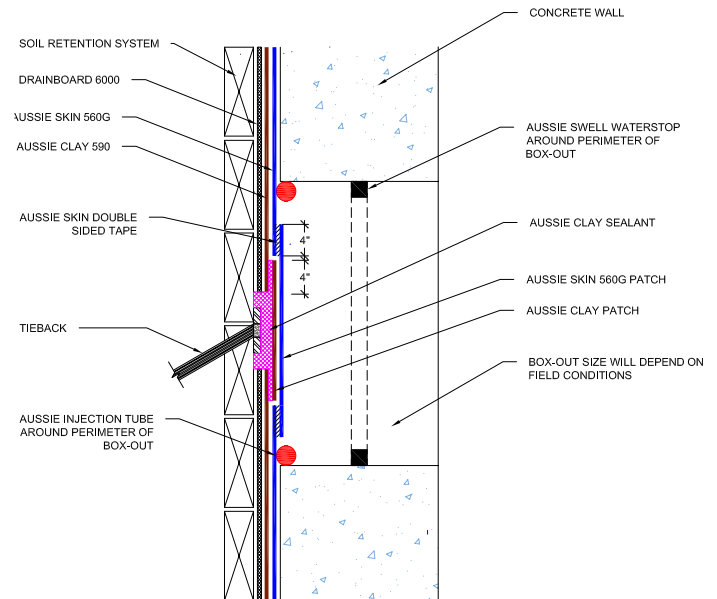

FIGURE 3.8 - DE-TENSION TIE-BACK WITH BOX-OUT

## Installation Instructions

With back-lagged soldier piles, take the Aussie Clay 590 and run it to the soldier pile. Leave 4" between the pile and the Aussie Clay 590. Take the Aussie Skin 560GG field sheet and run it over the Aussie Clay 590 and as tight up against the soldier pile as possible. Use Aussie-Skin Double-Sided Tape to adhere the Aussie Skin 560GG to the Soldier Pile. Install a 2"x2" fillet of Aussie Seal M at the base of the soldier pile. Continue the 2"x2" fillet of the Aussie Seal M around the base of the pile at the underslab. Finally, install an Aussie Swell Red up the edge of the soldier pile. This is shown in **Figure 3.9**.

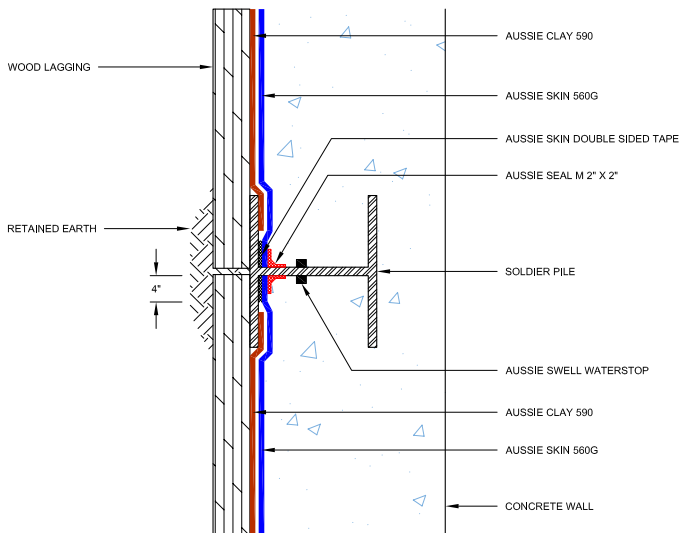

FIGURE 3.9 - DUAL LAYER BACK LAGGED SOLDIER PILE

### 3.3 - INSTALLATION: Lagging Board Removal at Grade & Grade Termination

Because of the bond that is formed from concrete being directly placed onto the Aussie Skin, terminations will need to be done after concrete placement and the bond between the Aussie Skin and the concrete has sufficiently formed. Like in a single layer system, the termination can be done with by stopping the membrane at grade or in the form of a transition to an above grade membrane. Unlike the single system grade termination detail which requires the counter flashing over the membrane at grade, the dual layer system can be terminated with a termination bar installed at the top edge of the membranes every 12" on center with a tooled bead of Aussie Seal M over the term bar. The Aussie Clay 590 will be facing the installer when working post applied. **Figure 3.10 & 3.11** shows the termination detail.

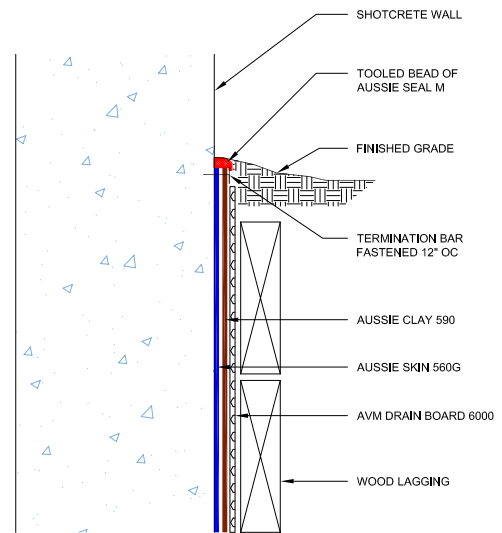

FIGURE 3.10 - GRADE TERMINATION OPTION 1

Much like in the single layer system, when lagging removal is to be done, a cement board will need to be placed between the Aussie Clay 590 membrane and the lagging board to prevent damage from occurring when the boards and soldier pile are removed. Once the pile and lagging are removed to the excavation depth, the cement board can be removed as well as the Aussie Clay 590 that extends past the excavation depth. A min of 6" of Aussie Skin 550G will need to be left over to tie into any post applied waterproofing per the project design, **Figure 3.12** will show the 2-step process of removing lagging at grade with the dual system.

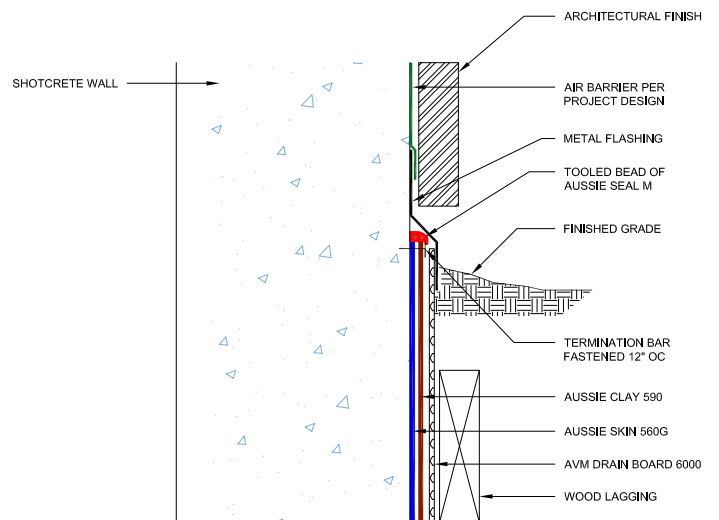

FIGURE 3.11 - GRADE TERMINATION OPTION 2

## SECTION 4 – GAS VENTILATION

Aussie Skin 560G is an LARR approved methane and vapor barrier as well as being a robust waterproofing membrane that bonds with the concrete eliminating water migration. Because of the versatility and the double function of the membrane, it makes planning projects that require both waterproofing and vapor barriers very convenient. As shown in Section one of the product manual, the membrane is perfect for underslab installation. In that section, it entails the details and installation guidelines you would follow to install the membrane properly. This section will discuss AVM's gas ventilation system and how it would work with the Aussie Skin 560G.

**AVM Aussie DV:** The AVM Aussie DV is an accessory product that is specifically used for gas ventilation. It is a modular gas collection system consisting of a 3-D, high-flow, venting core which is wrapped with a non-woven filter fabric. It also includes special connectors for use in conjunction with active/passive gas venting system. It is installed directly on the sub-grade eliminating trenching. It has a larger opening area per linear foot compared to pipe allowing for higher ventilation efficiency. It is also placed closer to the vapor barrier for more effective venting. The Vent layout in the foundation slab is shown below in **Figure 4.1**. Spacing can vary depending on project specific design and contamination levels.

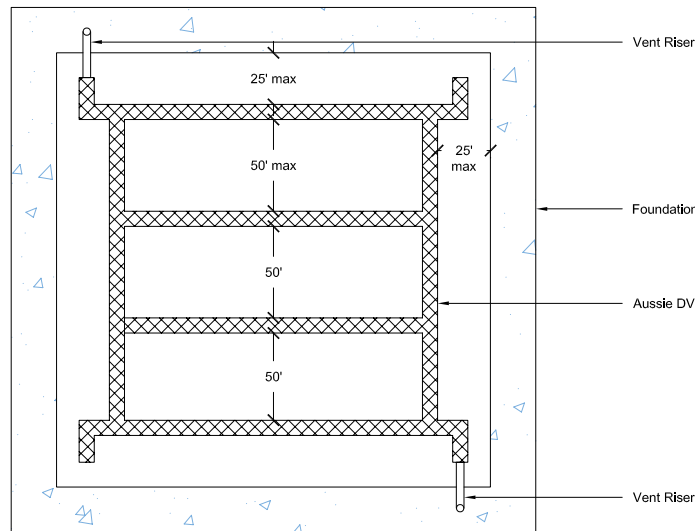

FIGURE 4.1 – AUSSIE DV VENT LAYOUT – PLAN VIEW

As the Aussie DV is positioned below the slab, the Aussie Skin 560 would be installed underslab as well. The Aussie DV is connected to vent riser PVC pipes that vent the vapor/gas. These PVC vent rising pipes will ultimately run through the membrane whether it is straight up through the slab or if the pipe runs through the wall. The pipes would be detailed just like standard pipe penetration details as described in Section 1 and shown below in **Figures 4.2 & 4.3**.

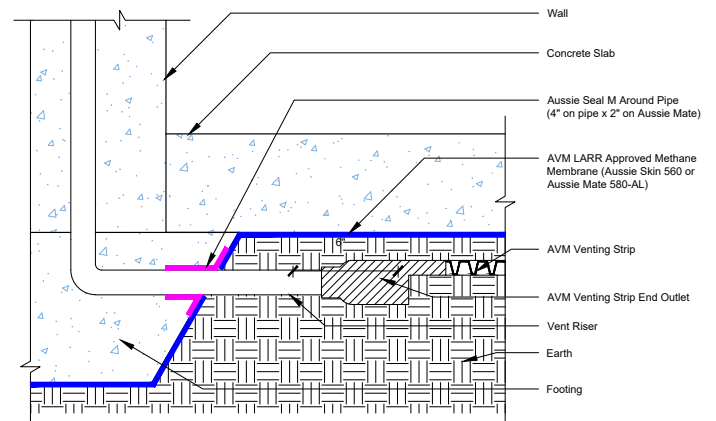

FIGURE 4.2 – GAS VENTILATION SYSTEM

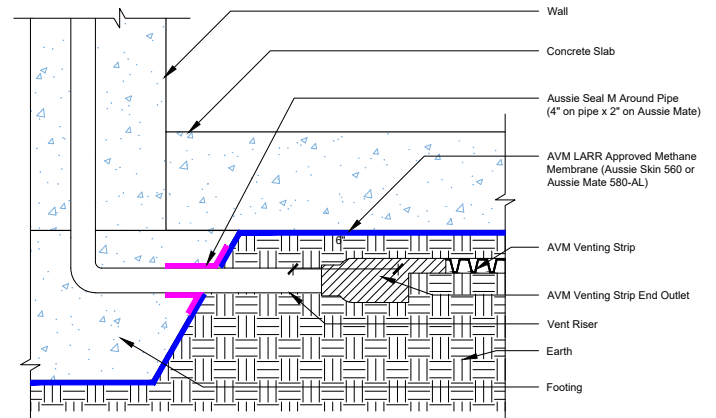

FIGURE 4.3 – VENT RISER STRAIGHT THROUGH SLAB



## Installation Instructions

To better understand the sequencing and the assembly of the ventilation system with the Aussie Skin 560G, please reference the below diagram **Figure 4.4**. The Aussie DV System is installed in the Drain Rock or Pea Gravel. The Aussie DV System ties into a vent riser either through the slab or through the wall to properly ventilate the vapor from below grade. The Aussie Skin 560G would then be installed over the gravel/rock with penetrations being detailed per Section 1. The slab would finally be poured over.

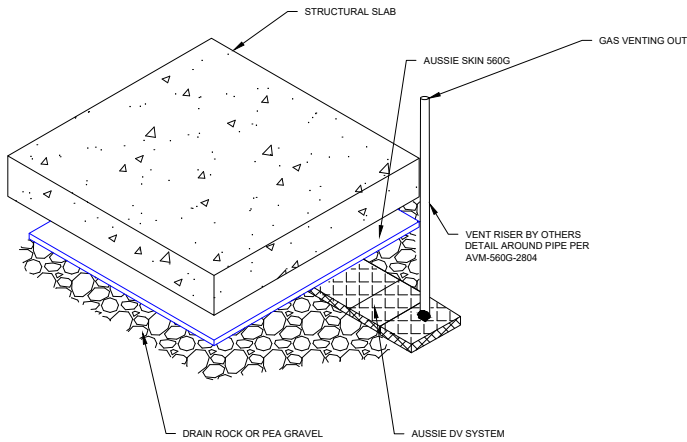
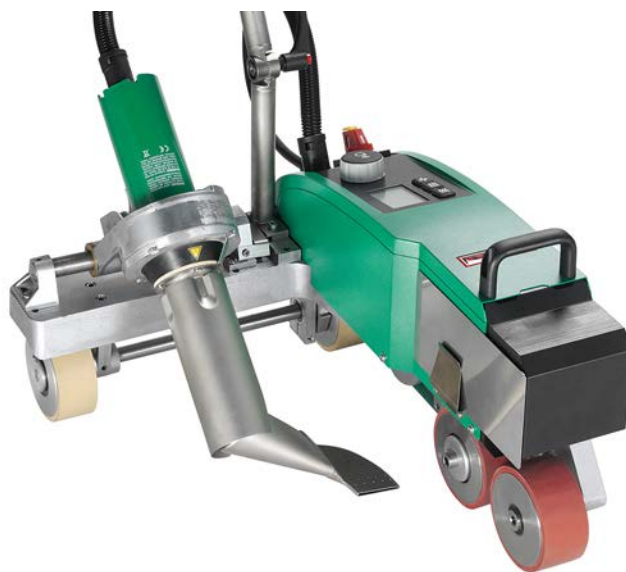

FIGURE 4.4 - 3-D DIAGRAM OF VAPOR MOVING THROUGH SLAB

## COLD WEATHER (20-40°) INSTALLATION

In colder temperatures, adhesives and sealants don't bond as well due to the temperatures causing reduced adhesion strength. During these conditions, additional procedures may be required to ensure proper bonding and performance.

1. Make sure to keep all Aussie skin accessories and sealant warm (approx. 70°F) A warm room or tent work well.
2. If feasible, store Aussie Skin rolls in heated areas as well.
3. Optionally can run a Leister heat welding machine (or a similar heat welding machine) over the seams as follows:
  - a. Use Leister Model Verimat 2 or a similar heat welding machine
  - b. Set Temperature to its lowest setting
  - c. Run the machine at a comfortable pace (optionally can run it at the top speed)
  - d. Check for proper adhesion once installed.
4. Detail Strips: Use the same cold weather installation procedures as factory and non-factory laps.
5. Applying double sided tapes to metal and metal I-Beams. Pre-heat the metal surfaces by lightly going over them with a heat gun or torch. Then immediately apply the double-sided tape to the metal surfaces and roll over the tapes with the steel pressure roller. Check for proper adhesion once installed.
6. Applying the sanded tapes – keep sanded tapes warm prior to use. Apply the sanded tapes and roll with pressure roller while still warm. If needed, use a heat gun to blow hot air over them while rolling the pressure roller over them to improve adhesion. Check for proper adhesion once installed.
7. Applying the fabric tapes - keep fabric tapes warm prior to use. Apply the fabric tapes and roll with pressure roller while still warm. If needed, use a heat gun to blow hot air over them while rolling the pressure roller over them to improve adhesion. Check for proper adhesion once installed.
8. Applying the sealant in cold weather (20°F - 50°F) keep the sealant warm prior to use. Apply the sealant while still warm. If needed, use at heat gun to blow hot air to pre-heat the substrates. Check for proper adhesion once installed. Sealant should be allowed to fully cure before exposed to hydrostatic pressures. In very cold weather this may take 14+ days. Therefore, make sure to keep dewatering systems active for a minimum 30 days after sealant installations.



LEISTER HEAT WELDER

## PROTECTING THE MEMBRANE

The membrane is often exposed to environmental and construction traffic, so it is important to protect the membrane during construction until the placement of concrete.

1. Use only water-based marking chalk on top of the installed waterproofing membrane. If other construction marking products are intended to be used, they must be reviewed and approved in writing by the waterproofing manufacturer.
2. Protect membrane during concrete placement from overspray with polyethylene sheeting or other approved means. Remove contamination and cured overspray material from membrane with mechanical means, taking extra care to not damage the waterproofing, prior to further placement of adjoining concrete.
3. Do not permit vehicular traffic on unprotected membrane.
4. Inspect for damage just prior to placement of concrete and make repairs in accordance with manufacturer's recommendations.
5. Product may not be exposed to sunlight for longer than 60 days. If exposure duration is approached and/or exceeded contact manufacturer representative for repair and/or replacement recommendations.

# PROTECTING THE MEMBRANE

The following coverages are based on controlled tests. Actual coverages may vary.

Item/Component	Packaging	Approximate Shipping Weights	Qty per Pallet	VOC
Aussie Skin 560G Membrane 2M (100 Mills)	6.56'x65.6' Roll (430 sqft)	211 lbs (96 kg) / Roll	18 Rolls/Pallet	N/A
Aussie Skin Detail Strip 560G	13.1"x65.6' Roll	30.8 lbs (14 kg) / Roll		N/A
Aussie Skin Double Sided Tape 4"	4"x33' Roll	2.2 lbs / Roll		N/A
Aussie Skin Sanded Tape 4"	3.9"x65.6' Roll	6 lbs / Roll		N/A

L021 Waterproofing Test Results	Test Results	Test Requirements	Test Method
Puncture Resistance	239 Lbf	Min 40 Lbs	ASTM E154
Hydrostatic Pressure Resistance	192 PSI	As Tested	ASTM D751
Lateral Water Migration Resistance	231 feet (71 M) of hydrostatic head pressure	Pass	ASTM D5385 Modified <sup>1</sup>
Resistance to Hydrostatic Head	231 feet (71 M) of hydrostatic head pressure	Pass	ASTM D5385
Adhesion to Concrete and Masonry	10 Pounds	Min 5 Pounds	ASTM D903
Tension & Elongation: Machine Direction	1061 %	Min 250%	ASTM D412
Tension & Elongation: Cross Machine Direction	1050 %	Min 250%	ASTM D412
Accelerated Aging	No considerable reduction in Tension and Elongation of Aged Specimens	Pass. No considerable reduction in either	ASTM G23 & G153
Resistance to Decay (Weight Loss)	0.8%	Max 10%	ASTM E154
Resistance to Decay (Permeance Loss)	0%	Max 10%	ASTM E154
Water Vapor Transmission	0.016 Perms	Max 0.1 Perms	ASTM E96
Water Vapor Transmission after Decay	0.016 Perms	Max 0.1 Perms	ASTM E96
Low temperature flexibility	Unaffected at -29°C	Not Listed	ASTM D1970
Shear strength of joints	14.5 (N/mm)	Not Listed	ASTM D1876
TCE Diffusion Coefficient	1.51E <sup>-12</sup>	Report Results	ASTM 96/96M-16
Benzene Diffusion Coefficient	1.45E <sup>-12</sup>	Report Results	ASTM 96/96M-16
Water Absorption	0.059%	As Tested	ASTM D570

1. Lateral water migration resistance is tested by casting concrete and shot-crete against membrane with a hole and subjecting the membrane to hydrostatic head pressure with water. The test measures the resistance of lateral water migration between the concrete and the membrane. Tests were performed by an independent certified lab. (This test is in addition to the L021 testing requirements)

VOC/Radon Test Results	Test Results	Test Requirements	Test Method
PCE Diffusion Coefficient	6.62E <sup>-13</sup>	Report Results	ASTM 96/96M-16
Radon Diffusion Coefficient D (m <sup>2</sup> /s)	2.2.10 <sup>-12</sup>	Report Results	ISO/TS 11665-13, Method A
Radon (Seam Overlap) Diffusion Coefficient D (m <sup>2</sup> /s)	1.6.10 <sup>-12</sup>	Report Results	ISO/TS 11665-13, Method A

Shot-Crete Test Results	Test Method	Results	Requirements
<b>Installation over Plywood or directly on the Lagging</b>			
Waterproof Integrity of Side (factory) Lap, overlap installed over 2" plywood joint with nails in laps	ASTM D 5385	Pass	No water leakage detected up to 100 PSI
Waterproof Integrity of End (non-factory) Lap, overlap installed over 2" plywood joint	ASTM D 5385	Pass	
Waterproof Integrity of Side (factory) Lap, overlap installed over 2" plywood joint without nails in laps	ASTM D 5385	Pass	No puncture detected
Puncture Integrity at Screw Protrusion, Membrane installed over 1/4" protruding #8 bugle head wood screw	Visual Inspection	Pass	
<b>Installation over Lagging 0.5" EPS Insulation Board (Foam)</b>			
Waterproof Integrity of Side (factory) Lap, overlap installed over EPS Foam Board located over 2" lagging joint with nails in laps	ASTM D 5385	Pass	No water leakage detected up to 100 PSI
Waterproof Integrity of End (non-factory) Lap, overlap installed over EPS Foam Board located over 2" lagging joint	ASTM D 5385	Pass	
Waterproof Integrity of Side (non-factory) Lap, overlap installed over EPS Foam Board located over 2" lagging joint; Joint without nails in laps	ASTM D 5385	Pass	No puncture detected
Puncture Integrity at Nail Protrusion Membrane installed over 1/4" protruding nail with 7/32" dia. head	Visual Inspection	Pass	
<b>Installation over Drain Board</b>			
Waterproof Integrity of Side (factory) Lap, overlap installed over Drain Board located over 2" lagging joint with nails in laps	ASTM D 5385	Pass	No water leakage detected up to 100 PSI
Waterproof Integrity of End (non-factory) Lap, overlap installed over Drain Board located over 2" lagging joint	ASTM D 5385	Pass	
Waterproof Integrity of Side (non-factory) Lap, overlap installed over Drain Board located over 2" lagging joint; Joint without nails in laps	ASTM D 5385	Pass	No puncture detected
Puncture Integrity at Nail Protrusion Membrane installed over 1/4" protruding nail with 7/32" dia. head	Visual Inspection	Pass	

Note: "Test Requirements" as listed in **Los Angeles City Test Protocol L021, Acceptance Criteria for Below-Grade Exterior Damp-Proofing and Waterproofing Materials dated May 2004 And Los Angeles City Shot-Crete Test Protocol dated April 26, 2016.**

\*AVM considers this product to be a VOC barrier based on the above test results. Please contact AVM Technical Services if you have further questions regarding specific VOC's

For a complete list of details in CAD or PDF, please visit our website at [www.avmindustries.com](http://www.avmindustries.com).



FIG 1 - AUSSIE SKIN 560G INSTALLED ON BLINDSIDE WALL

## AVM System – Aussie Skin 560G

### DESCRIPTION

Aussie Skin 560G is an extra heavy duty pre-applied 2.0 mm sheet waterproofing, methane, & shotcrete approved membrane. It is comprised of a thick HDPE layer with advanced weather resistant dual factory laps, two release liners, a low reflectivity exposed surface, two non-factory lap options and additional technologies creating

excellent adhesion between the membrane and wet concrete or shotcrete. Once the concrete or shotcrete is fully cured, the membrane will become fully bonded to the concrete surfaces eliminating any potential migration of water between itself and the concrete surface in which it is bonded to.

Product	Packaging	Approximate Shipping Weight	Qty Per Pallet	VOC
Aussie Skin 560G Membrane 2M (100 Mills)	6.56'x65.6' Roll (430 sqft)	211 lbs (96 kg)/roll	18 rolls/pallet	N/A

## APPLICATIONS

Aussie Skin 560G is excellent for waterproofing below-grade horizontal and vertical surfaces. Applications include underslab and property line walls, including soldier pile and lagging, metal sheet piling, and shotcrete soil retention.

## APPROVALS

Aussie Skin 560G is an approved methane barrier through the Los Angeles Research Report (LARR). Carrying the LARR approval, as well as being approved for shotcrete applications, makes the Aussie Skin 560G a perfect waterproofing membrane and methane barrier in both hydrostatic and non-hydrostatic conditions.

## DELIVERY, STORAGE, HANDLING

Delivery of Aussie Skin 560G products to the jobsite must be in their original containers. Long term storage (over a week) of products should be indoors at temperatures between 50-90°. On the jobsite, if products will be exposed to the weather, AVM strongly recommends covering with a tarp or other protection. Failure to comply to recommended storage conditions may affect product performance and/or void the warranty.

## ACCESSORY PRODUCTS

**Aussie Skin Detail Strip 560G:** 13" wide Aussie Skin 560G detail membrane without sand used for detailing penetrations, corners, and overlaps.

**Aussie Skin Sanded Tape:** 4 in. wide accessory tape, with sand adhered to one side, and pressure sensitive adhesive on the back side. Used to tape corners, edges, penetrations, and un-sanded exposed areas.

**Aussie Skin Dual-sided Tape:** 4 in. wide double-sided stick tape. Double Sided Tape may be applied on both horizontal and vertical Aussie Skin waterproofing applications and is also used in detailing the Aussie Skin waterproofing system in corners, edges, penetrations.

**Aussie Swell Red Waterstop:** Active swelling concrete joint waterstop used around penetrations and applicable concrete joints.

**Aussie Sealant M:** Marine grade single component polyether sealant/adhesive. Used to adhere Aussie Swell Red Waterstop, around penetrations, and at terminations.

**Aussie Clay 590:** Waterproofing membrane composed of granule bentonite needle-punched between a woven & non-woven geotextile. Used in conjunction with Aussie Skin 560G in hydrostatic shotcrete applications.

**AVM Drain Board 6000:** Drainage composite composed of a molded core profile core & a filter fabric. Used to remove hydrostatic presence in non-hydrostatic conditions. Can also improve substrate conditions.

**AVM Bottom Drain:** Thickened base drain composite designed to collect water from sheet drainage pales and then discharge water through collector pipes to collection system.

**Aussie Tube:** 1/2 in. wide permeable tube installed prior to concrete placement, with packers set at 25 ft. on center. Inject after concrete cure. Provide min. 2-1/2 in. concrete cover on all sides. Stagger end laps of hose min. 2 in. Used in trouble areas and in cold joints as a waterstop.

**Termination Bar:** Extruded-aluminum or formed-stainless-steel bars with upper flange to receive sealant. Used to terminate membrane at grade or during transitions.

**Spray Adhesive:** Super 77 by 3M or approved equal. Environmentally friendly, spray adhesive for drainage panel filter fabric lap joints.

**Staples:** Galvanized staples approved by membrane manufacturer. Staples for securing vertical waterproofing panels to wood lagging prior to concrete placement.

**Tie Back Cover:** 4", 6", & 8" heavy duty plastic used to cover tie-backs during concrete placement.

## LIMITATIONS

Aussie Skin 560G should only be installed after proper substrate preparation has been completed and is appropriate to receive waterproofing. Use Aussie Skin 560G with reinforced shotcrete walls or cast-in-place walls, conforming to ACI 506 Core Grade 1 or 2; minimum 8" thick. For shotcrete applications in hydrostatic conditions, Aussie clay 590 will need to be installed in conjunction with the Aussie Skin 560G. Do not use stay-in-place concrete forming, use removable forming products only. Aussie Skin 560G is designed for pre-applied applications. Do not use Aussie Skin 560G in any application where new concrete is not directly placed against the membrane, such as post applied backfill wall conditions.

# SECTION 1 – UNDERSLAB INSTALLATION

Aussie Skin 560G is engineered for use under reinforced foundation concrete slabs. Aussie Skin 560G cannot be used when protection slabs are placed over the membrane prior to the foundation slab. Aussie Skin 560G can be installed over an unreinforced mud slab or compacted earth/gravel. Complete all required elevator pit, sump pit, grade beam and piling work prior to installing the Aussie Skin 560G over the main slab area. All areas should be tied into the underslab waterproofing to create proper continuous installation forming a monolithic barrier throughout the underslab.

## 1.1 – Substrate

Prior to installing the Aussie Skin 560G, the substrate must be prepared to meet the installation requirements. Aussie Skin 560G can be placed on compacted earth/crushed stone or a prepared non-reinforced mud slab.

Earth or Crushed Stone: Earth/sand substrates should be compacted to a minimum of 85% Modified Proctor Density. The substrate must be free of loose aggregate and sharp protrusions. Avoid curved or rounded substrates. Ensure substrate is well compacted to avoid displacement of substrate due to traffic or concrete placement. Grout around all penetrations such as utility conduits, etc. for stability.

Unreinforced Concrete Rat Slab: Provide uniform, broom finished concrete substrate. Infill voids, honeycombs and gaps greater than 1/2 in. deep with grout. Grind down all projections, ridges, and sharp fins greater than 1/4 in.

## 1.2 – INSTALLATION: General

Install the Aussie Skin 560G over the prepared substrate with the HDPE fil side to the substrate and the granulated surface facing up. Stagger end laps a minimum of 12" to avoid a build-up of layers. Accurately position succeeding sheets to overlap the previous sheet along the selvedge. Ensure the underside of the succeeding sheet is clean, dry and free from contamination before attempting to overlap. Gently wipe with a rag if there is dirt or debris on the underside. Peel back the plastic release liner from between the overlaps as the two layers are bonded together. Ensure a continuous bond is achieved without creases and roll firmly with a heavy roller. See **Figure 1.1** for standard overlap spacing.

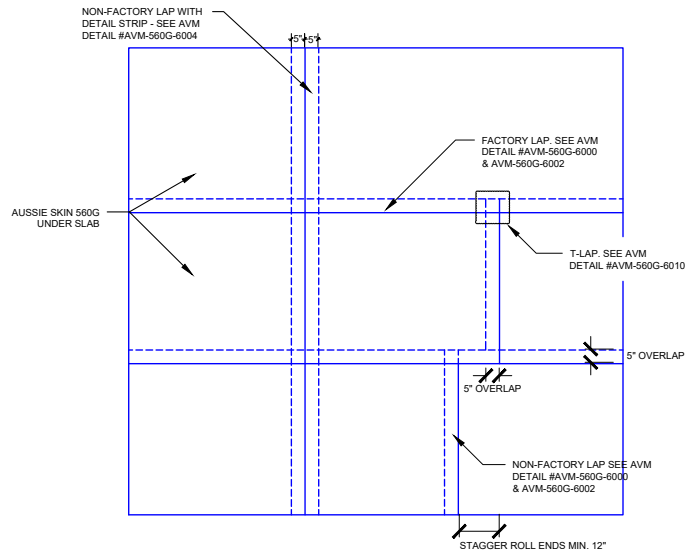
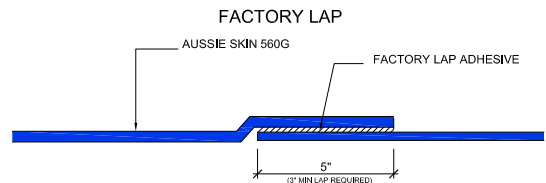

FIGURE 1.1 – STANDARD OVERLAP SPACING

Whenever the slab is placed in sections, the membrane should be extended a minimum of 12" beyond the slab placement to ensure that a proper tie in can be completed when tying into new material. These 12" tail sections should be protected from foot traffic and damage. **Figures 1.2 & 1.3** will show the single selvedge edges. **Figures 1.4 & 1.5** will show the Dual Salvage Edges.



Important Note: When installing the "Factory Lap", The Installation procedure should be as follows:  
 1) Remove the black plastic film from the factory lap to expose the adhesive.  
 2) Lay down the 2nd layer of Skin over the exposed Adhesive. (leave 1/8"-1/4" of adhesive exposed) Roll the steel roller over the 2nd layer of skin several times while applying significant pressure.  
 3) Verify seam is completely and properly bonded.

FIGURE 1.2 – SINGLE SALVAGE EDGE FACTORY LAP

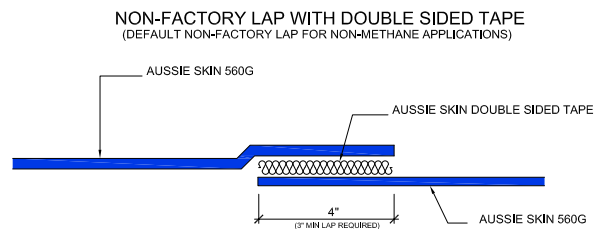

Important Note: When installing the "Non-Factory Lap", The Installation procedure should be as follows:  
 1) Remove the black plastic film from one side of the double-sided tape.  
 2) Lay down the Double-Sided Tape on the sanded side of the first layer of Aussie Skin.  
 3) THOROUGHLY COMPRESS THE DOUBLE-SIDED TAPE ONTO THE SANDED SIDE OF THE AUSSIE SKIN USING AVM'S APPROVED STEEL ROLLERS. (ROLL THE STEEL ROLLER OVER THE TAPE SEVERAL TIMES WHILE APPLYING SIGNIFICANT PRESSURE)  
 4) Carefully remove the clear film (2nd layer of film) from the Double-Sided Tape.  
 5) Lay down the 2nd layer of Skin over the exposed double-Sided Tape. (Leave 1/8"-1/4" of tape exposed) Roll the steel roller over the 2nd layer of skin several times while applying significant pressure.  
 6) Verify seam is completely and properly bonded.  
 7) If multiple pieces of Double-Sided Tape are needed, overlap them.

FIGURE 1.3 – SINGLE SALVAGE EDGE NON-FACTORY LAP

FACTORY LAP - DUAL SALVAGE EDGE

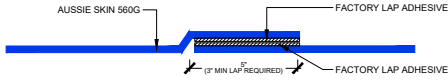

Important Note: When installing the "Factory Lap", The Installation procedure should be as follows:  
 1) Remove the black plastic film from the factory lap on the bottom sheet to expose the adhesive.  
 2) Remove the black plastic film from the factory lap on the top sheet and lay down onto 1st layer of Skin over the exposed Adhesive.  
 (Leave 1/8" - 1/4" of adhesive exposed) Roll the steel roller over the 2nd layer of skin several times while applying significant pressure.  
 3) Verify seam is completely and properly bonded.

FIGURE 1.4 - DUAL SALVAGE EDGE FACTORY LAP

NON-FACTORY LAP

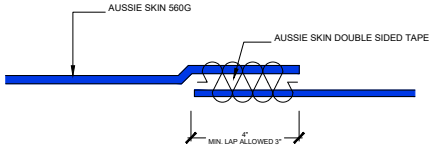

Important Note: When installing the "Non-Factory Lap", The Installation procedure should be as follows:  
 1) Remove the black plastic film from one side of the double-sided tape.  
 2) Lay down the Double-Sided Tape on the sanded side of the first layer of Aussie Skin.  
 3) THOROUGHLY COMPRESS THE DOUBLE-SIDED TAPE ONTO THE SANDED SIDE OF THE AUSSIE SKIN USING AVM'S APPROVED STEEL ROLLERS. (ROLL THE STEEL ROLLER OVER THE TAPE SEVERAL TIMES WHILE APPLYING SIGNIFICANT PRESSURE)  
 4) Carefully remove the clear film (2nd layer of film) from the Double-Sided Tape.  
 5) Lay down the 2nd layer of Skin over the exposed double-Sided Tape. (Leave 1/8" - 1/4" of tape exposed) Roll the steel roller over the 2nd layer of skin several times while applying significant pressure.  
 6) Verify seam is completely and properly bonded.  
 7) If multiple pieces of Double-Sided Tape are needed, overlap them!

FIGURE 1.5 - DUAL SALVAGE EDGE NON-FACTORY LAP

There are situations when it is needed to use the detail strip to connect two sections of the Aussie Skin 560G. The 13.1" strip has the adhesive backing on the HDPE allowing the strip to overlap a minimum of 5" on each of the Aussie Skin sheets. This is shown in **Figure 1.6**

NON-FACTORY LAP WITH DETAIL STRIP  
 (DEFAULT NON-FACTORY LAP FOR METHANE APPLICATIONS)

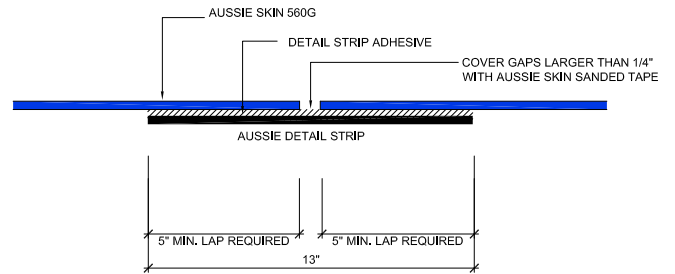

FIGURE 1.6 - NON-FACTORY LAP WITH DETAIL STRIP

There may be instances where it is required to lap onto two separate membrane sheets. This is referred to as a T-Lap, as the three corresponding sheets that are over lapping will form a T. **Figure 1.7** will show the sequencing on how to accomplish this.

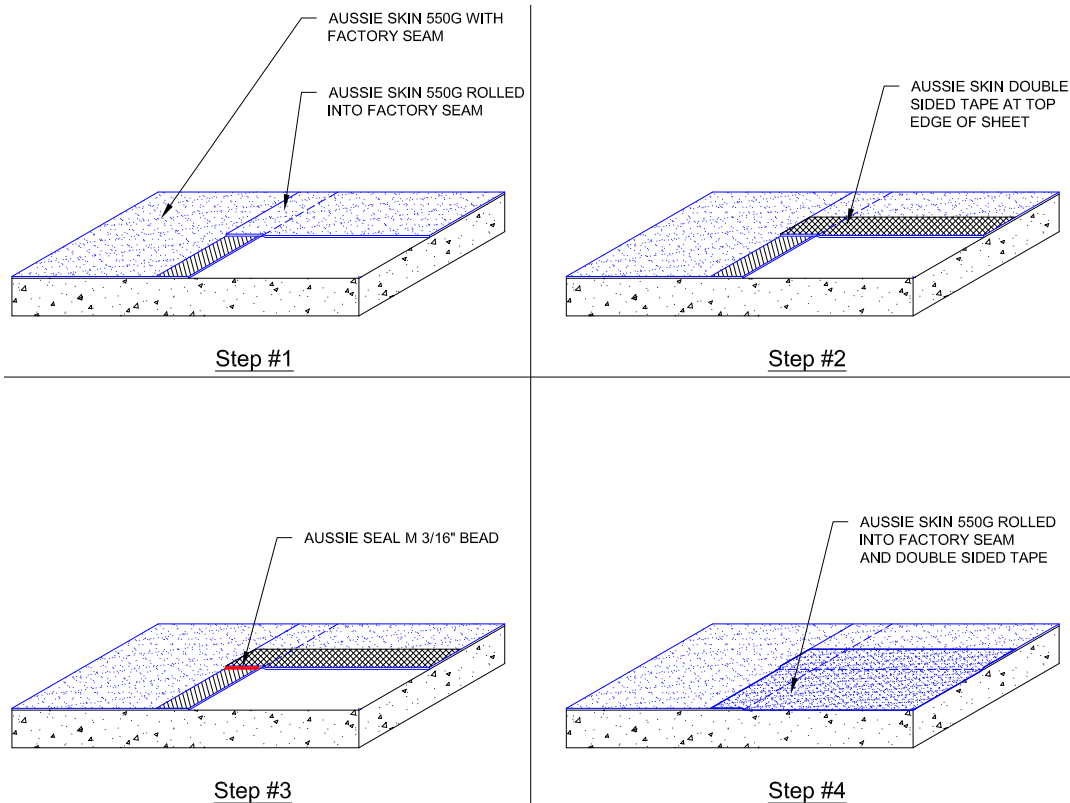
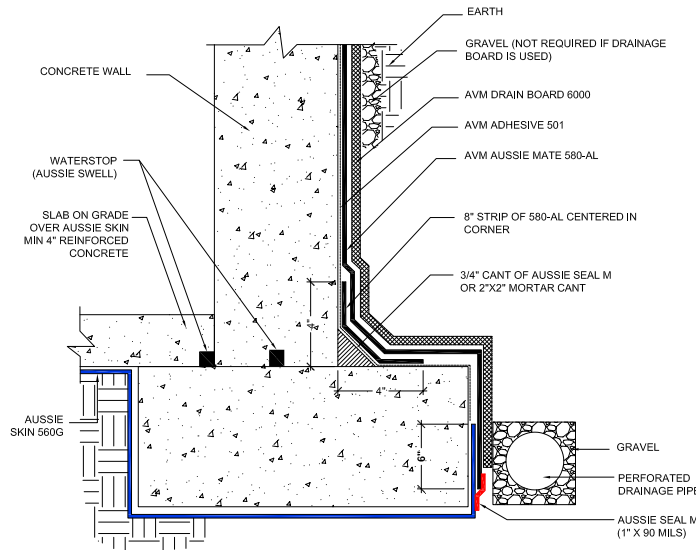

FIGURE 1.7 - SEQUENCING OF THE T-LAP



**1.3 - INSTALLATION: Raised Slabs, Slab on Grade, and Wrapped Footings**

Tying underslab waterproofing to vertical waterproofing is necessary in hydrostatic conditions in order to create a bathtub around the building preventing that hydrostatic pressure from entering the building, Aussie Skin 560G can only be installed in conditions with fresh concrete placement so it needs to tie into another membrane whenever there is a post applied application up the vertical wall. Aussie Swell Red Waterstop should be placed at the wall/slab joint. An Aussie Swell Red Waterstop Red should also be placed at the wall/slab on grade joint if applicable. **Figure 1.8** shows the Aussie Skin 560G wrapped under the footing and tying into AVM's Aussie Mate 580-AL.



**FIGURE 1.8 - 560G UNDER SLAB TYING INTO AUSSIE MATE 580-AL**

**1.4 - INSTALLATION: Pipe Penetrations**

For slab pipe penetrations, cut the Aussie Skin 560G to fit as close around the penetration as possible. Place Aussie Seal M around the pipe penetration extending 2" around the penetration to fill any void between the Aussie Skin 560G and the penetration and 2" up the penetration with a 3/4" fillet at the base. An Aussie Swell Red Waterstop will be placed around the pipe penetration with a minimum of 3" of concrete coverage. See **Figure 1.9**.

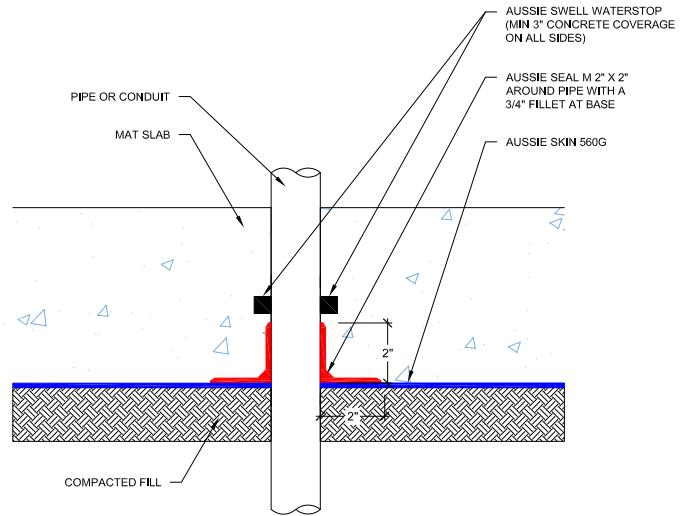

**FIGURE 1.9 - PIPE PENETRATION THROUGH SLAB**

With multiple pipe penetrations, ensure there is 6" between each pipe and install the same as above. When the 6" cannot be achieved like in pipe bank applications, a pitch pan would be required. In this scenario, cut the membrane so it is butted against the outside penetrations as closely as possible. Create a metal pitch pan out of sheet metal and place it around the cluster of pipes. Install AVM System 520 into the pitch pan at a minimum of 2" thick. Lap Aussie Skin Sanded Tape from the Aussie Skin membrane over the pitch pan to create a continuous granule surface. See **Figure 1.10** for reference.

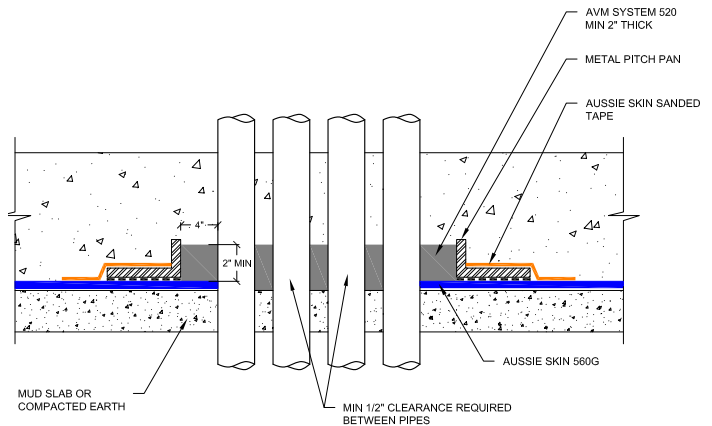

**FIGURE 1.10 - PITCH PAN PIPE BANK DETAIL**

1.5- INSTALLATION: Grade Beams & Pile Caps

Installation of grade beams and pile caps are dependent on whether the condition is hydrostatic or non-hydrostatic. In hydrostatic conditions, it is important to keep the waterproofing continuous to prevent intrusion of water.

For non-hydrostatic conditions, the Aussie Skin 560G will be installed 4" minimum onto the pile cap or grade beam and terminated. Aussie Seal M will then be placed on the 4" of Aussie Skin 560G that extends onto the grade beam/pile cap and extend an additional 4" onto the grade beam/pile cap. This will be shown on Figure 1.11.

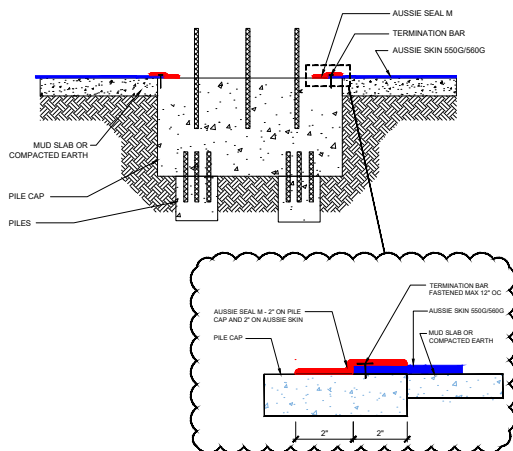

FIGURE 1.11 - NON-HYDROSTATIC PILE CAP DETAIL

For hydrostatic conditions, the detailing will be different as to ensure there is not a break in the waterproofing. One way to do this is to install the Aussie Skin underneath the grade beam as shown on Figure 1.12.

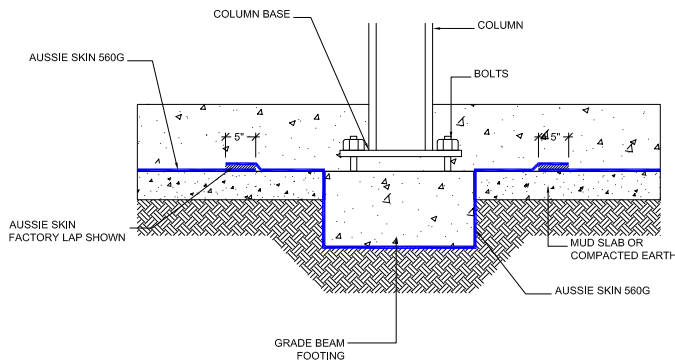

FIGURE 1.12 - WRAPPED GRADE BEAM

When this is not possible, Aussie Skin 560G will terminate similarly as the non-hydrostatic detail. However, the grade beams and pile caps can be covered with the fluid applied polyurethane AVM System 520 which will tie into the Aussie Skin 560G to ensure the waterproofing is continuous. The tie-in between the 520 System and

the 560G Aussie Skin for a grade beam is shown in Figure 1.13 on the next page. Figure 1.14 will show the tie in with a pile cap. Note the use of silica sand with the AVM System 520, this is up to the design team.

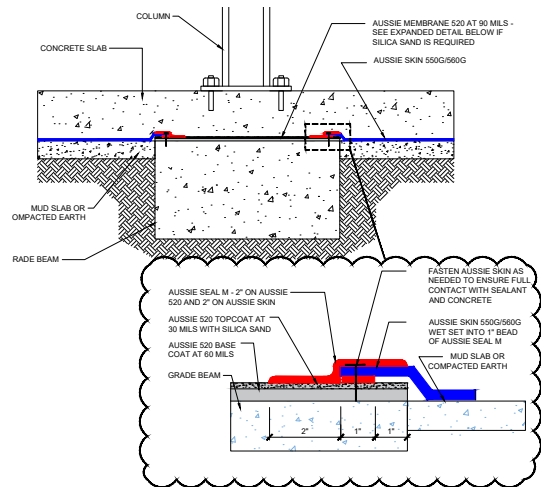

FIGURE 1.13 - HYDROSTATIC GRADE BEAM DETAIL

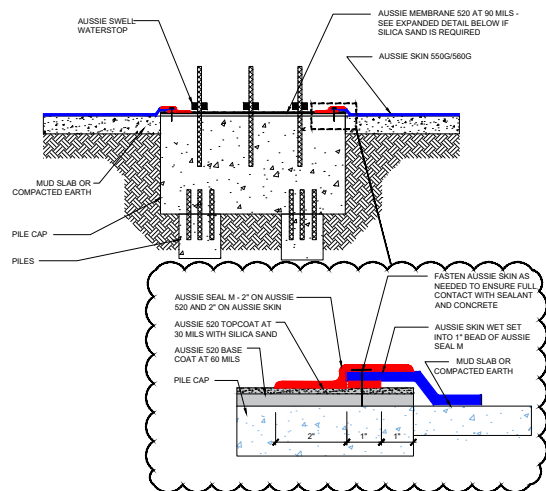

FIGURE 1.14 - HYDROSTATIC PILE CAP WITH AUSSIE SKIN 560G

1.6 - INSTALLATION: Elevator Pits

Aussie Skin 560G will should be placed on vertical surfaces and on the substrate under slab to provide a continuous envelope around the elevator pit. Ensure the soil cut is smooth and soil to provide a proper substrate for the Aussie Skin 560G to be installed over. For unstable soil conditions, it is recommended to install a retaining wall to contain the soil. Extend the membrane a minimum of 12" onto the horizontal surface when you bring up the pit wall. Overlap it 5" onto the underslab membrane that it is tying into. Please refer to Figure 1.15 for this installation.

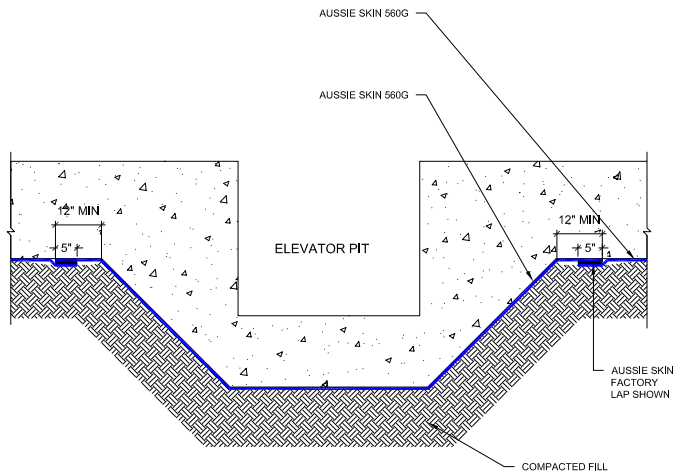

FIGURE 1.15 - ELEVATOR PIT

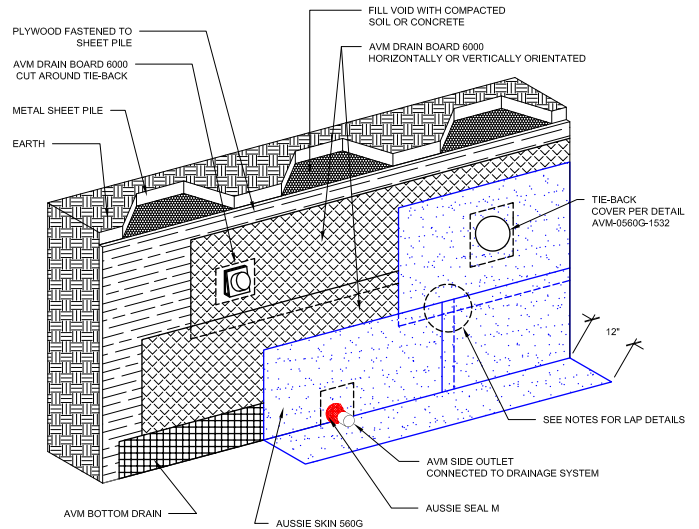

FIGURE 1.17 - SHEET METAL PILING

**1.7 - INSTALLATION: Edge of Slabs, Transition to Propertyline**

When transitioning from underslab to a propertyline application, such as wood pile and lagging (Figure 1.16), sheet metal piling, and shotcrete retaining walls, extend the vertical base course sheet a minimum of 12" onto the underslab. The granule side of the membrane should be facing the installer for both the horizontal and vertical installation. Form the membrane tightly into the corner. Try to avoid excessive wrinkling of the membrane. Hang the membrane that runs vertically up the shoring wall by fastening the outer edge of the factory seam so there is a minimum of 2" of exposed adhesive toward the inside of the membrane to provide for proper lap adhesion. When the shoring wall is composed of metal sheet piling, fasten plywood over the sheet metal piling and fill all voids with compacted soil or concrete to give the membrane a proper substrate as shown in Figure 1.17.

Inside and outside corners are completed in steps to ensure that the proper overlaps and continuity is administered throughout the installation. Figure 1.18 will depict the steps to complete a proper inside corner detail while Figure 1.19 will provide the instructions for a proper outside corner at the bottom of a wall.

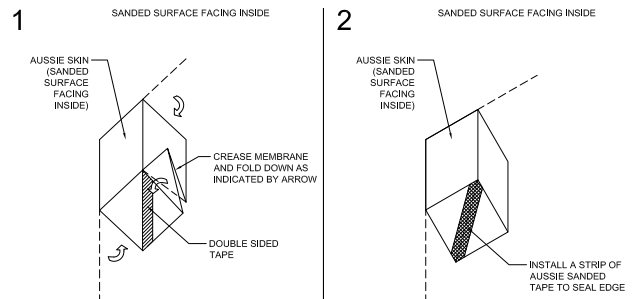

FIGURE 1.18 - INSIDE CORNER

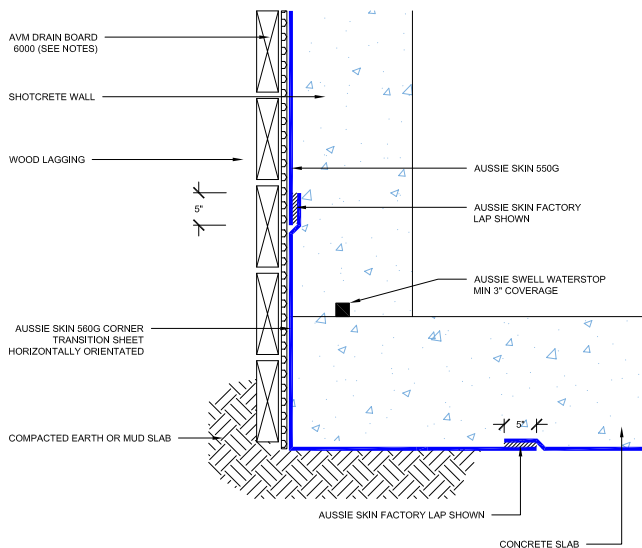

FIGURE 1.16 - UNDERSLAB TO PROPERTYLINE TRANSITION

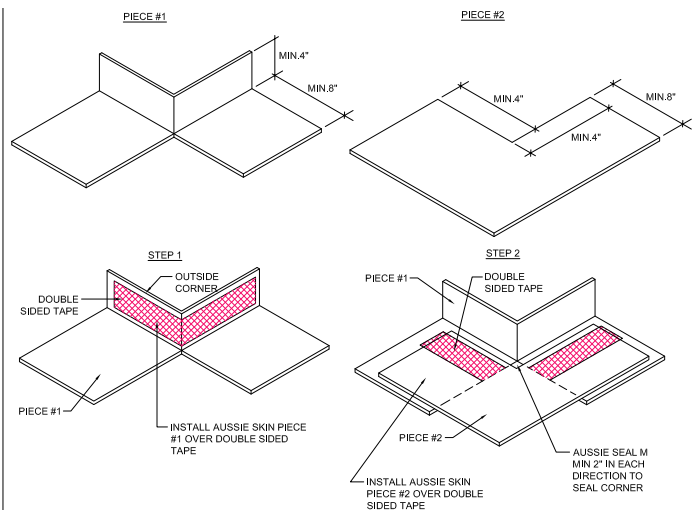

FIGURE 1.19 - OUTSIDE CORNER

## SECTION 2 - PROPERTYLINE INSTALLATION

Aussie Skin 560G is designed to be installed in blindside or propertyline conditions making it an excellent choice in both cast in place or shotcrete applications for both hydrostatic and non-hydrostatic conditions. Hydrostatic shotcrete conditions will vary installation guidelines. Aussie Skin 560G can be installed over wood pile and lagging, sheet metal piling or shotcrete retaining walls. When installing the Aussie Skin 560G in propertyline conditions, always ensure the HDPE liner is facing the shoring while the granule side is facing the installer. For non-hydrostatic conditions, it is recommended that the AVM 6000 Drain Board is used to collect water and carry it into a drainage system.

### 2.1 - SUBSTRATE:

Prior to installing the Aussie Skin 560G, the substrate must be prepared to meet the installation requirements. Penetrations should already be in place to ensure proper detailing at the time of installation.

**Sheet Piling:** Use concrete, plywood, board insulation, or drainage panel or other approved facing over sheet piling to provide support to the membrane.

**Wood Lagging Shoring:** Extend to the lowest level of the waterproofing installation with any voids or cavities exterior of the lagging timbers filled with compacted soil or cementitious grout. Interior surface of lagging boards should be planar and tight together with gaps less than 1/2 in. Gaps in excess of 1/2 in. should be filled with cementitious grout, compacted soil, wood, extruded polystyrene (20 psi minimum) or AVM approved polyurethane spray foam. If insulation protection board or drainage panel is utilized over the lagging, the allowable gaps may be up to 2 in. wide.

### 2.2 - INSTALLATION: General

Once the slab to wall corner transition has been installed, the membrane can be installed in either a vertical or horizontal fashion up the remaining wall. While installing the Aussie Skin 560G up the wall, power actuated fasteners or staples will need to be used to help hold the membrane in place until it is time to receive the concrete placement. AVM recommends the use of 1" metal washer head fasteners when hanging the membrane. Fasteners should be installed towards the outer edge of the factory seam so that there is a minimum 2" of exposed adhesive toward the inside of the membrane, to allow for proper lap adhesion. Typical distance between fasteners is approximately every 24"- 36" on center. Depending on substrate and length of fastener, additional fasteners may be required to hold membrane in place, particularly when using the 2-meter-wide rolls. When using fasteners in locations away from the outer edge and more centered in the membrane, patching the fasteners is required. The style of patching is dependent on whether the membrane is in the water table or not and if the fastener is flush to the membrane. The below Figures will show these conditions.

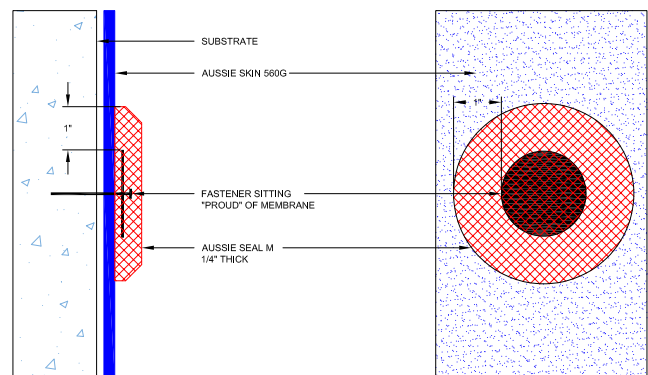

FIGURE 2.1 - NON-FLUSH FASTENER DETAIL

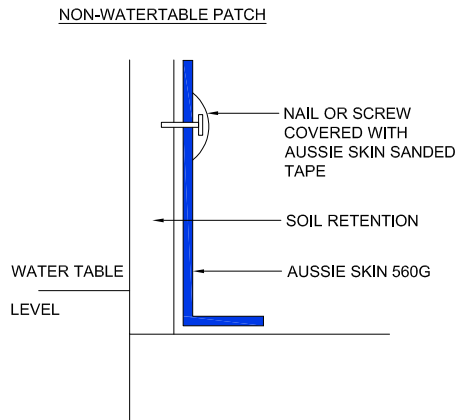

FIGURE 2.2 - NON-WATER TABLE PATCH

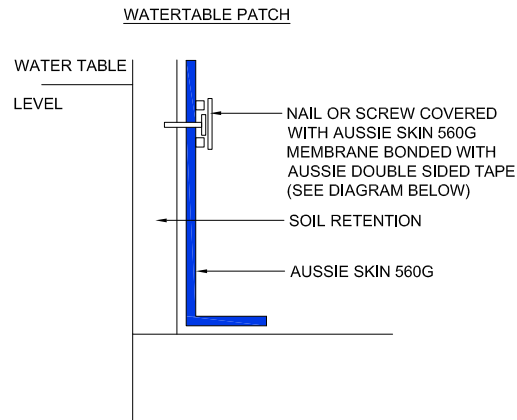

FIGURE 2.3 - WATER TABLE PATCH

**Below Water Table Installations:** All nails, screws, etc., used to hang the Aussie Skin below the water table must be non-rusting and sealed with a 3"x3" patch of Aussie Skin 560G bonded with Aussie Tape.

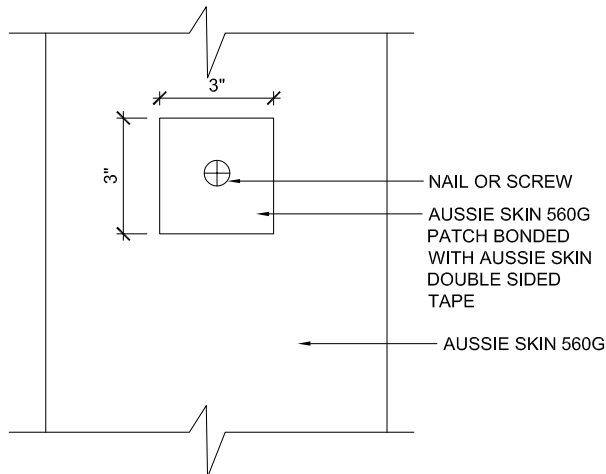

FIGURE 2.4 - PATCHING AUSSIE SKIN 560G

### 2.3 - INSTALLATION: Pipe Penetrations

Much like the detailing done for underslab conditions, pipe penetrations for propertyline applications begin by cutting the Aussie Skin 560G to fit as close around the penetration as possible. Place Aussie Seal M around the pipe penetration extending 2" around the penetration to fill any void between the Aussie Skin 560G and the penetration and 2" up the penetration with a 3/4" fillet at the base. An Aussie Swell Red Waterstop will be placed around the pipe penetration with a minimum of 3" of concrete coverage. Shown on **Figure 2.5** on the following page. When there are sleeved pipe penetrations, concrete work will need to include filling the gap between the pipe and the sleeve with a non-shrink cementitious grout, mechanical seal by others and then an Aussie Swell Red waterstop on the outside of the sleeve. See **Figure 2.6** for detail. For multiple pipe penetrations, detail like a singular but ensure there is a minimum of 6" between each penetration. For other pipe penetrations, refer to the AVM Technical Team for an approved detail.

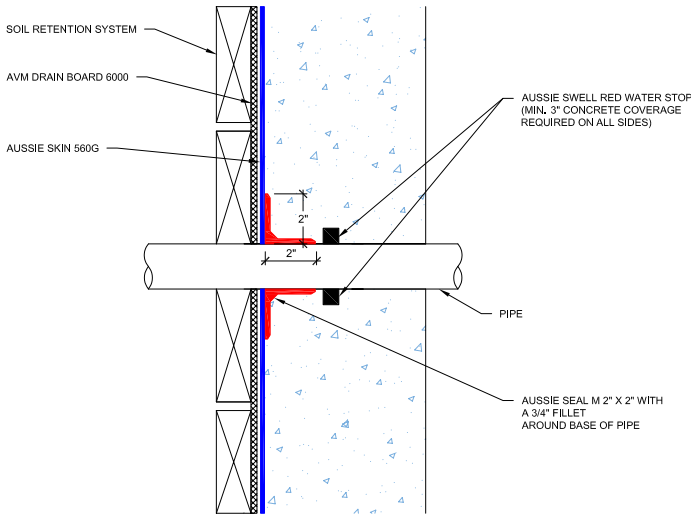

FIGURE 2.5 - PIPE PENETRATION THROUGH WALL

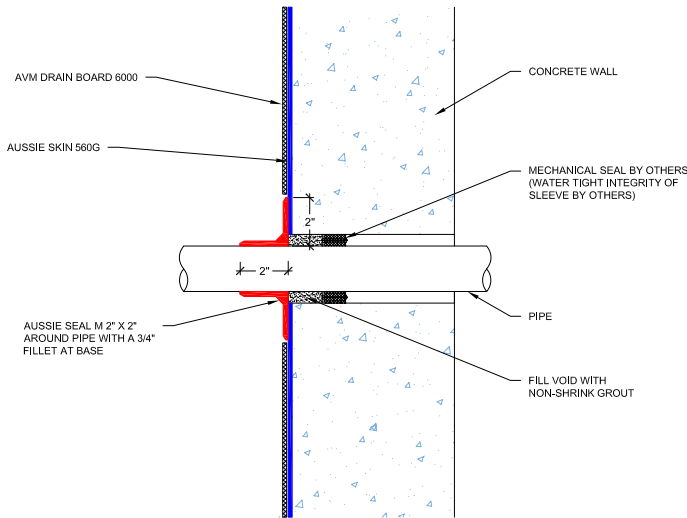

FIGURE 2.6 - CORED PIPE PENETRATION

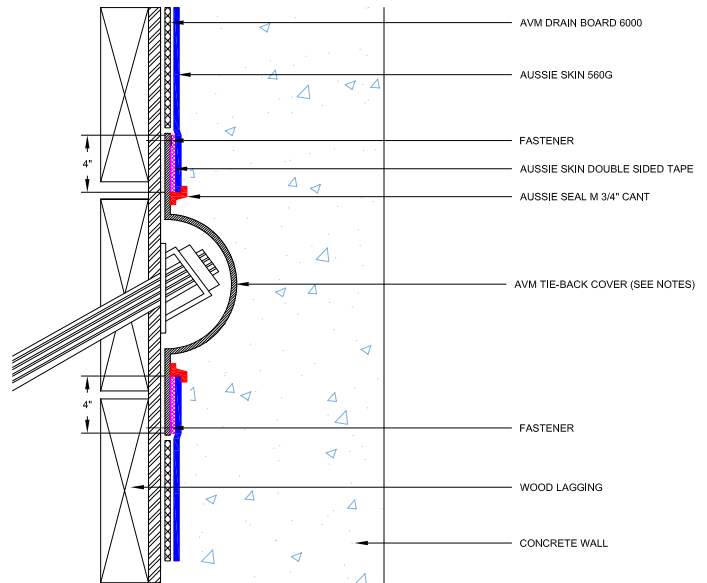

FIGURE 2.7 - TIE BACK COVER DETAIL

Detensioning the tie-back by the way of boxing it out is another common way to waterproof tie-backs. With this approach, install the Aussie Skin tightly up to the tie-back. Forms or a sonotube will be placed around the tie-back to box it out during the concrete placement. Once the placement is completed, the tie-back will then be detensioned. From there, smooth any edges with Aussie Seal M. A patch of Aussie Skin 560G will be placed over the area where the tie-back was detensioned extending 4" past the perimeter. Aussie Skin Double-Sided Tape will need to be used to adhere the patch. An Aussie Swell Red will be placed around the perimeter of the box-out before the box-out is filled with non-shrink grout or concrete. **Figure 2.8** shows this.

**2.4 - INSTALLATION: Tie-Backs**

Tie-backs can be waterproofed a few different ways with the Aussie Skin 560G: using an AVM Tie-Back Cover (recommended) and boxing out and detensioning the tie-back. If neither of these methods can be achieved, refer to the AVM Technical Team. When using an AVM Tie-Back cover, select the proper sized Tie-Back Cover (4", 6", 8") to fit over the tie-back and allow proper concrete coverage per project requirements. Once the Tie-Back Cover is over the tie-back, place a 4" strip of Aussie Skin Double-Sided Tape on the flaps of the Tie-Back Cover. Run the Aussie Skin 560G over the other edge of the Aussie Skin Double-Sided Tape so it is adhered and place a 3/4" cant of Aussie Seal M to seal the edges of the Aussie Skin 560G against the Tie Back Cover. This is shown on **Figure 2.7**.

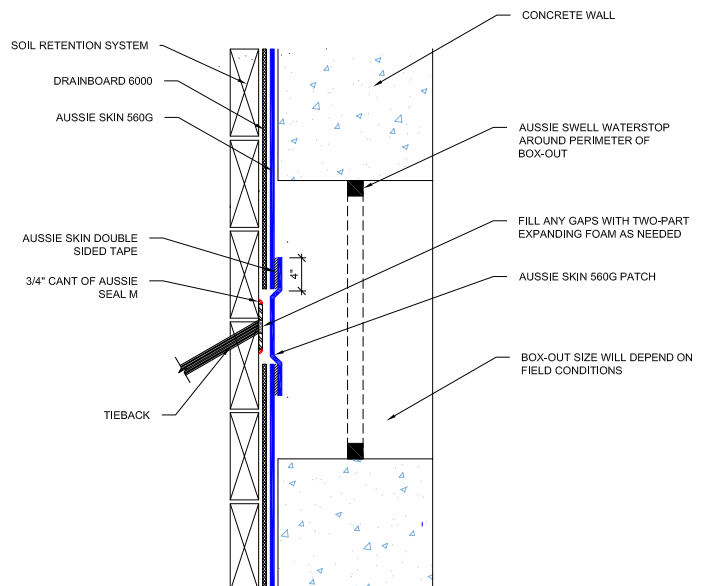

FIGURE 2.8 - DE-TENSIONING OF TIE BACK W/ BOX OUT

2.4 - INSTALLATION: Lagging Board Removal at Grade & Grade Termination

Prior to installing Aussie Skin 560G to finished grade, install a ½” thick cementitious wall board centered over steel soldier pile from finished grade elevation to the specified depth that the top of the wood lagging and soldier pile will be removed. This will protect the membrane from getting burned or damaged during removal. **Figure 2.9** on the next page will show this. Any areas damaged during removal of the soldier pile and lagging will need to be repaired. The Aussie Skin 560G can then terminate or tie into an above grade membrane. **Figure 2.10** shows typical grade termination.

\*Note: Formwork should not be removed until a minimum 72 hours after concrete placement.

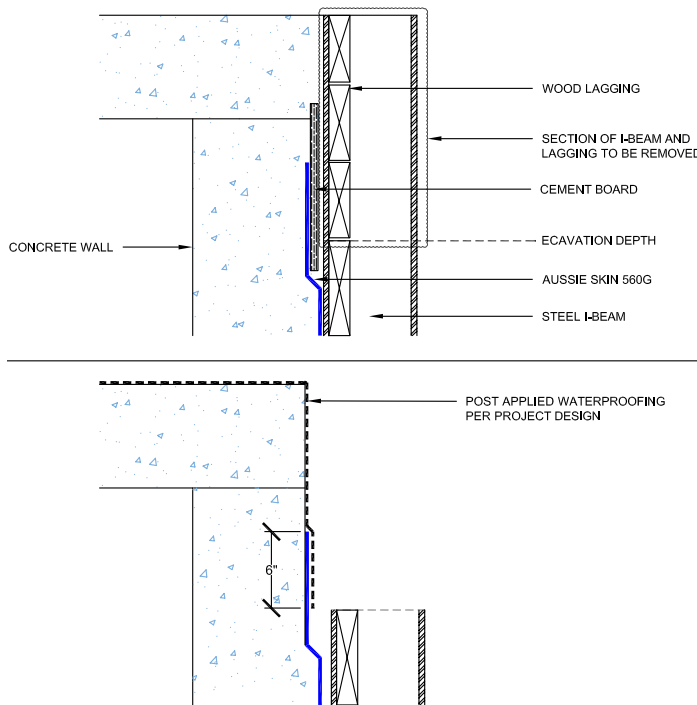

FIGURE 2.9 - CEMENT BOARD AT GRADE

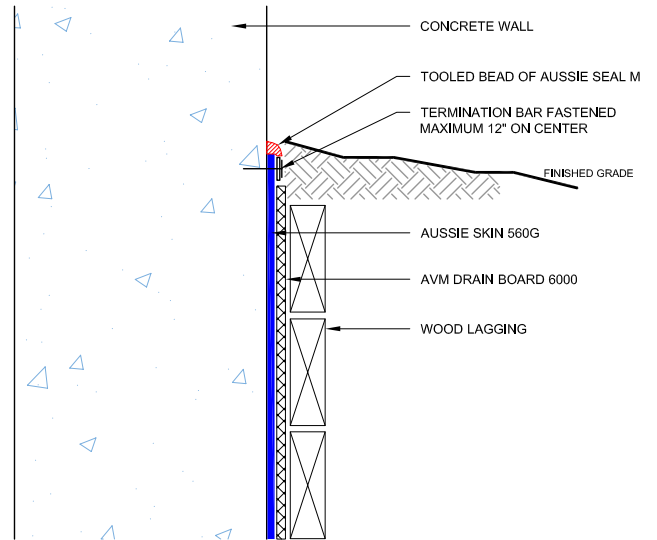

FIGURE 2.10 - GRADE TERMINATION

## SECTION 3 – HYDROSTATIC SHOTCRETE (DUAL LAYER SYSTEM)

Shotcrete, or concrete being projected onto a surface at high velocity pneumatically, is becoming a more popular option when placing concrete because it does not require forms. While it reduces the time to place concrete, there are some challenges when it comes to shotcrete. Voids in the concrete and cracks forming due to shrinkage can be common issues with shotcrete applications. These issues can be problematic to the waterproofing, particularly when hydrostatic conditions exist. A more robust system is required to overcome these problems to ensure a watertight building. This robust system consists of a dual layer system, those layers being the Aussie Skin 560GG and the Aussie Clay 590. This section will include the installation instructions for the Dual Layer system for Hydrostatic Shotcrete conditions.

**\*NOTE: For non-hydrostatic conditions, installation will follow the instructions under Section 2 in this manual unless otherwise stated by the design team. Dual Layer system is only required for hydrostatic conditions.**

### 3.1 – INSTALLATION: Wall top Slab Transition

When installing the dual layer system, it is important to sequence the membranes in the correct fashion. The Aussie Clay 590 (for information on all variations please see Aussie Clay 590 product manual) will always be installed over the shoring with the grey woven geotextile facing the installer. From there, the Aussie Skin 560G will be placed over the Aussie Clay 590 with the granule side facing the installer.

The dual layer system installation begins with the wall to slab transition. An Aussie Clay 590 transition sheet should first be placed at the corner of the underslab to vertical installation. This transition sheet should extend a minimum of 12" onto the underslab with the remaining sheet placed vertically up the shoring. The next Aussie Clay sheet should be placed on the shoring overlapping the transition sheet a minimum of 4". Installers should then take a sheet of Aussie Skin 560GG and fold it in half horizontally. The crease formed from the horizontal fold will be placed in the corner with half the sheet extending over the 12" min Aussie Clay 590 extension onto the underslab and the other half folder up the shoring over the placed Aussie Clay 590. The Aussie Skin sheet that extends onto the underslab will then be tied into the underslab waterproofing with the standard lap as described in Section 1.2. **Figures 3.1 & 3.2** will show these transitions.

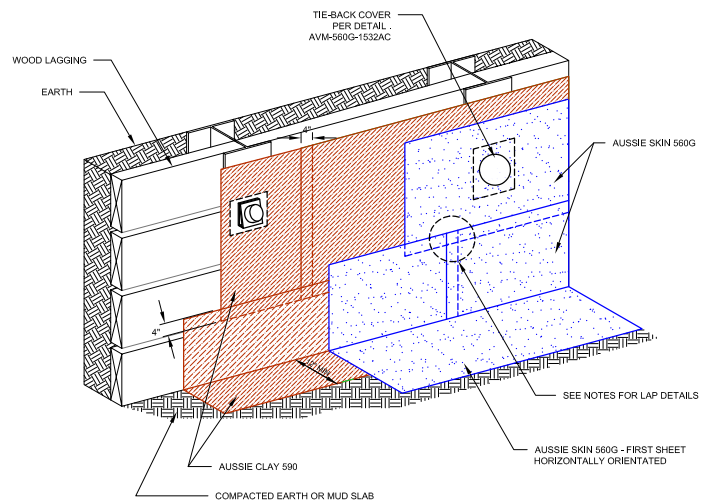

FIGURE 3.1 – DUAL LAYER UP LAGGING WALL



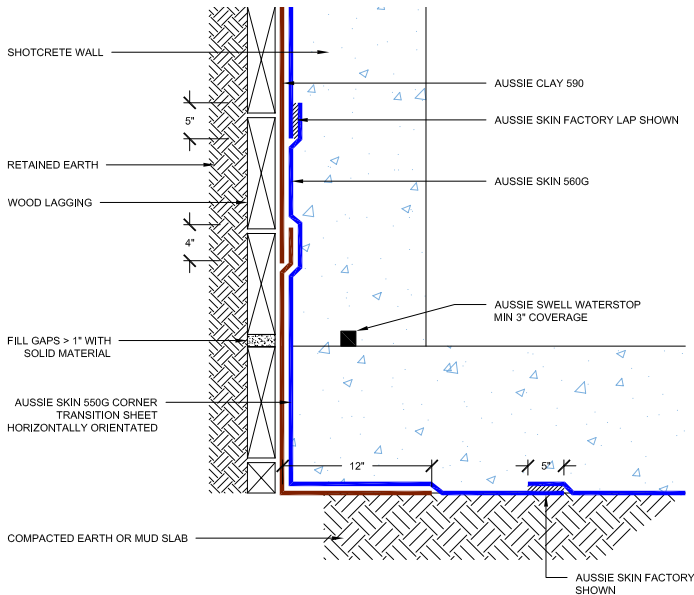

FIGURE 3.2 - DUAL LAYER TIE-IN TO UNDERSLAB WITH 5" FACTORY LAP

When the conditions call for a raised slab with a drainage system underneath the slab, the installation will be done very similarly as the above instructions. This is different if there is a non-hydrostatic condition and the design team still would like to utilize the robust dual layer system. See **Figure 3.3 & 3.4**.

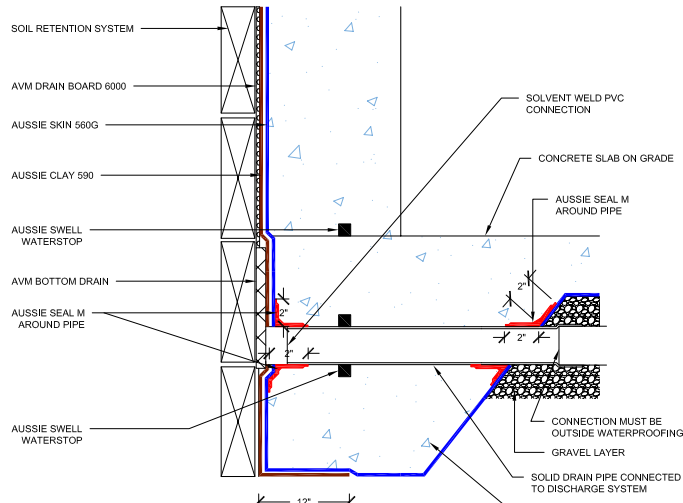

FIGURE 3.3 - NON-HYDROSTATIC RAISED SLAB

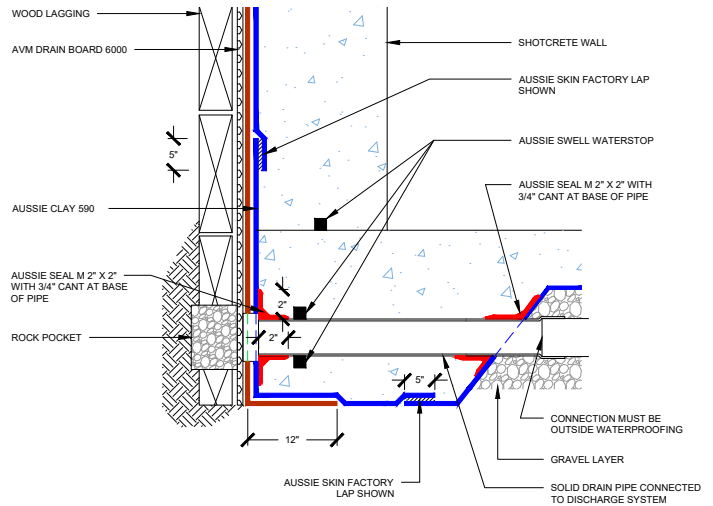

FIGURE 3.4 - ROCK POCKET DRAIN DETAIL

### 3.1 - INSTALLATION: Pipe Penetrations

When detailing pipe penetrations, cut a hole in both the Aussie Clay 590 and Aussie Skin 560GG to fit as closely to the penetration as possible. Place Aussie Seal M around the pipe penetration extending 2" around the penetration to fill any void between the Aussie Skin 560G and the penetration and 2" up the penetration with a 3/4" fillet at the base. An Aussie Swell Red Waterstop will be placed around the pipe penetration with a minimum of 3" of concrete coverage. For sleeved pipes, the sleeve needs to be filled with a non-shrink grout and a mechanical seal will be placed by others. **Figure 3.5** will show a typical sleeved pipe penetration.

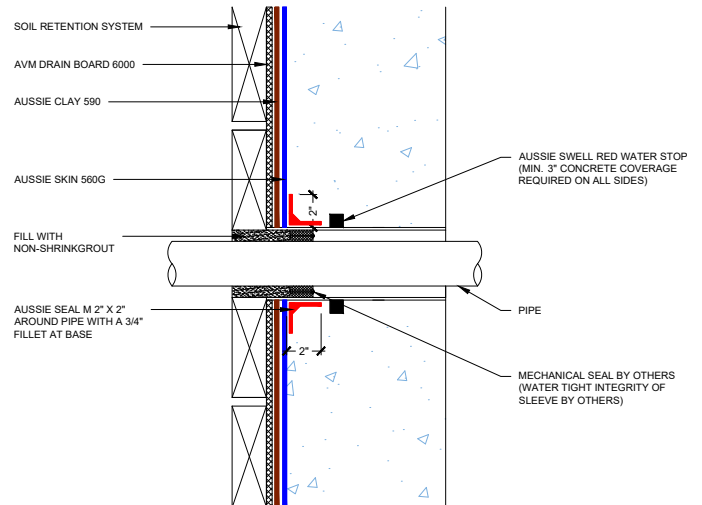

FIGURE 3.5 - SLEEVED PIPE PENETRATION

Rebar ties are going to be done in a very similar fashion as the pipe penetrations, but the Aussie Seal M will only extend 1" around the pipe penetration to fill the voids between the Aussie Skin 560G and 1" up the rebar tie. Aussie Swell Reds will be placed around the rebar tie. Use a zip tie or tie wire to hold the Aussie Swell around the rebar tie. **Figure 3.6** shows this.

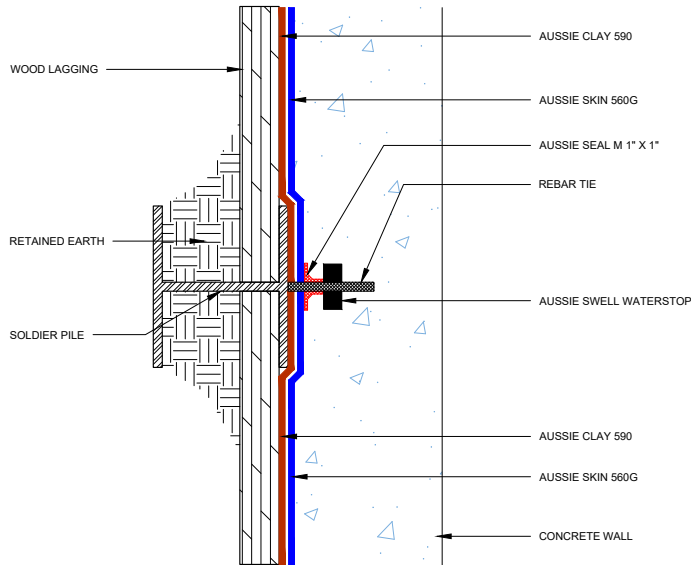

FIGURE 3.6 - DUAL LAYER REBAR TIE

**3.3 - INSTALLATION: Tie-backs, Rakers, & Soldier Piles**

As discussed in section 2.4, tie-backs can be done a few different ways: with the AVM Tie-Back Cover and by boxing-out/detensioning the tie-back. When using the AVM Tie-Back Cover, run the Aussie Clay 590 up tight against the tie-back. Place the cover over the tie-back and fasten through the Tie-Back Cover base through the Aussie Clay 590. The rest of the installation will follow the same guidelines as the installation in section 2.4. This is shown in **Figure 3.7**. When boxing the tie-back out and detensioning the tie-back, start by running the Aussie clay 590 up tight against the tie-back. Install the Aussie Skin 560GG over the Aussie Clay 590 but come 4" short of the Aussie Clay 590. Once concrete is place and the tie-back is detensioned, come over the edges of the tie-back with Aussie Clay Sealant to soften the edges. An Aussie Clay 590 patch will be placed over the Aussie Clay Sealant with the edges overlapping the Aussie Clay 590 field sheet. An Aussie Skin 560GG patch is then placed over the Aussie Clay 590 patch with the Aussie Skin 560GG patch overlapping the Aussie Skin 560GG field sheet 4". Aussie injection tubes should be placed around the perimeter of the box-out

as well as an Aussie Swell Waterstop prior to the box-out being filled with a cementitious non-shrink grout or concrete. **Figure 3.8** shows this detail.

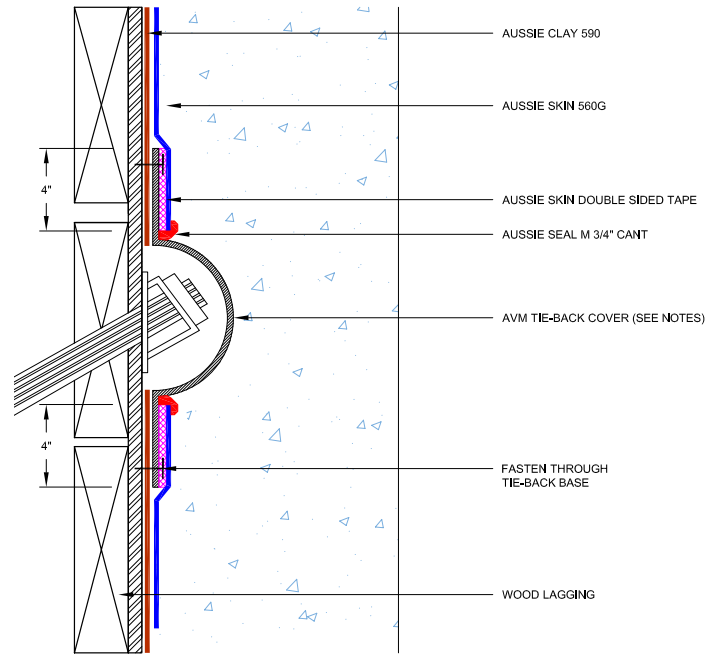

FIGURE 3.7 - DUAL LAYER SYSTEM W/ TIE BACK COVER

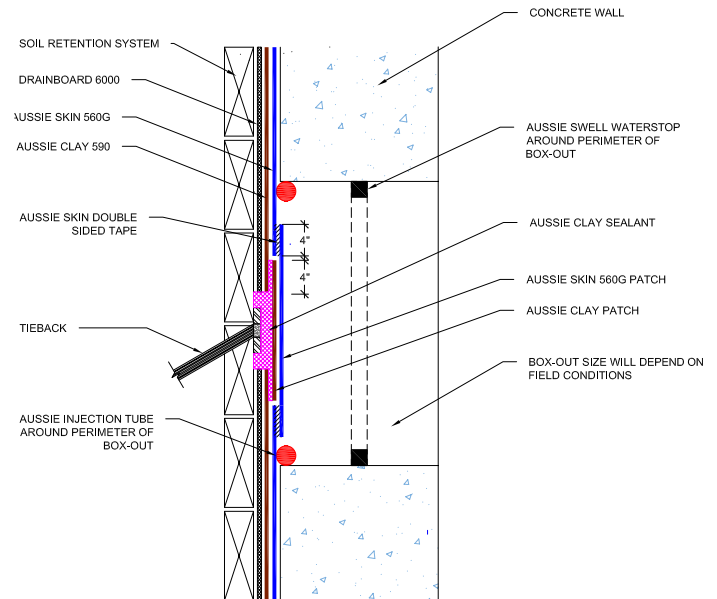

FIGURE 3.8 - DE-TENSION TIE-BACK WITH BOX-OUT

With back-lagged soldier piles, take the Aussie Clay 590 and run it to the soldier pile. Leave 4" between the pile and the Aussie Clay 590. Take the Aussie Skin 560GG field sheet and run it over the Aussie Clay 590 and as tight up against the soldier pile as possible. Use Aussie-Skin Double-Sided Tape to adhere the Aussie Skin 560GG to the Soldier Pile. Install a 2"x2" fillet of Aussie Seal M at the base of the soldier pile. Continue the 2"x2" fillet of the Aussie Seal M around the base of the pile at the underslab. Finally, install an Aussie Swell Red up the edge of the soldier pile. This is shown in **Figure 3.9**.

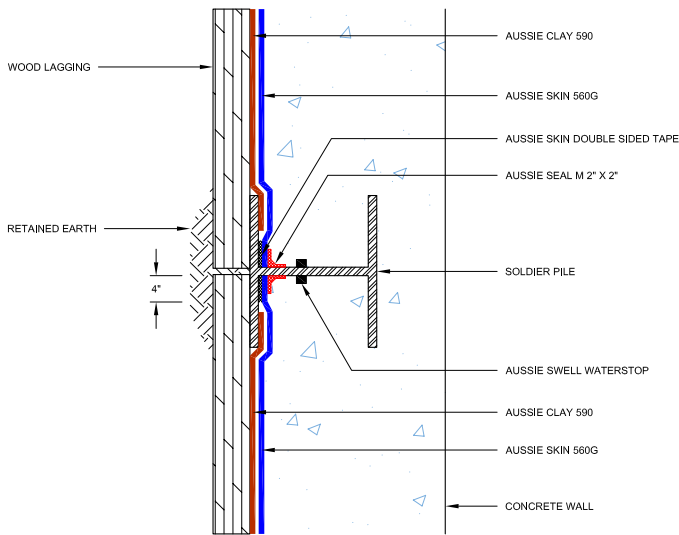

FIGURE 3.9 - DUAL LAYER BACK LAGGED SOLDIER PILE

**3.3 - INSTALLATION: Lagging Board Removal at Grade & Grade Termination**

Because of the bond that is formed from concrete being directly placed onto the Aussie Skin, terminations will need to be done after concrete placement and the bond between the Aussie Skin and the concrete has sufficiently formed. Like in a single layer system, the termination can be done with by stopping the membrane at graded or in the form of a transition to an above grade membrane. Unlike the single system grade termination detail which requires the counter flashing over the membrane at grade, the dual layer system can be terminated with a termination bar installed at the top edge of the membranes every 12" on center with a tooled bead of Aussie Seal M over the term bar. The Aussie Clay 590 will be facing the installer when working post applied. **Figure 3.10 & 3.11** shows the termination detail.

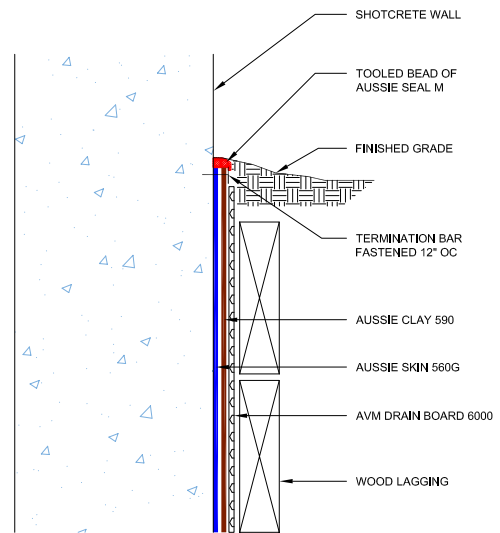

FIGURE 3.10 - GRADE TERMINATION OPTION 1

Much like in the single layer system, when lagging removal is to be done, a cement board will need to be placed between the Aussie Clay 590 membrane and the lagging board to prevent damage from occurring when the boards and soldier pile are removed. Once the pile and lagging are removed to the excavation depth, the cement board can be removed as well as the Aussie Clay 590 that extends past the excavation depth. A min of 6" of Aussie Skin 550G will need to be left over to tie into any post applied waterproofing per the project design, **Figure 3.12** will show the 2-step process of removing lagging at grade with the dual system.

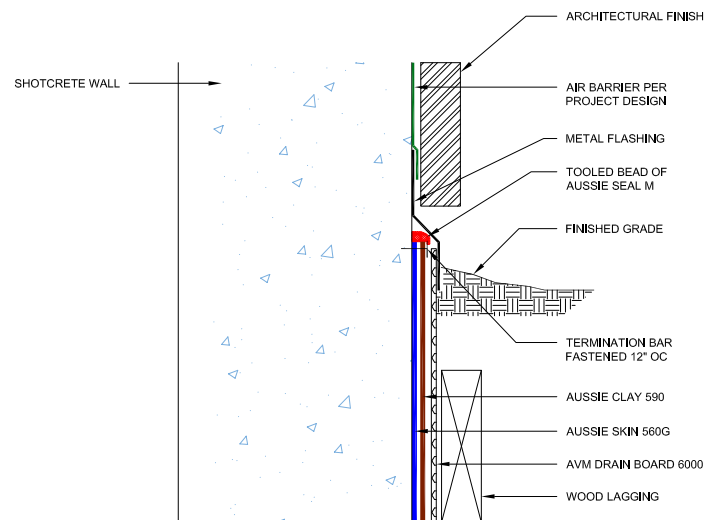

FIGURE 3.11 - GRADE TERMINATION OPTION 2

## SECTION 4 – GAS VENTILATION

Refer to the County of Los Angeles for complete ventilation requirements and the engineer of record.

## SECTION 5 – SMOKE TEST

Refer to the county of Los Angeles for complete smoke test requirements and the engineer of record. As the type and required approach will vary per project requirements.

## COLD WEATHER (20-40°) INSTALLATION

In colder temperatures, adhesives and sealants don't bond as well due to the temperatures causing reduced adhesion strength. During these conditions, additional procedures may be required to ensure proper bonding and performance.

1. Make sure to keep all Aussie skin accessories and sealant warm (approx. 70°F) A warm room or tent work well.
2. If feasible, store Aussie Skin rolls in heated areas as well.
3. Optionally can run a Leister heat welding machine (or a similar heat welding machine) over the seams as follows:
  - a. Use Leister Model Verimat 2 or a similar heat welding machine
  - b. Set Temperature to its lowest setting
  - c. Run the machine at a comfortable pace (optionally can run it at the top speed)
  - d. Check for proper adhesion once installed.
4. Detail Strips: Use the same cold weather installation procedures as factory and non-factory laps.
5. Applying double sided tapes to metal and metal I-Beams. Pre-heat the metal surfaces by lightly going over them with a heat gun or torch. Then immediately apply the double-sided tape to the metal surfaces and roll over the tapes with the steel pressure roller. Check for proper adhesion once installed.
6. Applying the sanded tapes – keep sanded tapes warm prior to use. Apply the sanded tapes and roll with pressure roller while still warm. If needed, use a heat gun to blow hot air over them while rolling the pressure roller over them to improve adhesion. Check for proper adhesion once installed.
7. Applying the fabric tapes - keep fabric tapes warm prior to use. Apply the fabric tapes and roll with pressure roller while still warm. If needed, use a heat gun to blow hot air over them while rolling the pressure roller over them to improve adhesion. Check for proper adhesion once installed.
8. Applying the sealant in cold weather (20°F - 50°F) keep the sealant warm prior to use. Apply the sealant while still warm. If needed, use at heat gun to blow hot air to pre-heat the substrates. Check for proper adhesion once installed. Sealant should be allowed to fully cure before exposed to hydrostatic pressures. In very cold weather this may take 14+ days. Therefore, make sure to keep dewatering systems active for a minimum 30 days after sealant installations.

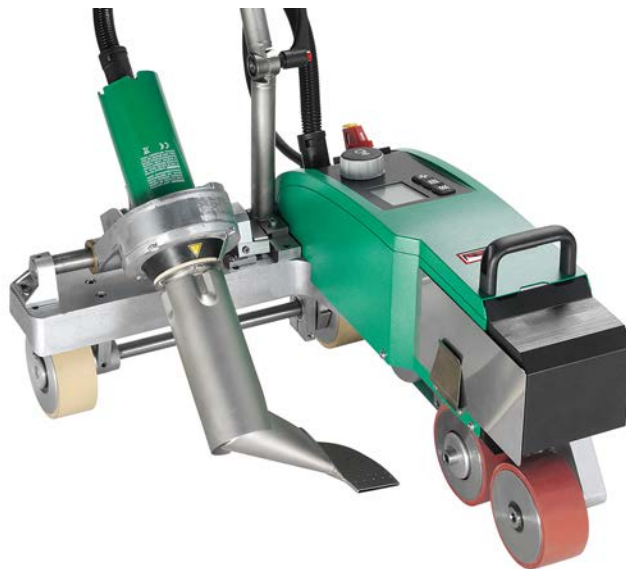

LEISTER HEAT WELDER

## PROTECTING THE MEMBRANE

The membrane is often exposed to environmental and construction traffic, so it is important to protect the membrane during construction until the placement of concrete.

1. Use only water-based marking chalk on top of the installed waterproofing membrane. If other construction marking products are intended to be used, they must be reviewed and approved in writing by the waterproofing manufacturer.
2. Protect membrane during concrete placement from overspray with polyethylene sheeting or other approved means. Remove contamination and cured overspray material from membrane with mechanical means, taking extra care to not damage the waterproofing, prior to further placement of adjoining concrete.
3. Do not permit vehicular traffic on unprotected membrane.
4. Inspect for damage just prior to placement of concrete and make repairs in accordance with manufacturer's recommendations.
5. Product may not be exposed to sunlight for longer than 60 days. If exposure duration is approached and/or exceeded contact manufacturer representative for repair and/or replacement recommendations.

# PROTECTING THE MEMBRANE

The following coverages are based on controlled tests. Actual coverages may vary.

Item/Component	Packaging	Approximate Shipping Weights	Qty per Pallet	VOC
Aussie Skin 560G Membrane 2M (100 Mills)	6.56'x65.6' Roll (430 sqft)	211 lbs (96 kg) / Roll	18 Rolls/Pallet	N/A
Aussie Skin Detail Strip 560G	13.1"x65.6' Roll	30.8 lbs (14 kg) / Roll		N/A
Aussie Skin Double Sided Tape 4"	4"x33' Roll	2.2 lbs / Roll		N/A
Aussie Skin Sanded Tape 4"	3.9"x65.6' Roll	6 lbs / Roll		N/A

L021 Waterproofing Test Results	Test Results	Test Requirements	Test Method
Puncture Resistance	239 Lbf	Min 40 Lbs	ASTM E154
Hydrostatic Pressure Resistance	192 PSI	As Tested	ASTM D751
Lateral Water Migration Resistance	231 feet (71 M) of hydrostatic head pressure	Pass	ASTM D5385 Modified <sup>1</sup>
Resistance to Hydrostatic Head	231 feet (71 M) of hydrostatic head pressure	Pass	ASTM D5385
Adhesion to Concrete and Masonry	10 Pounds	Min 5 Pounds	ASTM D903
Tension & Elongation: Machine Direction	1061 %	Min 250%	ASTM D412
Tension & Elongation: Cross Machine Direction	1050 %	Min 250%	ASTM D412
Accelerated Aging	No considerable reduction in Tension and Elongation of Aged Specimens	Pass. No considerable reduction in either	ASTM G23 & G153
Resistance to Decay (Weight Loss)	0.8%	Max 10%	ASTM E154
Resistance to Decay (Permeance Loss)	0%	Max 10%	ASTM E154
Water Vapor Transmission	0.016 Perms	Max 0.1 Perms	ASTM E96
Water Vapor Transmission after Decay	0.016 Perms	Max 0.1 Perms	ASTM E96
Low temperature flexibility	Unaffected at -29°C	Not Listed	ASTM D1970
Shear strength of joints	14.5 (N/mm)	Not Listed	ASTM D1876
TCE Diffusion Coefficient	1.51E <sup>-12</sup>	Report Results	ASTM 96/96M-16
Benzene Diffusion Coefficient	1.45E <sup>-12</sup>	Report Results	ASTM 96/96M-16
Water Absorption	0.059%	As Tested	ASTM D570

1. Lateral water migration resistance is tested by casting concrete and shot-crete against membrane with a hole and subjecting the membrane to hydrostatic head pressure with water. The test measures the resistance of lateral water migration between the concrete and the membrane. Tests were performed by an independent certified lab. (This test is in addition to the L021 testing requirements)

VOC/Radon Test Results	Test Results	Test Requirements	Test Method
PCE Diffusion Coefficient	6.62E <sup>-13</sup>	Report Results	ASTM 96/96M-16
Radon Diffusion Coefficient D (m <sup>2</sup> /s)	2.2.10 <sup>-12</sup>	Report Results	ISO/TS 11665-13, Method A
Radon (Seam Overlap) Diffusion Coefficient D (m <sup>2</sup> /s)	1.6.10 <sup>-12</sup>	Report Results	ISO/TS 11665-13, Method A

Shot-Crete Test Results	Test Method	Results	Requirements
<b>Installation over Plywood or directly on the Lagging</b>			
Waterproof Integrity of Side (factory) Lap, overlap installed over 2" plywood joint with nails in laps	ASTM D 5385	Pass	No water leakage detected up to 100 PSI
Waterproof Integrity of End (non-factory) Lap, overlap installed over 2" plywood joint	ASTM D 5385	Pass	
Waterproof Integrity of Side (factory) Lap, overlap installed over 2" plywood joint without nails in laps	ASTM D 5385	Pass	No puncture detected
Puncture Integrity at Screw Protrusion, Membrane installed over 1/4" protruding #8 bugle head wood screw	Visual Inspection	Pass	
<b>Installation over Lagging 0.5" EPS Insulation Board (Foam)</b>			
Waterproof Integrity of Side (factory) Lap, overlap installed over EPS Foam Board located over 2" lagging joint with nails in laps	ASTM D 5385	Pass	No water leakage detected up to 100 PSI
Waterproof Integrity of End (non-factory) Lap, overlap installed over EPS Foam Board located over 2" lagging joint	ASTM D 5385	Pass	
Waterproof Integrity of Side (non-factory) Lap, overlap installed over EPS Foam Board located over 2" lagging joint; Joint without nails in laps	ASTM D 5385	Pass	No puncture detected
Puncture Integrity at Nail Protrusion Membrane installed over 1/4" protruding nail with 7/32" dia. head	Visual Inspection	Pass	
<b>Installation over Drain Board</b>			
Waterproof Integrity of Side (factory) Lap, overlap installed over Drain Board located over 2" lagging joint with nails in laps	ASTM D 5385	Pass	No water leakage detected up to 100 PSI
Waterproof Integrity of End (non-factory) Lap, overlap installed over Drain Board located over 2" lagging joint	ASTM D 5385	Pass	
Waterproof Integrity of Side (non-factory) Lap, overlap installed over Drain Board located over 2" lagging joint; Joint without nails in laps	ASTM D 5385	Pass	No puncture detected
Puncture Integrity at Nail Protrusion Membrane installed over 1/4" protruding nail with 7/32" dia. head	Visual Inspection	Pass	

Note: "Test Requirements" as listed in **Los Angeles City Test Protocol L021, Acceptance Criteria for Below-Grade Exterior Damp-Proofing and Waterproofing Materials dated May 2004 And Los Angeles City Shot-Crete Test Protocol dated April 26, 2016.**

\*AVM considers this product to be a VOC barrier based on the above test results. Please contact AVM Technical Services if you have further questions regarding specific VOC's

For a complete list of details in CAD or PDF, please visit our website at [www.avmindustries.com](http://www.avmindustries.com).