



AVM Aussie Mate® 580-AL (60 Mil)

Below Grade Bituminous Sheet Waterproofing Membrane and Methane/VOC/Radon Barrier with UV Stable Aluminum Protection Layer

Product Name

AVM Aussie Mate 580-AL

Manufactured by

AVM Industries, Inc.
8245 Remmet Ave, Canoga Park, CA 91304
888.414.1041 818.888.0050
www.avmindustries.com

Product Description

The **AVM Aussie Mate 580-AL** is a UV stable, heavy duty 60 mil below-grade bituminous sheet waterproofing membrane and methane barrier with aluminum facer. **AVM Aussie Mate 580-AL** exhibits excellent adhesion, elongation and recovery properties. Unlike other sheet membranes, Aussie Mate® 580-AL can be exposed to U.V. up to 180 days.

Approvals

Aussie Mate 580-AL (60 Mils) is approved by LARR (LARR #26138) for use as both a waterproofing membrane and/or methane barrier. This approval is based on tests and analysis in accordance with LADBS Acceptance Criteria LO21 Below-Grade Exterior Damp-Proofing and Waterproofing Materials and L137 Methane Barrier Test Criteria.

Where to Use

Below-Grade: Foundation Walls (Concrete & CMU), Retaining Walls, Basements

Decks & Planters: Plaza Decks, Split-Slab Decks, Planter Boxes

Methane/VOC: Methane and/or VOC barrier for foundation walls and under concrete slabs.

Note: Installation requirements vary based on installation type and project requirements. Refer to Aussie Mate details and Installation Instructions for complete installation requirements.

Warranty

AVM Industries will warrant the installed membrane for a period of five (5) years. Extended warranties are available. For complete warranty details, contact AVM Industries or consult with your applicator.



Delivery, Storage, and Handling

- Delivery of all the **AVM System 580-AL** materials to the job site must be in their original sealed packaging, with manufacturer's name and label intact.
- Handle and store containers in accordance with printed instructions.
- Store at temperatures between 50°F and 90°F. Do not store materials in direct sunlight or where they may be damaged by water or rain.
- Failure to comply with the recommended storage conditions may result in premature deterioration of the product. For specific storage advice, please contact AVM Industries and/or its representatives.
- Keep all materials out of the reach of children.
- If irritation occurs during use, liberally flush affected areas with water. If irritation continues, see a physician immediately.

Project Conditions

- Concrete/block walls: All surfaces to which the **Aussie Mate 580-AL** is applied to must be sound and stable, with an even finish and free from dust, loose debris, grease, curing agents, etc. If necessary, apply a parge coat using AVM Crete 6200.
- The **Aussie Mate 580-AL** may be applied to damp but not waterlogged surfaces (Green Concrete) with AVM Primer 580-SB after 3 days and with Aussie Membrane 500 after 7 days.
- Under slabs over compacted earth or mud slabs: All surfaces to which the **Aussie Mate 580-AL** is applied to must be sound and stable, with an even finish and free from sharp edges, loose debris, oil, grease, etc.
- Typical installation of **Aussie Mate 580-AL** can be performed when ambient and substrate temperatures are 40°F and above. Installations below 40°F are best addressed with Aussie Mate 580 AL cold weather installation instructions. Installations between 25°F - 40°F may be performed if the Aussie mate 580 AL is stored in a heated area until use and the laps are treated accordingly to the cold weather installation procedures. Consult your local Technical Representative for further information. Preparation: Do not apply Aussie mate 580 AL to frozen or wet substrates.

- Do not apply materials if precipitation is imminent.
- Warn personnel against hazards of materials to skin and eyes. Note other hazardous conditions on the job that might require special protective gear and or any other special protective or safety procedures.
- Protect adjacent surfaces which could be damaged during the application procedure.
- This system must not be used to cover Expansion Joints.

System Application

Review the **AVM System 580-AL** Installation Instructions and details prior to installation. On methane jobs, follow methane engineer's details and installation instructions. In some jurisdictions, continuous inspection by a registered deputy inspector certified by AVM Industries and registered in accordance with the requirements specified in LAMC Section 91.1704 for special inspections is required.

Consult with AVM for details.

Quality Control

- Visually inspect all surfaces to ensure full and proper adhesion where applicable, especially at corners, seams, drains, footings and other hard-to-reach areas. On methane jobs, a smoke test or other verification is required.
- All unsatisfactory areas shall be repaired prior to final acceptance.

Protection of Installed Work

Always protect the waterproofing from possible damage. Use AVM Drainage Boards or AVM Approved Protective Panels.

Availability and Cost

Contact AVM Industries or your approved applicator for pricing and availability.

Technical Services

Technical services are available by contacting our offices at: **888.414.1041** or **818.888.0050** or visit **www.avmindustries.com**

System Specifications

Test method: LARR L021

Descriptions	Standard	Requirement	Test Results	Pass/Fail
Water Vapor Permeance	ASTM E 96 water method	≤ 1	0.01 Perms	Pass
Resistance to Decay		Report Results	0.01 Perms	Pass
Samples Tested:	ASTM 154 / ASTM E 96 water method	≤ 10	% Change/Perms: 0%	Pass
Field Area, Factory Lap, Non-Factory Lap		≤ 10	% Weight Loss: 0%	Pass
Tension and Elongation (MD) % Elongation	ASTM D 2523 (Tested Bitumen w/Aluminum)	≥ 25	68 %	Pass
Tension and Elongation (CMD) % Elongation	ASTM D 2523 (Tested Bitumen w/Aluminum)	≥ 25	65 %	Pass
Tension and Elongation (Bitumen only)	ASTM D 2523	≥ 300%	Report Results	Pass
Adhesion to Concrete/Masonry (lbf/in.)	ASTM D 903	≥ 5	Pass	Pass
Puncture Resistance (lbf)	ASTM E 154	≥ 80	125 lbf	Pass
Hydrostatic Pressure resistance max (PSI)	ASTM D 5385	Report Results	100	Pass
Hydrostatic Pressure resistance max (ft of water)	ASTM D 5385	Report Results	231 ft of water	Pass
Hydrostatic Pressure Resistance (ft of water)	ASTM 751	Report Results	171 ft of water	Pass
Low Temperature Flexibility (MD) -20F°	ASTM D 5147	Pass or Fail	Pass	Pass
Low Temperature Flexibility (CMD) -20°	ASTM D 5147	Pass or Fail	Pass	Pass
Tensile Strength	ASTM D 412	Report Results	540 PSI	Pass
Bonded Seam Strength	ASTM D 882	Report Results	46 lbf	Pass
Methane Gas Transmission Rate (mL/day*m ² *atm)	ASTM D4068 Anex A/D412	≤ 40	0.5	Pass
Microorganism Resistance (Soil Burial)	ASTM D4068 Anex A/D412	Pass or Fail	Pass	Pass
Oil Resistance Test	ASTM D543 / D412	Pass or Fail	Pass	Pass
Heat Aging	ASTM D 412	Pass or Fail	Pass	Pass
TCE Diffusion Coefficient	ASTM 96/96M-16	Report Results	4.58e-15m ² /s	Pass
Benzene Diffusion Coefficient	ASTM 96/96M-16	Report Results	6.3e-15m ² /s	Pass
Water Absorption (24h)	ASTM D 570-98	Report Results	.1% by wt.	Pass
Low Temperature Flexibility	ASTM D 1970/D 1970M-20	Pass at -20 deg F	Pass	Pass
Low Temperature Crack Bridging	ASTM C 1305/C 1305M-16	Pass or Fail	Pass	Pass
VOC/Radon Test Results	Standard	Requirement	Test Results	Pass/Fail
PCE Diffusion Coefficient	ASTM 96/96M-16	Report Results	2.26e-15m ² /s	Pass
Radon Diffusion Coefficient D (m ² /s)	ISO/TS 11665-13, Method A	Report Results	<2.5.10 ⁻¹³	Barrier
Radon (Seam Overlap) Diffusion Coefficient D (m ² /s)	ISO/TS 11665-13, Method A	Report Results	6.7.10 ⁻¹³	Barrier

*AVM considers this product to be a VOC barrier based on the above test results.
Please contact AVM Technical Services if you have further questions regarding specific VOCs

Item/Component	Packaging	Approx Shipping Weights	Qty per Pallet	VOC
Aussie Mate 580-AL 60-mil	3.28'x65.6' Roll (215 sq.ft.)	85.0 Pounds (38.7 Kg) / Roll	20 Rolls/Pallet	N/A

For a complete list of details in CAD or PDF, please visit our website at www.avmindustries.com

AVM Industries, Inc.
8245 Remmet Ave, Canoga Park, CA 91304
888.414.1041 818.888.0050

Quality Waterproofing Products



www.avmindustries.com



AVM Aussie Mate® 580-AL (80 Mil)

Below Grade Bituminous Sheet Waterproofing Membrane and Methane/VOC/Radon Barrier with UV Stable Aluminum Protection Layer

Product Name

AVM Aussie Mate 580-AL

Manufactured by

AVM Industries, Inc.
8245 Remmet Ave, Canoga Park, CA 91304
888.414.1041 818.888.0050
www.avmindustries.com

Product Description

The **AVM Aussie Mate 580-AL** is a UV stable, heavy duty 80 mil below-grade bituminous sheet waterproofing membrane and methane barrier with aluminum facer. **AVM Aussie Mate 580-AL** exhibits excellent adhesion, elongation and recovery properties. Unlike other sheet membranes, Aussie Mate® 580-AL can be exposed to U.V. up to 180 days.

Approvals

Aussie Mate 580-AL (80 Mils) is approved by LARR (LARR #26138) for use as a waterproofing membrane and/or methane barrier in both the City and the County of Los Angeles. This approval is based on tests and analysis in accordance with LADBS Acceptance Criteria L021 Below-Grade Exterior Damp-Proofing and Waterproofing Materials and L137 Methane Barrier Test Criteria.

Where to Use

Below-Grade: Foundation Walls (Concrete & CMU), Retaining Walls, Basements

Decks & Planters: Plaza Decks, Split-Slab Decks, Planter Boxes

Methane/VOC: Methane and/or VOC barrier for foundation walls and under concrete slabs.

Note: Installation requirements vary based on installation type and project requirements. Refer to Aussie Mate details and Installation Instructions for complete installation requirements.

Warranty

AVM Industries will warrant the installed membrane for a period of five (5) years. Extended warranties are available. For complete warranty details, contact AVM Industries or consult with your applicator.



Delivery, Storage, and Handling

- Delivery of all the **AVM System 580-AL** materials to the job site must be in their original sealed packaging, with manufacturer's name and label intact.
- Handle and store containers in accordance with printed instructions.
- Store at temperatures between 50°F and 90°F. Do not store materials in direct sunlight or where they may be damaged by water or rain.
- Failure to comply with the recommended storage conditions may result in premature deterioration of the product. For specific storage advice, please contact AVM Industries and/or its representatives.
- Keep all materials out of the reach of children.
- If irritation occurs during use, liberally flush affected areas with water. If irritation continues, see a physician immediately.

Project Conditions

- Concrete/block walls: All surfaces to which the **Aussie Mate 580-AL** is applied to must be sound and stable, with an even finish and free from dust, loose debris, grease, curing agents, etc. If necessary, apply a parge coat using AVM Crete 6200.
- The **Aussie Mate 580-AL** may be applied to damp but not waterlogged surfaces (Green Concrete) with AVM Primer 580-SB after 3 days and with Aussie Membrane 500 after 7 days.
- Under slabs over compacted earth or mud slabs: All surfaces to which the **Aussie Mate 580-AL** is applied to must be sound and stable, with an even finish and free from sharp edges, loose debris, oil, grease, etc.
- Typical installation of **Aussie Mate 580-AL** can be performed when ambient and substrate temperatures are 40°F and above. Installations below 40°F are best addressed with Aussie Mate 580 AL cold weather installation instructions. Installations between 25°F - 40°F may be performed if the Aussie mate 580 AL is stored in a heated area until use and the laps are treated accordingly to the cold weather installation procedures. Consult your local Technical Representative for further information. Preparation: Do not apply Aussie mate 580 AL to frozen or wet substrates.

- Do not apply materials if precipitation is imminent.
- Warn personnel against hazards of materials to skin and eyes. Note other hazardous conditions on the job that might require special protective gear and or any other special protective or safety procedures.
- Protect adjacent surfaces which could be damaged during the application procedure.
- This system must not be used to cover Expansion Joints.

System Application

Review the **AVM System 580-AL** Installation Instructions and details prior to installation. On methane jobs, follow methane engineer's details and installation instructions. In some jurisdictions, continuous inspection by a registered deputy inspector certified by AVM Industries and registered in accordance with the requirements specified in LAMC Section 91.1704 for special inspections is required.

Consult with AVM for details.

Quality Control

- Visually inspect all surfaces to ensure full and proper adhesion where applicable, especially at corners, seams, drains, footings and other hard-to-reach areas. On methane jobs, a smoke test or other verification is required.
- All unsatisfactory areas shall be repaired prior to final acceptance.

Protection of Installed Work

Always protect the waterproofing from possible damage. Use AVM Drainage Boards or AVM Approved Protective Panels.

Availability and Cost

Contact AVM Industries or your approved applicator for pricing and availability.

Technical Services

Technical services are available by contacting our offices at: **888.414.1041** or **818.888.0050** or visit **www.avmindustries.com**

System Specifications

Test method: LARR L021

Descriptions	Standard	Requirement	Test Results	Pass/Fail
Water Vapor Permeance	ASTM E 96 water method	≤ 1	0.01 Perms	Pass
Resistance to Decay		Report Results	0.01 Perms	Pass
Samples Tested:	ASTM 154 / ASTM E 96 water method	≤ 10	% Change/Perms: 0%	Pass
Field Area, Factory Lap, Non-Factory Lap		≤ 10	% Weight Loss: 0%	Pass
Tension and Elongation (MD) % Elongation	ASTM D 2523 (Tested Bitumen w/Aluminum)	≥ 25	68 %	Pass
Tension and Elongation (CMD) % Elongation	ASTM D 2523 (Tested Bitumen w/Aluminum)	≥ 25	65 %	Pass
Tension and Elongation (Bitumen only)	ASTM D 2523	≥ 300%	Report Results	Pass
Adhesion to Concrete/Masonry (lbf/in.)	ASTM D 903	≥ 5	Pass	Pass
Puncture Resistance (lbf)	ASTM E 154	≥ 80	125 lbf	Pass
Hydrostatic Pressure resistance max (PSI)	ASTM D 5385	Report Results	100	Pass
Hydrostatic Pressure resistance max (ft of water)	ASTM D 5385	Report Results	231 ft of water	Pass
Hydrostatic Pressure Resistance (ft of water)	ASTM 751	Report Results	171 ft of water	Pass
Low Temperature Flexibility (MD) -20F°	ASTM D 5147	Pass or Fail	Pass	Pass
Low Temperature Flexibility (CMD) -20°	ASTM D 5147	Pass or Fail	Pass	Pass
Tensile Strength	ASTM D 412	Report Results	540 PSI	Pass
Bonded Seam Strength	ASTM D 882	Report Results	46 lbf	Pass
Methane Gas Transmission Rate (mL/day*m ² *atm)	ASTM D4068 Anex A/D412	≤ 40	0.5	Pass
Microorganism Resistance (Soil Burial)	ASTM D4068 Anex A/D412	Pass or Fail	Pass	Pass
Oil Resistance Test	ASTM D543 / D412	Pass or Fail	Pass	Pass
Heat Aging	ASTM D 412	Pass or Fail	Pass	Pass
TCE Diffusion Coefficient	ASTM 96/96M-16	Report Results	4.58e-15m ² /s	Pass
Benzene Diffusion Coefficient	ASTM 96/96M-16	Report Results	6.3e-15m ² /s	Pass
Water Absorption (24h)	ASTM D 570-98	Report Results	.1% by wt.	Pass
Low Temperature Flexibility	ASTM D 1970/D 1970M-20	Pass at -20 deg F	Pass	Pass
Low Temperature Crack Bridging	ASTM C 1305/C 1305M-16	Pass or Fail	Pass	Pass
VOC/Radon Test Results	Standard	Requirement	Test Results	Pass/Fail
PCE Diffusion Coefficient	ASTM 96/96M-16	Report Results	2.26e-15m ² /s	Pass
Radon Diffusion Coefficient D (m ² /s)	ISO/TS 11665-13, Method A	Report Results	<2.5.10 ⁻¹³	Barrier
Radon (Seam Overlap) Diffusion Coefficient D (m ² /s)	ISO/TS 11665-13, Method A	Report Results	3.4.10 ⁻¹³	Barrier

*AVM considers this product to be a VOC barrier based on the above test results.
Please contact AVM Technical Services if you have further questions regarding specific VOCs

Item/Component	Packaging	Approx Shipping Weights	Qty per Pallet	VOC
Aussie Mate 580-AL 80-mil	3.28'x65.6' Roll (215 sq.ft.)	123.2 Pounds (56 Kg) / Roll	16 Rolls/Pallet	N/A

For a complete list of details in CAD or PDF, please visit our website at www.avmindustries.com

AVM Industries, Inc.
8245 Remmet Ave, Canoga Park, CA 91304
888.414.1041 818.888.0050

Quality Waterproofing Products



www.avmindustries.com



AVM Primer 580-SB-HV (HIGH VOC) Rapid Cure, General Purpose Primer for Aussie Mate Below Grade Bituminous Waterproofing Sheet Membranes

Product Name

AVM Primer 580-SB

Manufactured by

AVM Industries, Inc.
8245 Remmet Ave, Canoga Park, CA 91304
888.414.1041 818.888.0050
www.avmindustries.com

Product Description

AVM Primer 580-SB-HV is a rapid cure primer composed of synthetic polymers, adhesive enhancing resins and solvents. It is designed to enhance the adhesion of self-adhesive membranes on various substrates including porous surfaces.

Where to Use

AVM Primer 580-SB-HV is used with the Aussie Mate 580-AL and Aussie Mate 580-PL sheet membranes. **AVM Primer 580-SB-HV** is suitable for both vertical and horizontal applications. It is formulated to enhance the bond between the Aussie Mate 580 membranes and various substrates, including concrete, CMU, brick, Dens Deck, gypsum and metal.

Limitations

Do not use Aussie **Primer 580-SB-HV** over ponding or standing water, snow or ice. Use in well-ventilated areas and avoid breathing in vapors. Do not apply Aussie 580-SB-HV when rain is imminent. Do not allow Aussie Mate 580-SB-HV to puddle, as it will extend the cure time. Avoid using the Aussie 580-SB-HV on wood substrates.

Warranty

AVM's standard 1-year material warranty applies. This product is sold as part of a waterproofing system. Please refer to those system's warranties for additional warranty information.

Delivery, Storage, and Handling

- Delivery of the **AVM Primer 580-SB-HV** to the job site must be in its original sealed packaging, with manufacturer's name and label intact.
- Handle and store containers in accordance with printed instructions. Flammable. Store in a well-ventilated area, away from direct sunlight and open flame.
- Shelf Life: 60 months in un-opened containers when protected from UV light and stored in dry conditions at temperatures between 40°F and 90°F.
- Failure to comply with the recommended storage conditions may result in premature deterioration of the product.
- Keep all materials out of the reach of children.
- If irritation occurs during use, liberally flush affected areas with water. If irritation continues, see a physician immediately.

Project Conditions

- All surfaces to which the **AVM Primer 580-SB-HV** is applied to must be sound, stable, dry, with an even finish and free from dust, loose debris, grease, curing agents, etc. Concrete surface profile (CSP) should be 6 or smoother. If necessary, apply a parge coat using AVM Crete 6200. Do not apply to frozen substrates.
- Structural concrete must be cured for at least 72 hours. Lightweight structural concrete must be cured for at least 14 days. Install membrane over smooth concrete blocks (CMU). If the blocks are rough or the mortar joints are tooled, parge the surfaces with AVM Crete 6200 to make them smooth. Allow parge coat to dry before the substrate is primed and the membrane is installed.

System Application

Read the **AVM Primer 580-SB-HV** Installation Instructions Prior to Installation. Application instructions vary based on type of application and the type of surfaces it's being applied to.

- Ready to use - do not dilute.
- Solvent Based - use with adequate ventilation.
- Mixing is necessary before use.

1. Apply materials in dry weather, when ambient temperatures are between 40°F and 100°F. Do not leave exposed to U.V. Cover with membrane as soon as possible.
2. Apply **AVM Primer 580-SB-HV** at the rate noted on the below chart based on substrate type by either brush or roller. Do not pour the AVM 580-SB-HV directly onto substrates.
3. Application of the **AVM Primer 580-SB-HV** should be limited to an area that will be covered by a waterproofing membrane the same day. If the application area is not covered by a waterproofing membrane the same day, **AVM Primer 580-SB-HV** must be reapplied before installation of the waterproofing membrane.
4. Allow **AVM Primer 580-SB-HV** to completely dry before applying the membrane. To test if the primer is set press your forefinger on to the primed surface. When you lift your finger, there should be no strings of polymer that pull up with your finger. High humidity, cooler temperatures and porous substrates will need additional drying times. Standard drying time is 15-60 minutes, depending on temperature and quantity applied.
5. Warn personnel against hazards of materials to skin and eyes. Note other hazardous conditions on the job that might require special protective gear and or any other special protective or safety procedures.
6. Protect adjacent surfaces which could be damaged during the application procedure.

Quality Control

- a. Visually inspect all surfaces to ensure full and proper adhesion, especially at corners, seams, drains, footings and other hard-to-reach areas.
- b. All unsatisfactory areas shall be repaired prior to final acceptance.

Protection of Installed Work

Always protect the waterproofing from possible damage. Use AVM Drainage Boards or AVM Approved Protective Panels.

Availability and Cost

Contact AVM Industries or your approved applicator for pricing and availability.

Technical Services

Technical services are available by contacting our offices at: **888.414.1041** or **818.888.0050** or visit **www.avmindustries.com**

System Specifications

Item/Component	Packaging	Approx Shipping Weights	Qty per Pallet	Coverages	VOC
AVM Primer 580-SB-HV	1 gal / 5 gal buckets	-33 Pounds (-15 kg)	36	-1250 Lbs (-568 kg)	146 g/L

Properties	Test Result
Color	Copper
Specific Gravity at 25°C (77°F)	0.79 kg/L
Solids by Weight	24%
Viscosity @ 77°F	200 cp
Drying Time	15-60 minutes, depending on temperature and quantity applied
VOC Content	500 g/l

Coverage Rates

Substrate Type	Coverage
Porous	80 - 133 sq.ft / gal
Non-porous	160 - 400 sq.ft / gal

Actual coverages may vary based on substrate conditions and other factors.

For a complete list of details in CAD or PDF, please visit our website at www.avmindustries.com



AVM Primer 580-SB-LV (Low Voc) Rapid Cure, General Purpose Primer for Aussie Mate Below Grade Bituminous Waterproofing Sheet Membranes

Product Name

AVM Primer 580-SB

Manufactured by

AVM Industries, Inc.
8245 Remmet Ave, Canoga Park, CA 91304
888.414.1041 818.888.0050
www.avmindustries.com

Product Description

AVM Primer 580-SB-LV is a rapid cure primer composed of synthetic polymers, adhesive enhancing resins and solvents. It is designed to enhance the adhesion of self-adhesive membranes on various substrates including porous surfaces.

Where to Use

AVM Primer 580-SB-LV is used with the Aussie Mate 580-AL and Aussie Mate 580-PL sheet membranes. **AVM Primer 580-SB-LV** is suitable for both vertical and horizontal applications. It is formulated to enhance the bond between the Aussie Mate 580 membranes and various substrates, including concrete, CMU, brick, Dens Deck, gypsum and metal.

Limitations

Do not use Aussie **Primer 580-SB-LV** over ponding or standing water, snow or ice. Use in well-ventilated areas and avoid breathing in vapors. Do not apply Aussie 580-SB-LV when rain is imminent. Do not allow Aussie Mate 580-SB-LV to puddle, as it will extend the cure time. Avoid using the Aussie 580-SB-LV on wood substrates.

Warranty

AVM's standard 1-year material warranty applies. This product is sold as part of a waterproofing system. Please refer to those system's warranties for additional warranty information.

Delivery, Storage, and Handling

- Delivery of the **AVM Primer 580-SB-LV** to the job site must be in its original sealed packaging, with manufacturer's name and label intact.
- Handle and store containers in accordance with printed instructions. Flammable. Store in a well-ventilated area, away from direct sunlight and open flame.
- Shelf Life: 60 months in un-opened containers when protected from UV light and stored in dry conditions at temperatures between 40°F and 90°F.
- Failure to comply with the recommended storage conditions may result in premature deterioration of the product.
- Keep all materials out of the reach of children.
- If irritation occurs during use, liberally flush affected areas with water. If irritation continues, see a physician immediately.

Project Conditions

- All surfaces to which the **AVM Primer 580-SB-LV** is applied to must be sound, stable, dry, with an even finish and free from dust, loose debris, grease, curing agents, etc. Concrete surface profile (CSP) should be 6 or smoother. If necessary, apply a parge coat using AVM Crete 6200. Do not apply to frozen substrates.
- Structural concrete must be cured for at least 72 hours. Lightweight structural concrete must be cured for at least 14 days. Install membrane over smooth concrete blocks (CMU). If the blocks are rough or the mortar joints are tooled, parge the surfaces with AVM Crete 6200 to make them smooth. Allow parge coat to dry before the substrate is primed and the membrane is installed.

System Application

Read the **AVM Primer 580-SB-LV** Installation Instructions Prior to Installation. Application instructions vary based on type of application and the type of surfaces it's being applied to.

- Ready to use – do not dilute.
- Solvent Based – use with adequate ventilation.
- Mixing is necessary before use.

1. Apply materials in dry weather, when ambient temperatures are between 40°F and 100°F. Do not leave exposed to U.V. Cover with membrane as soon as possible.
2. Apply **AVM Primer 580-SB-LV** at the rate noted on the below chart based on substrate type by either brush or roller. Do not pour the AVM 580-SB-LV directly onto substrates.
3. Application of the **AVM Primer 580-SB-LV** should be limited to an area that will be covered by a waterproofing membrane the same day. If the application area is not covered by a waterproofing membrane the same day, **AVM Primer 580-SB-LV** must be reapplied before installation of the waterproofing membrane.
4. Allow **AVM Primer 580-SB-LV** to completely dry before applying the membrane. To test if the primer is set press your forefinger on to the primed surface. When you lift your finger, there should be no strings of polymer that pull up with your finger. High humidity, cooler temperatures and porous substrates will need additional drying times. Standard drying time is 30-90 minutes, depending on temperature and quantity applied.
5. Warn personnel against hazards of materials to skin and eyes. Note other hazardous conditions on the job that might require special protective gear and or any other special protective or safety procedures.
6. Protect adjacent surfaces which could be damaged during the application procedure.

Quality Control

- a. Visually inspect all surfaces to ensure full and proper adhesion, especially at corners, seams, drains, footings and other hard-to-reach areas.
- b. All unsatisfactory areas shall be repaired prior to final acceptance.

Protection of Installed Work

Always protect the waterproofing from possible damage. Use AVM Drainage Boards or AVM Approved Protective Panels.

Availability and Cost

Contact AVM Industries or your approved applicator for pricing and availability.

Technical Services

Technical services are available by contacting our offices at: **888.414.1041** or **818.888.0050** or visit **www.avmindustries.com**

System Specifications

Item/Component	Packaging	Approx Shipping Weights	Qty per Pallet	Coverages	VOC
AVM Primer 580-SB-LV	1 gal / 5 gal buckets	-39 Pounds (-17.8 kg)	36	-1470 Lbs (-668 kg)	146 g/L

Properties	Test Result
Color	Copper
Specific Gravity at 25°C (77°F)	0.94 kg/L
Solids by Weight	49%
Viscosity @ 77°F	300-600 cp
Drying Time	30-90 minutes, depending on temperature and quantity applied
VOC Content	240 g/l

Coverage Rates

Substrate Type	Coverage
Porous	82 - 165 sq.ft / gal
Non-porous	132 - 331 sq.ft / gal

Actual coverages may vary based on substrate conditions and other factors.

For a complete list of details in CAD or PDF, please visit our website at www.avmindustries.com



Aussie Seal® M

Marine-Grade Sealant/Adhesive

Thermal and Moisture Protection

Sections 071000

Fluid Applied Waterproofing

Product Name

Aussie Seal® M

Manufactured by

AVM Industries, Inc.

8245 Remmet Ave, Canoga Park, CA 91304

888.414.1041 818.888.0050

www.avmindustries.com

Product Description

Aussie Seal® M is an extra heavy duty, easy to install, Marine-Grade moisture cure polyether Sealant / Adhesive formulated for applications above the water line or after curing below the water line and in areas where solvent based materials are not tolerated. **Aussie Seal® M** is solvent free and contains no isocyanates. It will not shrink upon curing, will not discolor when exposed to U.V., and will not "out-gas" or bubble on damp surfaces as urethane sealants often do. The sealant has resilient elastomeric properties and excellent adhesion to most substrates. It can be used effectively in many difficult conditions, cures rapidly in dry or wet climates, (including under freshly poured concrete) and low temperatures compared to urethane based materials.

Where to Use

As a stand-alone sealant or adhesive or in conjunction with many types of waterproofing systems including Below grade bituminous and polyurethane membranes, HDPE Membranes, Acrylic and Urethane Deck Coatings, etc. **Aussie Seal® M** was specifically designed to be used with AVM's waterproofing systems including AVM System 100, Elasto Fiberdeck®, AVM System 100 Forevercoat®, Aussie Membrane® 500, Aussie Membrane® 502, Aussie Skin® 550, Aussie Hot Rubber 570, Aussie Mate® 580-AL, AVM System 650, AVM System 680, AVM System 700 and AVM System 750.

Aussie Seal® M may be applied to many substrates including galvanized and bonarized metal, steel, aluminum, copper, cast iron, PVC and ABS pipes, acrylic coatings, polyurethane coatings, HDPE (Aussie Skin sand side and HDPE side), bitumen (Aussie Membranes 500/502), to the aluminum side of Aussie Mate® 580-AL, wood, glass and many other common substrates.

Substrate Preparation:

Bonding surfaces must be clean, dry and free of oxidation, mill oils, wax, and release agents that may interfere with adhesion. Dry and fully cure painted surfaces before bonding. Alcohol and ammonia water are effective cleaners for surface preparation. Abraded or irregular surfaces are acceptable bonding surfaces but must be clean and sound.

Application Method:

Aussie Seal® M is a gun grade material that is applied from caulking guns, high viscosity pump guns, or automated bead application equipment. This product sets rapidly upon exposure to moisture. Open containers must be quickly protected from atmospheric moisture. Mask off areas that must be protected from adhesives. Allow the assembly to cure for 30 minutes to an hour before handling or machining. When bonding two impermeable materials, brief separation and reassembly of the bonding surfaces to expose the adhesive to atmospheric moisture will often accelerate the cure. In extremely dry environments, local humidification may be needed to initiate curing. Low temperature will retard the cure reaction and heat will accelerate the cure reaction. Optimum application temperatures are between 60°F to 100°F (16°C to 38°C). Sealant can be applied at temperatures as low as 20°F (-7°C). For applications below 20°F, refer to cold weather application procedures below.

Aussie Seal® M is a moisture cure sealant that in most cases can be installed in wet or damp environments. Typical cure time is 12-24 hours depending on thickness of sealant and environmental conditions. Do not subject the un-cured sealant to hydrostatic conditions. However, in some cases, it may be allowed. Contact your AVM rep for details.

Cold Weather Application (20°F - 50°F) - Keep the sealant warm prior to use. (Store in a warm room or tent at 70°F) Apply the sealant while still warm. If needed, use a heat gun to blow hot air to pre-heat the substrates. Check for proper adhesion once installed.. In very cold weather this may take 14+ days.

If your project requirements do not conform to the above requirements, please contact your local AVM rep for further instructions.

Warranty

AVM warrants **Aussie Seal® M**'s performance, provided it is properly stored and applied within 1 year. If **Aussie Seal® M** is proved to be defective, return remaining product and purchase receipt for refund or replacement of product exclusive of labor or cost of labor. This is the sole and exclusive remedy for defects or failure of this product. User must read and follow the direction of the current Technical Data Sheet and SDS prior to product use. User determines suitability of product for intended use and assumes all risks. AVM shall not be liable for damages (including consequential or incidental damages) in excess of the purchase price, except where such exclusion or limitation is prohibited by state law. **This warranty is in lieu of all other warranties, written or oral, statutory, express or implied including any warranty of merchantability or fitness for a particular purpose;** except for the above express warranty given by AVM, the product is sold with all faults. **AVM shall not be responsible for the use of this product in a manner to infringe on any patent or any other intellectual property rights held by others.** For additional warranty claim information, call 818-888-0050.

Delivery, Storage, and Handling

- a. Delivery of all the **Aussie Seal® M** materials to the job site must be in their original sealed containers, with manufacturer's name and label intact.
- b. Shelf Life: Twelve months from date of manufacture when stored at 70°F / 21°C with 50% relative humidity. High temperature and high relative humidity may significantly reduce shelf life. Pails have a shelf life of six months.
- c. Store at temperatures between 50°F and 75°F. Do not store materials in direct sunlight or where they may be damaged by water or rain.
- d. Failure to comply with the recommended storage conditions may result in premature deterioration of the product.
- e. Keep all materials out of the reach of children.

Quality Control

- a. Visually inspect all coated surfaces to ensure a full and proper application, especially at penetrations, seams, corners, drainage footings and other hard-to-reach areas.
- b. All unsatisfactory areas shall be repaired prior to final acceptance.

Availability and Cost

Contact AVM Industries or your approved applicator for pricing and availability.

Technical Services

Technical services are available by contacting our offices at: **888.414.1041** or **818.888.0050** or visit **www.avmindustries.com**

The following coverages are based on controlled tests. Actual coverages may vary.

Technical Information		
Viscosity	1,200,000 +/- 400,000 cp at 72°F 22°C)	Brookfield RVF, TF spindle, 4 RPM
Density	11.8 +/- 0.2 lbs per gallon	ASTM D1475
Tack Free Time	20 +/- 10 min	45 +/- 5 % R.H.
Elongation at Break	275 - 325%	ASTM D412
Tensil Strength	325 - 375 psi	ASTM D412
Hardness Shore A	38 - 42	ASTM C661
Low Temp. Flex	-10°F (-23°C) Pass1/4 inch mandrel	ASTM D816
VOC Content	Less than 15 g/l	ASTM D2369
Shrinkage	No visible shrinkage after 14 days	
Service Temp.	-40°F to 200°F / -40°C to 93°C	

20 oz Sausages, 5 gallon pails and 50 gallon drums are available by special order. Standard color is gray. White or Black are available by special order.

All properties described in this document are derived from testing conducted in laboratory conditions. Properties and performance will vary depending on environmental conditions and application technique. Test and evaluate to determine appropriate usage. Visit www.avmindustries.com for the Safety Data Sheet and pertinent documentation.

For a complete list of details in CAD or PDF, please visit our website at www.avmindustries.com.

AVM Industries, Inc.
8245 Remmet Ave, Canoga Park, CA 91304
888.414.1041 818.888.0050

Quality Waterproofing Products



www.avmindustries.com

AVM Aussie Swell® Red (The Red Waterstop) Expandable Waterstop

AVM System 940, Aussie Swell® Red, Expandable Bentonite Waterstop

Sections Section 031100 / 031500 / 031513.16
Expandable Waterstop**Product Name**

AVM Aussie Swell® Red

Manufactured byAVM Industries, Inc.
8245 Remmet Ave, Canoga Park, CA 91304
888.414.1041 818.888.0050
www.avmindustries.com**Product Description**

Aussie Swell Red is a hydrophilic strip waterstop and that is a formulated blend of sodium bentonite & butyl rubber. Aussie Swell Red is an active waterstop which reacts with water to seal construction joints within concrete. The seal resists hydrostatic pressure, stopping the passage of water through the joint. Due to the sodium bentonite content, on contact with water, Aussie Swell Red will swell (expand) within its confinement, self-injecting into localized voids & minor fissures. Aussie Swell Red is an active waterstop designed to replace passive PVC/Rubber waterbars, without the need for pre-formed intersections, split forming or seam welding.

Where to Use

Aussie Swell Red can be applied to concrete, steel or pipe (PVC). Coil ends are butt jointed (not overlapped) to form a continuous waterstop. Use in concrete joints, pipe penetrations, wall-to-floor joints, irregular surfaces, etc.

Advantages

- Non-dimensional swell allows complete injection to surrounding voids.
- Conformable – can be applied to a range of irregular substrates.
- Resists in excess of 6 bar (60m) hydrostatic pressure.
- Swells many times more than its dry volume to form impenetrable gel.
- Simple butt jointing on site application.
- Reproducible swell after wet-dry cycle.
- Unaffected by freeze/thaw cycling.

**Limitations**

- Aussie Swell Red is not designed to function in movement/expansion joints.
- Aussie Swell Red is designed for minimum 2000 PSI reinforced concrete. Furthermore, it requires confinement and it must be covered by minimum 3" concrete on all sides.
- Aussie Swell Red should not be subjected to submersion or remain in contact with water prior to concrete pour. If the product exhibits any considerable swell prior to concrete pour it must be replaced.
- In conditions where sever ground water or chemical contamination exists or is expected consult manufacture for approval

Warranty

AVM's Standard 5-year material warranty applies. Contact AVM for warranty information.

Delivery, Storage, and Handling

- a. Delivery of all the Aussie Swell Red® components to the job site must be in their original sealed packaging, with manufacturer's name and label intact.
- b. Store indoors in a cool DRY place (away from heat or moisture) at temperatures between 50°F and 90°F. Do not store materials in direct sunlight or where they may be damaged by water or rain.
- c. Keep all materials out of the reach of children.

Project Conditions

- a. Do not apply materials at temperatures below 20°F, or above 110°F if applying in direct sun light.

System Application

Use AVM's Aussie Seal M as the adhesive to install the Aussie Swell Red waterstop. Refer to the Aussie Swell Red Installation instructions, for detailed Installation procedures.

Quality Control

Visually inspect the installed Aussie Swell Red product to ensure it is properly adhered to substrate and that it has not been subjected to premature hydration. Consult with manufacturer if you have any questions.

Protection of Installed Work

The completed Aussie Swell Red system shall be protected until concrete is poured over it. Maximum exposure to UV is 30 days.

Availability and Cost

Contact an AVM authorized distributor for availability and pricing.

Technical Services

Technical services are available by contacting our offices at: **888.414.1041** or **818.888.0050** or visit **www.avmindustries.com**

System Specifications

See next page.

The following coverages are based on controlled tests. Actual coverages may vary.

Item/Component	Item Size	Qty / Box	Qty per Pallet	Weights			VOC
				Each	Box	Pallet	
Aussie Swell Red Coil	16.4 LF (5M)	6 Coils	216 Coils (36 Boxes)	8.58 lb	53.7 lbs	1937 lbs	N/A
Aussie Seal M Cartridge	10.1 oz (300 ml)	12 Cartridges	105 Boxes / 1260 Cartridges	1.0 lb	12.2 lbs	1281 lbs	15 g/l
Aussie Seal M Sausage	20 oz (600 ml)	12 Sausages	45 Boxes / 540 Sausages	2.0 lb	24.4 lbs	1098 lbs	15 g/l

For a complete list of details in CAD or PDF, please visit our website at www.avmindustries.com.

AVM Industries, Inc.
 8245 Remmet Ave, Canoga Park, CA 91304
 888.414.1041 818.888.0050

Quality Waterproofing Products



www.avmindustries.com



AVM Drain Board 6000/6020

Prefabricated Drainage Composites

Sections 334600 / 334613 / 334616 /
334619 / 334633

Prefabricated Drainage Composites

Product Name

AVM Drain Board 6000/6020

Manufactured by

AVM Industries, Inc.
8245 Remmet Ave, Canoga Park, CA 91304
888.414.1041 818.888.0050
www.avmindustries.com

Product Description

Provides protection for waterproofing systems and managing subsurface water around building foundations. Soil backfill is retained while allowing water to pass into the drainage system providing hydrostatic relief. Collected water is then conveyed to AVM Bottom Drain 6" or AVM Bottom Drain 12", or other collection systems.

Consists of an impermeable polymeric sheet cusped under heat and pressure to form a high flow dimpled drainage core. The core is then bonded to a layer of nonwoven filter fabric. The filter fabric retains soil or sand particles as well as freshly placed concrete or grout, allowing filtered water to pass into the drainage core.

Where to Use

AVM Drain Board 6000/6200 is ideal for use with foundation walls, retaining walls, planters, roof gardens, bridge abutments, and under slabs.

AVM Drain Board 6000 / 6020

Maintains a very high flow rate while providing a higher compressive strength for greater depths. A very popular choice for vertical and horizontal single sided drainage applications. Moderate duty.

AVM Drain Board 6000XL / 6020XL*

Designed for extra heavy duty vertical and horizontal applications that demand greater compressive strength and improved filtration for challenging soil conditions. Heavier duty drain core & fabric.

* 6020 and 6020XL are identical to 6000 and 600XL with the addition of a membrane protective film on the back side.

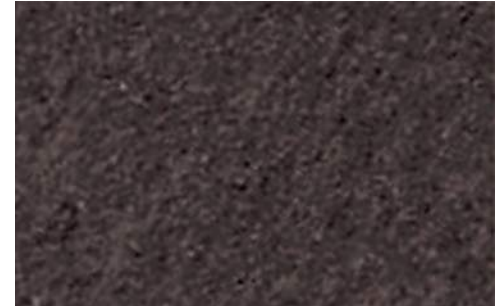

Delivery, Storage, and Handling

- a. Packing and shipping: Provide materials in original unopened containers with manufacturer's labels intact and legible.
- b. Acceptance at site:
 1. Unload materials: check for damage.
 2. Damaged materials determined by visual inspection will not be accepted.
 3. Remove rejected materials from site immediately.
- b. Storage and protection:
 1. Store materials in dry area in manufacturer's protective packaging with labels and installation instructions intact.
 2. Store materials under cover, off ground; protect from sunlight.
 3. Transmissivity or Flow Q with hydraulic gradient of 1 with confining stress indicated in MANUFACTURED UNITS Article in accord with ASTM D4716-01

Project Conditions

1. All surfaces to which the Drainage Boards are applied to must be clean, sound and stable enough to properly attach and hold onto the drain boards being installed.
2. Warn personnel against hazards of working with this product. Sharp edges, weight, etc. Note other hazardous conditions on the job that might require special attention or extra protective gear and or any other special protective or safety procedures.
3. Protect adjacent surfaces which could be damaged during the application procedure.

Inspection of Substrates

1. Verify 1% slope to underslab collection pipes or site water drainage system at underslab drainage system location substrate.
2. Examine conditions and substrates where products specified in this section are installed; submit written notification of unacceptable conditions or substrates.

System Application

Refer to installation instructions.

Quality Control

- a. Visually inspect all drain board surfaces to ensure a full and proper drain board system application, especially at corners, drainage footings and other hard-to-reach areas.
- b. All unsatisfactory areas shall be repaired prior to final acceptance.

Protection of Installed Work

Always protect the waterproofing and drainage system until fully covered with dirt, concrete, shot-crete, etc.

Availability and Cost

Contact AVM Industries or your approved applicator for pricing and availability.

Technical Services

Technical services are available by contacting our offices at: **888.414.1041** or **818.888.0050** or visit **www.avmindustries.com**

System Specifications

See next page.

Physical Properties

Core	6000/6020	6000XL/6020XL
Compressive Strength (ASTM D-1621)	15,000 psf (719 kNm ²)	16,500 psf (790 kNm ²)
Thickness (ASTM D-1777)	.40" (10.16 mm)	.40" (10.16 mm)
Flow (Hydraulic gradient = 1) (ASTM D-4716)	21 g/min/ft (260 L/min/m)	21 g/min/ft (260 L/min/m)

Fabric	6000/6020	6000XL/6020XL
Flow (ASTM D-4491)	140 gal/min/ft ²² (5704 L/min/m ²)	110 gal/min/ft ² (4482 L/min/m ²)
Puncture (ASTM D-4833)	65 lbs. (.30 kN)	95 lbs. (.42 kN)
AOS (EOS)	70 U.S. Sieve (.212 mm)	70 U.S. Sieve (.212 mm)
Grab Tensile (ASTM D-4632)	100 lbs. (.45 kN)	160 lbs. (.71 kN)

General Characteristics					
Roll Length	Roll Width	Roll Weight (approx. lbs.)			
		6000	6020	6000XL	6020XL
50 ft. (15.24 m)	4.0 ft. (1.22 m)	39.0	40.5	45.0	46.5
50 ft. (15.24 m)	6.5 ft. (1.98 m)	63.0	65.5	73.0	75.5
50 ft. (15.24 m)	8.0 ft. (2.43 m)	82.0	85.0	95.0	98.0

Notes:

AVM Drain Board 6000 in 4' and 6.5' widths are stocked items.

All other drain board versions are "Special Order" items. Allow 2 weeks lead time for special order items.

For pricing and availability of special order items, please contact AVM Industries or your local distributor.

For a complete list of details in CAD or PDF, please visit our website at www.avmindustries.com.

AVM Industries, Inc.
8245 Remmet Ave, Canoga Park, CA 91304
888.414.1041 818.888.0050

Quality Waterproofing Products



www.avmindustries.com



TECH DATA SHEET

Sections - 334600 / 334616.16 / 334619.16 / 334623.19

AVM Drain Board 9000/9020/9080

Prefabricated Drainage Composites

Sections 334600 / 334616.16 /
334619.16 / 334623.19

Prefabricated Drainage Composites

Product Name

AVM Drain Board 9000 / 9020 / 9080

Manufactured by

AVM Industries, Inc.
8245 Remmet Ave, Canoga Park, CA 91304
888.414.1041 818.888.0050
www.avmindustries.com

Product Description

Drain Board for Horizontal Applications:

AVM Drain Board 9000 provides protection for waterproofing systems and collecting excess water in planters, rooftop gardens, and other horizontal surfaces such as in-between slab waterproofing applications. The filter fabric retains soil or sand particles as well as freshly placed concrete or grout, allowing filtered water to pass into the drainage core. The collected water is then conveyed to a proper collection system.

Where to Use

AVM Drain Board 9000/9020/9080 is ideal for use with planters, roof gardens, plaza decks, split-slabs, and under slabs.

AVM Drain Board 9000

Consists of a heavy duty impermeable polymeric sheet cusped under heat and pressure to form a high flow dimpled drainage core. The core is then bonded to a layer of woven filter fabric. The filter fabric retains soil or sand particles as well as freshly placed concrete or grout, allowing filtered water to pass into the drainage core.

AVM Drain Board 9020

The identical properties as AVM Drain Board 9000 with the addition of a protection sheet bonded to the back side of the cusped core providing protection for soft membrane waterproofing systems. AVM Drain Board 9020 is compatible with waterproofing without the use of a protection board.

AVM Drain Board 9080

Consists of a heavy-duty impermeable polymeric cusped sheet bonded to a layer of heavy-duty non-woven filter fabric (8 oz./sq. yd).



Delivery, Storage, and Handling

- Packing and shipping: Provide materials in original unopened containers with manufacturer's labels intact and legible.
- Acceptance at site:
 - Unload materials: check for damage.
 - Damaged materials determined by visual inspection will not be accepted.
 - Remove rejected materials from site immediately.
- Storage and protection:
 - Store materials in dry area in manufacturer's protective packaging with labels and installation instructions intact.
 - Store materials under cover, off ground; protect from sunlight.
 - Transmissivity or Flow Q with hydraulic gradient of 1 with confining stress indicated in MANUFACTURED UNITS Article in accord with ASTM D4716-01

Project Conditions

- All surfaces to which the Drainage Boards are applied to must be clean, sound and stable enough to properly attach and hold onto the drain boards being installed.
- Warn personnel against hazards of working with this product. Sharp edges, weight, etc. Note other hazardous conditions on the job that might require special attention or extra protective gear and or any other special protective or safety procedures.
- Protect adjacent surfaces which could be damaged during the application procedure.

Inspection of Substrates

- Verify 1% slope to underslab collection pipes or site water drainage system at underslab drainage system location substrate.
- Examine conditions and substrates where products specified in this section are installed; submit written notification of unacceptable conditions or substrates.

System Application

Refer to installation instructions.

Quality Control

- Visually inspect all drain board surfaces to ensure a full and proper drain board system application, especially at corners, drainage footings and other hard-to-reach areas.
- All unsatisfactory areas shall be repaired prior to final acceptance.

Protection of Installed Work

Always protect the waterproofing and drainage system until fully covered with dirt, concrete, shot-crete, etc.

Availability and Cost

Contact AVM Industries or your approved applicator for pricing and availability.

Technical Services

Technical services are available by contacting our offices at: **888.414.1041** or **818.888.0050** or visit www.avmindustries.com

System Specifications

See next page.

Physical Properties

Core	9000/9020	9080
Compressive Strength (ASTM D-1621)	21,000 psf (1005 kNm ²)	21,000 psf (1005 kNm ²)
Thickness (ASTM D-1777)	.40" (10.16 mm)	.40" (10.16 mm)
Flow (Hydraulic gradient = 1) (ASTM D-4716)	21 g/min/ft (261 L/min/m)	21 g/min/ft (261 L/min/m)

Fabric	9000/9020	9080
Flow (ASTM D-4491)	145 gal/min/ft ² (5907 L/min/m ²)	95 gal/min/ft ² (3866 L/min/m ²)
Puncture (ASTM D-4833)	100 lbs. (.44 kN)	130 lbs. (.58 kN)
AOS (EOS)	40 U.S. Sieve (.42 mm)	90 U.S. Sieve (.18 mm)
Grab Tensile (ASTM D-4632)	355 lbs. (1.62 kN)	205 lbs. (.90 kN)

General Characteristics				
Roll Length	Roll Width	Roll Weight (approx. lbs.)		
		9000	9020	9080
50 ft. (15.24 m)	4 ft. (1.22 m)	50.0	50.0	
50 ft. (15.24 m)	8 ft. (2.43 m)	100.0	100.0	

Notes:

All AVM Drain Board 9000 versions are "Special Order" items. Allow 2 weeks lead time for special order items. For pricing and availability of special order items, please contact AVM Industries or your local distributor.

For a complete list of details in CAD or PDF, please visit our website at www.avmindustries.com.

AVM Industries, Inc.
 8245 Remmet Ave, Canoga Park, CA 91304
 888.414.1041 818.888.0050

Quality Waterproofing Products



www.avmindustries.com



AVM Aussie Mate 580-AL

AVM Bituminous Sheet Waterproofing Membrane

Safety Data Sheet

Prepared according to Federal Register / Vol. 77, No. 58 / Monday, March 26, 2012 / Rules and Regulations

Revision date: 02/24/2017 Supersedes: Version: 1.0

SECTION 1: Identification of the substance/mixture and of the company/undertaking

1.1. Product identifier

Product name : AVM Aussie Mate 580-AL
Product form : Mixtures
Other means of identification : Bituminous Sheet Waterproofing Membrane with Aluminum Protection Layer

1.2. Relevant identified uses of the substance or mixture and uses advised against

1.3. Details of the supplier of the safety data sheet

AVM Industries, Inc.
8245 Remmet Ave
Canoga Park, CA 91304
Tel: 818-888-0050
Fax: 818-888-0030
www.avmindustries.com

1.4. Emergency telephone number

No additional information available

SECTION 2: Hazards identification

2.1. Classification of the substance or mixture

GHS-US classification

Carc. 2 H351

2.2. Label elements

GHS-US labelling

Hazard pictograms (GHS-US) :



GHS08

Signal word (GHS-US) :

Warning

Hazard statements (GHS-US) :

H351 - Suspected of causing cancer

Precautionary statements (GHS-US) :

P201 - Obtain special instructions before use
P202 - Do not handle until all safety precautions have been read and understood
P280 - Wear eye protection, face protection, protective gloves, protective clothing
P308+P313 - If exposed or concerned: Get medical advice/attention
P405 - Store locked up
P501 - Dispose of contents/container to a licensed hazardous-waste disposal contractor or collection site except for empty clean containers which can be disposed of as non-hazardous waste

2.3. Other hazards

No additional information available

2.4. Unknown acute toxicity (GHS US)

No data available

SECTION 3: Composition/information on ingredients

3.1. Substances

Not applicable

3.2. Mixtures

Name	Product identifier	%
Asphalt	(CAS No) 8052-42-4	15 - 40*
Talc	(CAS No) 14807-96-6	10 - 30*

*In accordance with paragraph (i) of the OSHA Hazard Communication Standard (29 CFR §1910.1200), the specific chemical identity or exact weight % has been withheld as a trade secret

AVM Aussie Mate 580-AL (Bitumenous Waterproofing Sheet)

Safety Data Sheet

Prepared according to Federal Register / Vol. 77, No. 58 / Monday, March 26, 2012 / Rules and Regulations

SECTION 4: First aid measures

4.1. Description of first aid measures

- First-aid measures general : If exposed or concerned, get medical attention/advice. Show this safety data sheet to the doctor in attendance. Wash contaminated clothing before re-use. Never give anything to an unconscious person.
- First-aid measures after inhalation : IF INHALED: Remove to fresh air and keep at rest in a position comfortable for breathing. Get medical attention if breathing is affected. If breathing is difficult, supply oxygen.
- First-aid measures after skin contact : IF ON SKIN (or clothing): Remove affected clothing and wash all exposed skin with water for at least 15 minutes. If irritation develops or persists, get medical attention.
- First-aid measures after eye contact : IF IN EYES: Immediately flush with plenty of water for at least 15 minutes. Remove contact lenses if present and easy to do so. Continue rinsing if pain, blinking, or irritation develops or persists, get medical attention. Continue rinsing.
- First-aid measures after ingestion : IF SWALLOWED: rinse mouth thoroughly. Do not induce vomiting without advice from poison control center. Get medical attention if you feel unwell.

4.2. Most important symptoms and effects, both acute and delayed

- Symptoms/injuries : Suspected of causing cancer.
- Symptoms/injuries after inhalation : May cause respiratory irritation.
- Symptoms/injuries after skin contact : May cause skin irritation.
- Symptoms/injuries after eye contact : Direct contact with eyes is likely to be irritating.
- Symptoms/injuries after ingestion : May cause gastrointestinal irritation.
- Chronic symptoms : Suspected of causing cancer.

4.3. Indication of any immediate medical attention and special treatment needed

No additional information available.

SECTION 5: Fire-fighting measures

5.1. Extinguishing media

- Suitable extinguishing media : Dry powder. Carbon Dioxide (CO₂). Earth. Sand. Foam.
- Unsuitable extinguishing media : Water.

5.2. Special hazards arising from the substance or mixture

- Reactivity : No dangerous reactions known under normal conditions of use.

5.3. Advice for firefighters

- Precautionary measures fire : Keep away from heat, hot surfaces, sparks, open flames and other ignition sources. No smoking.
- Firefighting instructions : Use water spray or fog for cooling exposed containers. Exercise caution when fighting any chemical fire. Do not dispose of fire-fighting water in the environment.
- Protection during firefighting : Do not enter fire area without proper protective equipment, including respiratory protection.
- Other information : Vapor is heavier than air. Combustion produces toxic gases.

SECTION 6: Accidental release measures

6.1. Personal precautions, protective equipment and emergency procedures

- General measures : Evacuate area. Ventilate area. Keep upwind. Spill should be handled by trained clean-up crews properly equipped with respiratory equipment and full chemical protective gear (see Section 8).

6.1.1. For non-emergency personnel

- Protective equipment : Wear Protective equipment as described in Section 8.
- Emergency procedures : Evacuate unnecessary personnel.

6.1.2. For emergency responders

- Protective equipment : Wear suitable protective clothing, gloves and eye or face protection. Approved supplied-air respirator, in case of emergency.

6.2. Environmental precautions

Prevent entry to sewers and public waters. Notify authorities if liquid enters sewers or public waters. Avoid release to the environment.

6.3. Methods and material for containment and cleaning up

- For containment : Contain any spills with dikes or absorbents to prevent migration and entry into sewers or streams.
- Methods for cleaning up : Soak up spills with inert solids, such as clay or diatomaceous earth as soon as possible. This material and its container must be disposed of in a safe way, and as per local legislation.

6.4. Reference to other sections

See Sections 8 and 13.

AVM Aussie Mate 580-AL (Bitumenous Waterproofing Sheet)

Safety Data Sheet

Prepared according to Federal Register / Vol. 77, No. 58 / Monday, March 26, 2012 / Rules and Regulations

SECTION 7: Handling and storage

7.1. Precautions for safe handling

Precautions for safe handling : Do not handle until all safety precautions have been read and understood. Do not get in eyes, on skin, or on clothing. Wash hands and other exposed areas with mild soap and water before eating, drinking or smoking and when leaving work.

7.2. Conditions for safe storage, including any incompatibilities

Storage conditions : Keep the container tightly closed. Store in dry, cool, well-ventilated area. Store away from Oxidizing agents, Peroxides, and Food items.

SECTION 8: Exposure controls/personal protection

8.1. Control parameters

Asphalt (8052-42-4)	
ACGIH TWA	0.5 mg/m ³
Remark (OSHA)	OELs not established
Talc (14807-96-6)	
ACGIH TWA	2 mg/m ³ particulate matter containing no asbestos and <1% crystalline silica, respirable fraction
OSHA PEL (TWA)	20 mppcf if 1% Quartz or more, use Quartz limit

8.2. Exposure controls

Appropriate engineering controls : Provide adequate general and local exhaust ventilation. Use process enclosures, local exhaust ventilation, or other engineering controls to control airborne levels below recommended exposure limits. Use explosion-proof equipment with flammable materials. Ensure adequate ventilation, especially in confined areas.

Personal protective equipment : Gloves. Protective goggles. Protective clothing.



Hand protection : Use gloves chemically resistant to this material when prolonged or repeated contact could occur. Gloves should be classified under Standard EN 374 or ASTM F1296. Suggested glove materials are: Neoprene, Nitrile/butadiene rubber, Polyethylene, Ethyl vinyl alcohol laminate, PVC or vinyl. Suitable gloves for this specific application can be recommended by the glove supplier.

Eye protection : Wear eye protection, including chemical splash goggles and a face shield when possibility exists for eye contact due to spraying liquid or airborne particles.

Skin and body protection : Wear long sleeves, and chemically impervious PPE/coveralls to minimize bodily exposure.

Respiratory protection : Use NIOSH (or other equivalent national standard) -approved dust/particulate respirator. Where vapor, mist, or dust exceed PELs or other applicable OELs, use NIOSH-approved respiratory protective equipment.

SECTION 9: Physical and chemical properties

9.1. Information on basic physical and chemical properties

Physical state : Solid
Color : Black.
Odor : Asphalt.
Odor Threshold : No data available
pH : No data available
Relative evaporation rate (butylacetate=1) : No data available
Melting point : No data available
Freezing point : No data available
Boiling point : No data available
Flash point : No data available
Auto-ignition temperature : No data available
Decomposition temperature : No data available
Flammability (solid, gas) : No data available
Vapour pressure : No data available
Relative vapour density at 20 °C : No data available
Relative density : No data available

AVM Aussie Mate 580-AL (Bitumenous Waterproofing Sheet)

Safety Data Sheet

Prepared according to Federal Register / Vol. 77, No. 58 / Monday, March 26, 2012 / Rules and Regulations

Solubility	: Insoluble in water.
Log Pow	: No data available
Log Kow	: No data available
Viscosity, kinematic	: No data available
Viscosity, dynamic	: No data available
Explosive properties	: No data available
Oxidising properties	: No data available
Explosive limits	: No data available

9.2. Other information

No additional information available

SECTION 10: Stability and reactivity

10.1. Reactivity

No dangerous reactions known under normal conditions of use.

10.2. Chemical stability

Stable under recommended handling and storage conditions (see section 7).

10.3. Possibility of hazardous reactions

None known.

10.4. Conditions to avoid

Ignition sources. Heat. Open flame. Sparks.

10.5. Incompatible materials

Oxidizing agents. Strong acids. Alkalis. Halogens.

10.6. Hazardous decomposition products

Combustion produces toxic gases.

SECTION 11: Toxicological information

11.1. Information on toxicological effects

Acute toxicity	: Not classified
Skin corrosion/irritation	: Not classified
Serious eye damage/irritation	: Not classified
Respiratory or skin sensitisation	: Not classified
Germ cell mutagenicity	: Not classified
Carcinogenicity	: Suspected of causing cancer.

Asphalt (8052-42-4)

IARC group	2B - Possibly carcinogenic to humans
------------	--------------------------------------

Talc (14807-96-6)

IARC group	2B - Possibly carcinogenic to humans
------------	--------------------------------------

Reproductive toxicity	: Not classified
Specific target organ toxicity (single exposure)	: Not classified
Specific target organ toxicity (repeated exposure)	: Not classified
Aspiration hazard	: Not classified
Symptoms/injuries after inhalation	: May cause respiratory irritation.
Symptoms/injuries after skin contact	: May cause skin irritation.
Symptoms/injuries after eye contact	: Direct contact with eyes is likely to be irritating.
Symptoms/injuries after ingestion	: May cause gastrointestinal irritation.
Chronic symptoms	: Suspected of causing cancer.

SECTION 12: Ecological information

12.1. Toxicity

No additional information available

12.2. Persistence and degradability

AVM Bituminous Sheet Waterproofing Membrane

Persistence and degradability	The product is not biodegradable.
-------------------------------	-----------------------------------

AVM Aussie Mate 580-AL (Bitumenous Waterproofing Sheet)

Safety Data Sheet

Prepared according to Federal Register / Vol. 77, No. 58 / Monday, March 26, 2012 / Rules and Regulations

12.3. Bioaccumulative potential

AVM Bituminous Sheet Waterproofing Membrane	
Bioconcentration factor (BCF REACH)	Unlikely bioconcentration
Bioaccumulative potential	No possible bioaccumulation.

12.4. Mobility in soil

No additional information available

12.5. Other adverse effects

No additional information available

SECTION 13: Disposal considerations

13.1. Waste treatment methods

Waste treatment methods : Obtain the consent of pollution control authorities before discharging to wastewater treatment plants.

Waste disposal recommendations : Dispose in a safe manner in accordance with local/national regulations.

SECTION 14: Transport information

In accordance with DOT

Not hazardous for transport

Additional information

Other information : No supplementary information available.

Transport by sea

No additional information available

Air transport

No additional information available

SECTION 15: Regulatory information

15.1. US Federal regulations

AVM Bituminous Sheet Waterproofing Membrane	
All chemical substances in this product are listed in the EPA (Environment Protection Agency) TSCA (Toxic Substances Control Act) Inventory or are exempt	
SARA Section 311/312 Hazard Classes	Delayed (chronic) health hazard

15.2. International regulations

No additional information available.

15.3. US State regulations

California Proposition 65: WARNING! This product contains chemicals known to the state of California to cause cancer, birth defects, or other reproductive harm.

Asphalt (8052-42-4)
U.S. - New Jersey - Right to Know Hazardous Substance List U.S. - Pennsylvania - RTK (Right to Know) List U.S. - Massachusetts - Right To Know List
Talc (14807-96-6)
U.S. - Massachusetts - Right To Know List U.S. - New Jersey - Right to Know Hazardous Substance List U.S. - Pennsylvania - RTK (Right to Know) List

SECTION 16: Other information

Indication of changes : Revision 1.0: New SDS Created.

Revision date : 02/24/2017

Other information : Author: BCS.

AVM Aussie Mate 580-AL (Bitumenous Waterproofing Sheet)

Safety Data Sheet

Prepared according to Federal Register / Vol. 77, No. 58 / Monday, March 26, 2012 / Rules and Regulations

NFPA health hazard	: 2 - Materials that, under emergency conditions, can cause temporary incapacitation or residual injury.
NFPA fire hazard	: 0 - Materials that will not burn under typical fire conditions, including intrinsically noncombustible materials such as concrete, stone, and sand.
NFPA reactivity	: 0 - Material that in themselves are normally stable, even under fire conditions.

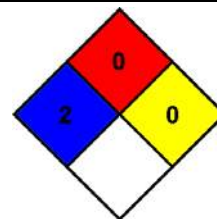

HMIS III Rating

Health	: 2*
Flammability	: 0
Physical	: 0
Personal protection	:

This information is based on our current knowledge and is intended to describe the product for the purposes of health, safety and environmental requirements only. It should not therefore be construed as guaranteeing any specific property of the product

Safety Data Sheet

1. Product and Company Identification

Product Name: AVM Primer 580-SB-HV

Product Use: Primer for porous surfaces
Uses Advised Against: None known

Manufacturer: AVM Industries, Inc.
8245 Remmet Ave, Canoga Park CA 91304-4133
www.avmindustries.com

Information Phone Number: (818) 888-0050
Emergency Phone Number: Chemtrec 800-424-9300

SDS Date of Preparation: February 20, 2023

2. Hazards Identification

GHS Classification:

Physical:	Health:
Flammable Liquid Category 2	Eye Irritation Category 2A Skin Irritation Category 2 Specific Target Organ Toxicity Single Exposure Category 3 (Narcotic Effects) Reproductive Toxicity Category 2 Carcinogen Category 2 Aspiration Toxicity Category 1

GHS Label Elements:

Danger!



H225 Highly flammable liquid and vapor.
H304 May be fatal if swallowed and enters airways
H315 Causes skin irritation.
H319 Causes serious eye irritation.
H336 May cause drowsiness and dizziness.
H351 Suspected of causing cancer.
H361 Suspected of damaging the unborn child.

P201 Obtain special instructions before use.
P202 Do not handle until all safety precautions have been read and understood.
P210 Keep away from heat, hot surfaces, sparks, open flames, and other ignition sources. No smoking.
P233 Keep container tightly closed.
P240 Ground or bond container and receiving equipment.
P241 Use explosion-proof electrical, ventilating, and lighting equipment.
P242 Use only non-sparking tools.
P243 Take precautionary measures against static discharge.
P261 Avoid breathing mists or vapors.
P264 Wash face, hands and any exposed skin thoroughly after handling.
P271 Use only outdoors or in a well-ventilated area.
P280 Wear protective gloves, protective clothing, and eye protection.
P308+P313 IF exposed or concerned: Get medical attention.
P303+P361+P353 IF ON SKIN (or hair): Take off immediately all contaminated clothing. Rinse skin with water or shower.
P333+P313 If skin irritation occurs: Get medical attention.

Safety Data Sheet

P362+P364 Take off contaminated clothing and wash it before reuse.

P304+P340 IF INHALED: Remove person to fresh air and keep comfortable for breathing.

P312 Call a POISON CENTER or doctor if you feel unwell.

P305+P351+P338 IF IN EYES: Rinse cautiously with water for several minutes. Remove contact lenses, if present and easy to do. Continue rinsing.

P337 + P313 If eye irritation persists: Get medical attention.

P301 +P310 IF SWALLOWED: Immediately call a Poison Center or doctor.

P331 DO NOT induce vomiting.

P370+P378 In case of fire: Use water fog or spray, foam, carbon dioxide or dry chemical to extinguish.

P403+P235 Store in a well-ventilated place. Keep cool.

P405 Store locked up.

P501 Dispose of contents and container in accordance with local and national regulations.

Hazards not otherwise specified: None

3. Composition/Information on Ingredients

Component	CAS No.	Amount
Naphtha (petroleum) hydrotreated light / Heptane	64742-49-0 / 426260-76-6 / 142-82-5	40-50%
Acetone	67-64-1	15-40%
Butanone (Methyl ethyl ketone)	78-93-3	0.5-1.5%
Toluene	108-88-3	0.1-<1%
4-Methylpentan-2-one (Methyl isobutyl ketone)	108-10-1	0.1-<1%

The specific identity and/or exact percentage (concentration) of composition has been withheld as a trade secret.

4. First Aid Measures

Inhalation: Remove victim to fresh air. If breathing is difficult or irritation persists, get medical attention.

Skin Contact: Remove contaminated clothing and shoes. Flush skin thoroughly with water for several minutes. Get medical attention if irritation persists. Launder clothing before re-use.

Eye Contact: Immediately flush eyes thoroughly with large quantities of water for 15 minutes, while holding the eye lids open to be sure the material is washed out. Remove contact lenses if present and easy to do. Get medical attention if irritation persists.

Ingestion: DO NOT induce vomiting. Keep the victim calm and warm. Get immediate medical attention.

Most Important Symptoms: Causes eye and skin irritation. Inhalation of mists or vapors may cause headache, dizziness, nausea and other symptoms of central nervous system depression. Ingestion may cause abdominal discomfort or pain, nausea, vomiting, drowsiness, and central nervous system effects. Aspiration into the lungs during swallowing or vomiting may cause serious lung damage and may be fatal. This product contains toluene which may cause reproductive harm. This product contains methyl isobutyl ketone, which is suspected of causing cancer.

Indication of Immediate Medical Attention/Special Treatment: Immediate medical attention is required for ingestion.

5. Firefighting Measures

Suitable (and Unsuitable) Extinguishing Media: Use water fog or spray, foam, carbon dioxide or dry chemical.

Specific Hazards Arising from the Chemical: Highly flammable liquid and vapor. Vapors are heavier than air and may travel along surfaces to remote ignition sources and flash back. Vapors may form explosive mixtures with

Safety Data Sheet

air in confined areas. Vapors may cause flash fire. Thermal decomposition will generate oxides of carbon and toxic and irritating smoke and gases.

Special Fire Fighting Procedures: Firefighters should always wear positive pressure self-contained breathing apparatus and full protective clothing. Cool fire-exposed containers with water.

6: Accidental Release Measures

Personal Precautions, Protective Equipment, and Emergency Procedures: Evacuate spill area and keep unprotected personnel away. Eliminate all sources of ignition. Use non-sparking tools and equipment. Ventilate area with explosion proof equipment. Wear appropriate protective clothing and equipment.

Methods and Materials for Containment and Clean-Up: Cover with an inert absorbent material and collect into an appropriate container for disposal. Use with non-sparking tools and explosion proof equipment.

Environmental Precautions: Prevent entry into storm sewers and waterways. Report spill as required by local and national regulations.

7. Handling and Storage

Precautions for Safe Handling: Avoid breathing mists or vapors. Use with adequate ventilation. Avoid contact with the eyes, skin and clothing. Always wear impervious gloves, chemical safety goggles and protective clothing when handling this material. Wash thoroughly after handling. Do not eat, drink or smoke in the work area. Keep product away from heat, sparks, flames and all other sources of ignition. No smoking in storage or use areas. Keep containers closed when not in use. Use with non-sparking tools and explosion proof equipment. Electrically bond and ground containers for transfer.

Do not pressurize, cut, weld, braze, solder, drill, grind on or near containers or expose containers to heat or sources of ignition.

Conditions for Safe Storage, Including any Incompatibilities: Store in a cool, dry, well-ventilated location away from heat, direct sunlight, and sources of ignitions. Keep away from incompatible materials. Keep containers closed when not in use.

8. Exposure Controls / Personal Protection

Exposure Guidelines:

CHEMICAL	EXPOSURE LIMIT
Naphtha (petroleum) hydrotreated light / Heptane	400 ppm TWA, 500 ppm STEL ACGIH TLV 500 ppm TWA OSHA PEL
Acetone	250 ppm TWA, 500 ppm STEL ACGIH TLV 1000 ppm TWA OSHA PEL
Butanone (Methyl ethyl ketone)	200 ppm TWA 300 ppm STEL ACGIH TLV 200 ppm TWA OSHA PEL
Toluene	20 ppm TWA ACGIH TLV 200 ppm TWA, 300 ppm Ceiling, 500 ppm 10-minute peak OSHA PEL
4-Methylpentan-2-one (Methyl isobutyl ketone)	20 ppm TWA 75 ppm STEL ACGIH TLV 100 ppm TWA OSHA PEL

Appropriate Engineering Controls: Use with adequate general or local exhaust ventilation to maintain exposure levels below the occupational exposure limits. Use explosion proof electrical equipment and wiring where required.

Personal Protective Equipment

Respiratory Protection: For operations where the exposure limits may be exceeded, a NIOSH approved organic

Safety Data Sheet

vapor/particulate or supplied air respirator is recommended. Equipment selection depends on contaminant type and concentration. Select in accordance with 29 CFR 1910.134, all applicable laws and regulations; and good industrial hygiene practice.

Gloves: Impervious gloves are recommended to avoid skin contact.

Eye Protection: Chemical safety goggles are recommended.

Other Protective Equipment/Clothing: Wear appropriate protective clothing as needed to minimize skin contact.

9. Physical and Chemical Properties

Appearance and Odor: Green liquid with a solvent odor.

Physical State: Liquid	Odor Threshold: Not determined
pH: Not applicable	Specific Gravity: Not determined
Initial Boiling Point/Range: 132.9°F (56.08°C) (Acetone)	Vapor Pressure: Not determined
Melting/Freezing Point: Not determined	Vapor Density: >1 (air=1)
Solubility In Water: Insoluble	Percent Volatile: >50%
Viscosity: 250 mPa.s (room temperature)	Evaporation Rate: Not determined
Relative Density: 0.77	VOC Content: 500 g/L
Coefficient Of Water/Oil Distribution: Not determined	Autoignition Temp: Not determined
Flash Point: -9.4°F (-23°C)	Flammability (solid, gas): Not applicable
Flammability Limits: No data available	Decomposition Temperature: Not available
Particle Characteristics: Not applicable	

10. Stability and Reactivity

Reactivity: Not normally reactive.

Chemical Stability: Stable under normal storage and handling conditions.

Possibility of Hazardous Reactions: Hazardous reactions will not occur under normal conditions of storage and use.

Conditions to Avoid: Keep away from heat, sparks, flames and other sources of ignition.

Incompatible Materials: Strong oxidizing agents, strong acids, strong bases, potassium tert-butoxide.

Hazardous Decomposition Products: Thermal decomposition will generate oxides of carbon, acetic acid, tert-butanol and methanol.

11. Toxicological Information

Potential Health Effects:

Acute Hazards:

Inhalation: Inhalation of mists or vapors may cause nose and throat irritation with the possibility of central nervous system depression. Symptoms of central nervous system depression include headache, dizziness, drowsiness, nausea and unconsciousness.

Skin Contact: Causes moderate skin irritation.

Eye Contact: Causes serious eye irritation.

Ingestion: Swallowing may cause gastrointestinal irritation and central nervous system depression with symptoms similar to those described under inhalation.

Chronic Effects: Methyl isobutyl ketone is suspected of causing cancer. Toluene may cause damage to the nervous system and hearing through prolonged or repeated exposure and may cause adverse reproductive effects.

Safety Data Sheet

Carcinogenicity Listing: Methyl isobutyl ketone is listed by IARC as a suspected carcinogen (Group 2B) and Not Classifiable as a Confirmed Animal Carcinogen with Unknown Relevance to Humans (A3) by ACGIH. None of the other components above 0.1% are listed as a carcinogen or potential carcinogen by IARC, NTP, ACGIH or OSHA.

Reproductive Toxicity: This product contains Toluene which is suspected to cause harm to the unborn child.

Germ Cell Mutagenicity: Components are not classified for germ cell mutagenicity.

Numerical Measures of Toxicity:

Naphtha (petroleum) hydrotreated light/ Heptane	LD50 Oral Rat: >5000 mg/kg LD50 Skin Rabbit: >2,000 mg/kg LC50 Inhalation Rat: >29.9 mg/L/4 hr
Acetone	LD50 Oral Rat: 5800 mg/kg LD50 Skin Rabbit: 7400 mg/kg LC50 Inhalation Rat: 76 mg/L/4 hr
Butanone (Methyl ethyl ketone)	LD50 Oral Rat: 2183 mg/kg LD50 Skin Rabbit: 8000 mg/kg
Toluene	LD50 Oral Rat: >5000 mg/kg LD50 Skin Rabbit: >5000 mg/kg LC50 Inhalation Rat: >20 mg/L/4hr
4-Methylpentan-2-one (Methyl isobutyl ketone)	LD50 Oral Rat: 2080 mg/kg LC50 Inhalation Rat: 8.2-16.4 mg/L/4hr LD50 Skin Rat: >2000 mg/kg

12. Ecological Information

Ecotoxicity:

Acetone: LC50 Fathead Minnow 5540 mg/L/ 96 hr. EC50 daphnia magna 12,600 mg/L/48 hr. EC50 marine algae >430 mg/L/96 hr.

Butanone: LC50 Fathead Minnow 3220 mg/L/ 96 hr. EC50 daphnia magna 5091 mg/L/48 hr. EC50 algae >500 mg/L/96 hr.

This product is expected to be toxic to the aquatic environment with long-term adverse effects. Releases to the environment should be avoided.

Persistence and Degradability: No data available.

Bio accumulative Potential: No data available.

Mobility in Soil: No data available for product.

Other Adverse Effects: No data available.

13. Disposal Considerations

Dispose of in accordance with all local, state/provincial and federal regulations. Offer empty containers for recycling.

14. Transport Information

DOT Hazardous Materials Description: UN1133, Adhesives, 3, PG II

Safety Data Sheet

IMDG Dangerous Goods Description: UN1133, Adhesives, 3, PG II, Marine Pollutant

IATA Dangerous Goods Description: UN1133, Adhesives, 3, PG II

15. Regulatory Information

United States:

EPA TSCA INVENTORY: All of the components of this material are listed on the Toxic Substances Control Act (TSCA) Chemical Substances Inventory.

CERCLA Section 103: This product has an RQ of 12.500 lbs (based on the RQ of Acetone of 5,000 lbs present at 15-40%). Some states have more stringent reporting requirements. Report all spills in accordance with local, state, and federal regulations.

SARA Hazard Category (311/312): Classified under OSHA Hazcom 2012 GHS as per Section 2 of this SDS.

SARA 313: This product contains the following chemicals subject to Annual Release Reporting Requirements under SARA Title III, Section 313 (40 CFR 372): Toluene 0.1-<1%, Methyl Isobutyl Ketone 0.1-<1%

California Proposition 65:  **WARNING:** This product can expose you to chemicals including methyl isobutyl ketone, which is known to the State of California to cause cancer and toluene, which is known to the State of California to cause birth defects or other reproductive harm. For more information go to www.P65Warnings.ca.gov.

INTERNATIONAL INVENTORIES

Canada DSL: All the components are listed.

16. Other Information

DATE OF CURRENT REVISION: February 20, 2023
REVISION SUMMARY: New SDS
DATE OF PREVIOUS REVISION: -

This information is provided in good faith and is correct to the best of AVM Industries' knowledge as of the date hereof and is designed to assist our customers; however, AVM makes no representation as to its completeness or accuracy. This product is intended for sale to mainly professional contractor. We require customers to satisfy themselves as to the suitability for their specific applications. Any use which AVM Industries customers or third parties make of this information, or any reliance on, or decisions made based upon it, are the responsibility of such customer or third party. AVM Industries disclaims responsibility for damages, or liability of any kind resulting from the use of this information. THERE ARE NO WARRANTIES OR REPRESENTATIONS, EXPRESS OR IMPLIED, INCLUDING THOSE OF MERCHANTABILITY OR FITNESS FOR A PARTICULAR PURPOSE WITH RESPECT TO THIS INFORMATION OR TO THE PRODUCT IT DESCRIBES. IN NO EVENT SHALL AVM INDUSTRIES BE LIABLE FOR SPECIAL, INCIDENTAL, OR CONSEQUENTIAL DAMAGES.

Safety Data Sheet

1. Product and Company Identification

Product Name: AVM Primer 580-SB LV

Product Use: Primer for porous surfaces.
Uses Advised Against: None known

Manufacturer: AVM Industries, Inc.
8245 Remmet Ave, Canoga Park CA 91304-4133
www.avmindustries.com

Information Phone Number: (818) 888-0050
Emergency Phone Number: Chemtrec 800-424-9300

SDS Date of Preparation: February 21, 2023

2. Hazards Identification

GHS Classification:

Physical:	Health:
Flammable Liquid Category 2	Eye Irritation Category 2A Specific Target Organ Toxicity Single Exposure Category 3 (Narcotic Effects)

GHS Label Elements:

Danger!

H225 Highly flammable liquid and vapor.
H319 Causes serious eye irritation.
H336 May cause drowsiness and dizziness.



P210 Keep away from heat, sparks, open flames, and hot surfaces. No smoking.
P233 Keep container tightly closed.
P240 Ground or bond container and receiving equipment.
P241 Use explosion-proof electrical, ventilating, and lighting equipment.
P242 Use only non-sparking tools.
P243 Take precautionary measures against static discharge.
P261 Avoid breathing mists or vapors.
P264 Wash hands thoroughly after handling.
P271 Use only outdoors or in a well-ventilated area.
P280 Wear eye protection.
P303+P361+P353 IF ON SKIN (or hair): Take off immediately all contaminated clothing. Rinse skin with water or shower.
P304+P340 IF INHALED: Remove person to fresh air and keep comfortable for breathing.
P312 Call a POISON CENTER or doctor if you feel unwell.
P305+P351+P338 IF IN EYES: Rinse cautiously with water for several minutes. Remove contact lenses, if present and easy to do. Continue rinsing.
P337 + P313 If eye irritation persists: Get medical attention.
P370+P378 In case of fire: Use water fog or spray, foam, carbon dioxide or dry chemical to extinguish.
P403+P235 Store in a well-ventilated place. Keep cool.
P405 Store locked up.
P501 Dispose of contents and container in accordance with local and national regulations.

Hazards not otherwise specified: None

Safety Data Sheet

3. Composition/Information on Ingredients

Component	CAS No.	Amount
Methyl acetate	79-20-9	25-50%
tert-Butyl Acetate	540-88-5	10-25%
Cadmium	7440-43-9	<=0.001%

The specific identity and/or exact percentage (concentration) of composition has been withheld as a trade secret.

4. First Aid Measures

Inhalation: Remove victim to fresh air. If breathing is difficult or irritation persists, get medical attention.

Skin Contact: Remove contaminated clothing and shoes. Flush skin thoroughly with water for several minutes. Get medical attention if irritation persists. Launder clothing before re-use.

Eye Contact: Immediately flush eyes thoroughly with large quantities of water for 15 minutes, while holding the eye lids open to be sure the material is washed out. Remove contact lenses if present and easy to do. Get medical attention if irritation persists.

Ingestion: Do not induce vomiting unless directed to do so by medical personnel. Keep the victim calm and warm. Get medical attention if symptoms develop.

Most Important Symptoms: Causes eye irritation. Inhalation of mists or vapors may cause headache, dizziness, nausea and other symptoms of central nervous system depression. Ingestion may cause abdominal discomfort or pain, nausea, vomiting, drowsiness, and central nervous system effects.

Indication of Immediate Medical Attention/Special Treatment: Immediate medical attention is generally not required.

5. Firefighting Measures

Suitable (and Unsuitable) Extinguishing Media: Use water fog or spray, foam, carbon dioxide or dry chemical.

Specific Hazards Arising from the Chemical: Highly flammable liquid and vapor. Vapors are heavier than air and may travel along surfaces to remote ignition sources and flash back. Vapors may form explosive mixtures with air in confined areas. Vapors may cause flash fire. Thermal decomposition will generate oxides of carbon and toxic and irritating smoke and gases.

Special Fire Fighting Procedures: Firefighters should always wear positive pressure self-contained breathing apparatus and full protective clothing. Cool fire-exposed containers with water.

6: Accidental Release Measures

Personal Precautions, Protective Equipment, and Emergency Procedures: Evacuate spill area and keep unprotected personnel away. Eliminate all sources of ignition. Use non-sparking tools and equipment. Ventilate area with explosion proof equipment. Wear appropriate protective clothing and equipment.

Methods and Materials for Containment and Clean-Up: Cover with an inert absorbent material and collect into an appropriate container for disposal. Use with non-sparking tools and explosion proof equipment.

Environmental Precautions: Prevent entry into storm sewers and waterways. Report spill as required by local and national regulations.

Safety Data Sheet

7. Handling and Storage

Precautions for Safe Handling: Avoid breathing mists or vapors. Use with adequate ventilation. Avoid contact with the eyes, skin and clothing. Always eye protection when handling this material. Wash thoroughly after handling. Do not eat, drink or smoke in the work area. Keep product away from heat, sparks, flames and all other sources of ignition. No smoking in storage or use areas. Keep containers closed when not in use. Use with non-sparking tools and explosion proof equipment. Electrically bond and ground containers for transfer.

Do not pressurize, cut, weld, braze, solder, drill, grind on or near containers or expose containers to heat or sources of ignition.

Conditions for Safe Storage, Including any Incompatibilities: Store in a cool, dry, well ventilated location away from heat, direct sunlight, and sources of ignitions. Keep away from incompatible materials. Keep containers closed when not in use.

8. Exposure Controls / Personal Protection

Exposure Guidelines:

CHEMICAL	EXPOSURE LIMIT
Methyl acetate	200 ppm TWA, 250 ppm STEL ACGIH TLV 200 ppm TWA OSHA PEL
tert-Butyl Acetate	200 ppm TWA OSHA PEL
Cadmium	0.01 mg/m ³ (total) 0.002 mg/m ³ (respirable) TWA ACGIH TLV 0.005 mg/m ³ TWA OSHA PEL

Appropriate Engineering Controls: Use with adequate general or local exhaust ventilation to maintain exposure levels below the occupational exposure limits. Use explosion proof electrical equipment and wiring where required.

Personal Protective Equipment

Respiratory Protection: For operations where the exposure limits may be exceeded, a NIOSH approved organic vapor/particulate or supplied air respirator is recommended. Equipment selection depends on contaminant type and concentration. Select in accordance with 29 CFR 1910.134, all applicable laws and regulations; and good industrial hygiene practice.

Gloves: Impervious gloves are recommended to avoid skin contact.

Eye Protection: Chemical safety goggles are recommended.

Other Protective Equipment/Clothing: Wear appropriate protective clothing as needed to minimize skin contact.

9. Physical and Chemical Properties

Appearance and Odor: Red liquid with a solvent odor.

Physical State: Liquid	Odor Threshold: Not determined
pH: Not applicable	Specific Gravity: Not determined
Initial Boiling Point/Range: 134.6°F (57°C) (methyl acetate)	Vapor Pressure: Not determined
Melting/Freezing Point: Not determined	Vapor Density: >1 (air=1)
Solubility In Water: Insoluble	Percent Volatile: >35%
Viscosity: 400 mPa.s (room temperature)	Evaporation Rate: Not determined
Relative Density: 0.97	VOC Content: 0 g/L (according to EPA rules) / 240 g/L (according to SCAQMD rules)
Coefficient Of Water/Oil Distribution: Not determined	Autoignition Temp: Not determined
Flash Point: 14°F (-10°C)	Flammability (solid, gas): Not applicable

Safety Data Sheet

Flammability Limits: No data available	Decomposition Temperature: Not available
Particle Characteristics: Not applicable	

10. Stability and Reactivity

Reactivity: Not normally reactive.

Chemical Stability: Stable under normal storage and handling conditions.

Possibility of Hazardous Reactions: Hazardous reactions will not occur under normal conditions of storage and use.

Conditions to Avoid: Keep away from heat, sparks, flames and other sources of ignition.

Incompatible Materials: Strong oxidizing agents, strong acids, strong bases, potassium tert-butoxide.

Hazardous Decomposition Products: Thermal decomposition will generate oxides of carbon, acetic acid, tert-butanol and methanol.

11. Toxicological Information

Potential Health Effects:

Acute Hazards:

Inhalation: Inhalation of mists or vapors may cause nose and throat irritation with the possibility of central nervous system depression. Symptoms of central nervous system depression include headache, dizziness, drowsiness, nausea and unconsciousness.

Skin Contact: May cause mild skin irritation.

Eye Contact: Causes serious eye irritation.

Ingestion: Swallowing may cause gastrointestinal irritation and central nervous system depression with symptoms similar to those described under inhalation.

Chronic Effects: None known

Carcinogenicity Listing: Cadmium is classified by IARC and NTP as a known human carcinogen. None of the other components above 0.1% are listed as a carcinogen or potential carcinogen by IARC, NTP, ACGIH or OSHA.

Reproductive Toxicity: Not classified.

Germ Cell Mutagenicity: Not classified.

Numerical Measures of Toxicity:

Methyl acetate	LD50 Oral Rat: 6482 mg/kg LD50 Skin Rat: >2,000 mg/kg LC50 Inhalation Rat: >49.2 mg/L/4 hr
----------------	--

tert-Butyl Acetate	LD50 Oral Rat: 4500 mg/kg LD50 Skin Rabbit: >2000 mg/kg LC50 Inhalation Rat: 4211 ppm/6 hr
--------------------	--

12. Ecological Information

Ecotoxicity:

Methyl acetate: LC50 brachiopodium rerio 250 mg/L/ 96 hr. EC50 daphnia magna 1026 mg/L/48 hr. EC50 algae >120 mg/L/96 hr

tert-Butyl Acetate: LC50 rainbow trout 240 mg/L/ 96 hr. EC50 daphnia magna 350 mg/L/48 hr. EC50 64 mg/L/96hr

Safety Data Sheet

This product is expected to be toxic to the aquatic environment with long-term adverse effects. Releases to the environment should be avoided.

Persistence and Degradability: No data available

Bio accumulative Potential: No data available.

Mobility in Soil: No data available.

Other Adverse Effects: No data available.

13. Disposal Considerations

Dispose of in accordance with all local, state/provincial and federal regulations. Offer empty containers for recycling.

14. Transport Information

DOT Hazardous Materials Description: UN1133, Adhesives, 3, PG II

IMDG Dangerous Goods Description: UN1133, Adhesives, 3, PG II, Marine Pollutant

IATA Dangerous Goods Description: UN1133, Adhesives, 3, PG II

15. Regulatory Information

United States:

EPA TSCA INVENTORY: All of the components of this material are listed on the Toxic Substances Control Act (TSCA) Chemical Substances Inventory.

CERCLA Section 103: This product has an RQ of 20,000 lbs (based on the RQ of tert-Butyl Acetate of 5,000 lbs present at 10-25%). Some states have more stringent reporting requirements. Report all spills in accordance with local, state, and federal regulations.

SARA Hazard Category (311/312): Classified under OSHA Hazcom 2012 GHS as per Section 2 of this SDS.

SARA 313: This product contains the following chemicals subject to Annual Release Reporting Requirements under SARA Title III, Section 313 (40 CFR 372): None

California Proposition 65:  **WARNING:** This product can expose you to chemicals including Cadmium, which is known to the State of California to cause cancer, and toluene which is known to the State of California to cause birth defects or other reproductive harm. For more information go to www.P65Warnings.ca.gov.

INTERNATIONAL INVENTORIES

Canada DSL: All the components are listed.

16. Other Information

DATE OF CURRENT REVISION: February 21, 2023

REVISION SUMMARY: New SDS

DATE OF PREVIOUS REVISION: -

This information is provided in good faith and is correct to the best of AVM Industries' knowledge as of the date hereof and is designed to assist our customers; however, AVM makes no representation as to its completeness or accuracy. This product is

Safety Data Sheet

intended for sale to mainly professional contractor. We require customers to satisfy themselves as to the suitability for their specific applications. Any use which AVM Industries customers or third parties make of this information, or any reliance on, or decisions made based upon it, are the responsibility of such customer or third party. AVM Industries disclaims responsibility for damages, or liability of any kind resulting from the use of this information. THERE ARE NO WARRANTIES OR REPRESENTATIONS, EXPRESS OR IMPLIED, INCLUDING THOSE OF MERCHANTABILITY OR FITNESS FOR A PARTICULAR PURPOSE WITH RESPECT TO THIS INFORMATION OR TO THE PRODUCT IT DESCRIBES. IN NO EVENT SHALL AVM INDUSTRIES BE LIABLE FOR SPECIAL, INCIDENTAL, OR CONSEQUENTIAL DAMAGES.

SECTION 1: Identification of the substance/mixture and of the company/undertaking

1.1. Product identifier

Trade name : AVM Aussie Seal M
Product form : Mixtures

1.2. Relevant identified uses of the substance or mixture and uses advised against

Use of the substance/mixture : Sealant

1.3. Details of the supplier of the safety data sheet

AVM Industries, Inc.
8245 Remmet Ave
Canoga Park, CA 91304
Tel: 818-888-0050
Fax: 818-888-0030
www.avmindustries.com

1.4. Emergency telephone number

No additional information available

SECTION 2: Hazards identification

2.1. Classification of the substance or mixture

GHS-US classification

Skin Irrit. 2 H315
Eye Irrit. 2A H319
Skin Sens. 1 H317

2.2. Label elements

GHS-US labelling

Hazard pictograms (GHS-US) :



GHS07

Signal word (GHS-US) :

Warning

Hazard statements (GHS-US) :

H315 - Causes skin irritation
H317 - May cause an allergic skin reaction
H319 - Causes serious eye irritation

Precautionary statements (GHS-US) :

P261 - Avoid breathing mist, vapours
P264 - Wash hands, forearms and face thoroughly after handling
P272 - Contaminated work clothing must not be allowed out of the workplace
P280 - Wear eye protection, face protection, protective gloves, protective clothing
P302+P352 - If on skin: Wash with plenty of soap and water
P305+P351+P338 - IF IN EYES: Rinse cautiously with water for several minutes. Remove contact lenses, if present and easy to do. Continue rinsing
P321 - Specific treatment (see first aid instructions on this label)
P333+P313 - If skin irritation or rash occurs: Get medical advice/attention
P337+P313 - If eye irritation persists: Get medical advice/attention
P362+P364 - Take off contaminated clothing and wash it before reuse
P501 - Dispose of contents/container to a licensed hazardous-waste disposal contractor or collection site except for empty clean containers which can be disposed of as non-hazardous waste

2.3. Other hazards

No additional information available

2.4. Unknown acute toxicity (GHS US)

No data available

SECTION 3: Composition/information on ingredients

3.1. Substances

Not applicable

AVM Aussie Seal M

Safety Data Sheet

Prepared according to Federal Register / Vol. 77, No. 58 / Monday, March 26, 2012 / Rules and Regulations

3.2. Mixtures

Name	Product identifier	%
N-[3-(Trimethoxysilyl)propyl]-1,2-ethanediamine	(CAS No) 1760-24-3	1 - 3*

*In accordance with paragraph (i) of the OSHA Hazard Communication Standard (29 CFR §1910.1200), the specific chemical identity or exact weight % has been withheld as a trade secret

SECTION 4: First aid measures

4.1. Description of first aid measures

- First-aid measures general : If exposed or concerned, get medical attention/advice. Show this safety data sheet to the doctor in attendance. Wash contaminated clothing before re-use. Never give anything to an unconscious person.
- First-aid measures after inhalation : IF INHALED: Remove to fresh air and keep at rest in a position comfortable for breathing. Get medical attention if breathing is affected. If breathing is difficult, supply oxygen.
- First-aid measures after skin contact : IF ON SKIN (or clothing): Remove affected clothing and wash all exposed skin with water for at least 15 minutes. If irritation develops or persists, get medical attention.
- First-aid measures after eye contact : IF IN EYES: Immediately flush with plenty of water for at least 15 minutes. Remove contact lenses if present and easy to do so. Continue rinsing if pain, blinking, or irritation develops or persists, get medical attention. Continue rinsing.
- First-aid measures after ingestion : IF SWALLOWED: rinse mouth thoroughly. Do not induce vomiting without advice from poison control center. Get medical attention if you feel unwell.

4.2. Most important symptoms and effects, both acute and delayed

- Symptoms/injuries : Causes skin irritation. May cause an allergic skin reaction. Causes serious eye irritation.
- Symptoms/injuries after inhalation : May cause respiratory irritation.
- Symptoms/injuries after skin contact : Causes skin irritation. May cause an allergic skin reaction.
- Symptoms/injuries after eye contact : Causes serious eye irritation.
- Symptoms/injuries after ingestion : May cause gastrointestinal irritation.

4.3. Indication of any immediate medical attention and special treatment needed

No additional information available.

SECTION 5: Fire-fighting measures

5.1. Extinguishing media

Suitable extinguishing media : Water spray. carbon dioxide (CO₂). Extinguishing powder. Foam.

5.2. Special hazards arising from the substance or mixture

- Fire hazard : Not flammable.
- Explosion hazard : Product does present an explosion hazard.
- Reactivity : No dangerous reactions known under normal conditions of use.

5.3. Advice for firefighters

- Precautionary measures fire : Keep away from heat, hot surfaces, sparks, open flames and other ignition sources. No smoking.
- Firefighting instructions : Use water spray or fog for cooling exposed containers. Exercise caution when fighting any chemical fire. Do not dispose of fire-fighting water in the environment.
- Protection during firefighting : Do not enter fire area without proper protective equipment, including respiratory protection.
- Other information : Dense smoke emitted when burned without sufficient oxygen.

SECTION 6: Accidental release measures

6.1. Personal precautions, protective equipment and emergency procedures

General measures : Evacuate area. Ventilate area. Keep upwind. Spill should be handled by trained clean-up crews properly equipped with respiratory equipment and full chemical protective gear (see Section 8).

6.1.1. For non-emergency personnel

- Protective equipment : Wear Protective equipment as described in Section 8.
- Emergency procedures : Evacuate unnecessary personnel.

6.1.2. For emergency responders

Protective equipment : Wear suitable protective clothing, gloves and eye or face protection. Approved supplied-air respirator, in case of emergency.

6.2. Environmental precautions

Prevent entry to sewers and public waters. Notify authorities if liquid enters sewers or public waters. Avoid release to the environment.

6.3. Methods and material for containment and cleaning up

For containment : Contain any spills with dikes or absorbents to prevent migration and entry into sewers or streams.

AVM Aussie Seal M

Safety Data Sheet

Prepared according to Federal Register / Vol. 77, No. 58 / Monday, March 26, 2012 / Rules and Regulations

Methods for cleaning up : Ensure there is adequate ventilation. Soak up spills with inert solids, such as clay or diatomaceous earth as soon as possible. This material and its container must be disposed of in a safe way, and as per local legislation.

6.4. Reference to other sections

See Sections 8 and 13.

SECTION 7: Handling and storage

7.1. Precautions for safe handling

Precautions for safe handling : Do not handle until all safety precautions have been read and understood. Use only in well-ventilated areas. Do not get in eyes, on skin, or on clothing. Wash hands and other exposed areas with mild soap and water before eating, drinking or smoking and when leaving work.

7.2. Conditions for safe storage, including any incompatibilities

Storage conditions : Store in a dry, cool and well-ventilated place. Keep the container tightly closed.

SECTION 8: Exposure controls/personal protection

8.1. Control parameters

N-[3-(Trimethoxysilyl)propyl]-1,2-ethanediamine (1760-24-3)	
Remark (ACGIH)	OELs not established
Remark (OSHA)	OELs not established

8.2. Exposure controls

Appropriate engineering controls : Provide adequate general and local exhaust ventilation. Use process enclosures, local exhaust ventilation, or other engineering controls to control airborne levels below recommended exposure limits. Use explosion-proof equipment with flammable materials. Ensure adequate ventilation, especially in confined areas.

Personal protective equipment : Gloves. Protective goggles. Protective clothing.



Hand protection : Use gloves chemically resistant to this material when prolonged or repeated contact could occur. Gloves should be classified under Standard EN 374 or ASTM F1296. Suggested glove materials are: Neoprene, Nitrile/butadiene rubber, Polyethylene, Ethyl vinyl alcohol laminate, PVC or vinyl. Suitable gloves for this specific application can be recommended by the glove supplier.

Eye protection : Wear eye protection, including chemical splash goggles and a face shield when possibility exists for eye contact due to spraying liquid or airborne particles.

Skin and body protection : Wear long sleeves, and chemically impervious PPE/coveralls to minimize bodily exposure.

Respiratory protection : Use NIOSH (or other equivalent national standard) -approved dust/particulate respirator. Where vapor, mist, or dust exceed PELs or other applicable OELs, use NIOSH-approved respiratory protective equipment.

SECTION 9: Physical and chemical properties

9.1. Information on basic physical and chemical properties

Physical state : Liquid
Appearance : Paste.
Color : No data available
Odor : Mint.
Odor Threshold : No data available
pH : No data available
Relative evaporation rate (butylacetate=1) : No data available
Melting point : No data available
Freezing point : No data available
Boiling point : No data available
Flash point : No data available
Auto-ignition temperature : No data available
Decomposition temperature : No data available
Flammability (solid, gas) : No data available
Vapour pressure : < 1
Relative vapour density at 20 °C : > 1

AVM Aussie Seal M

Safety Data Sheet

Prepared according to Federal Register / Vol. 77, No. 58 / Monday, March 26, 2012 / Rules and Regulations

Relative density	: 1.41
Density	: 11.8 lbs./gal. (calculated)
Solubility	: Insoluble in water.
Log Pow	: No data available
Log Kow	: No data available
Viscosity, kinematic	: No data available
Viscosity, dynamic	: No data available
Explosive properties	: No data available
Oxidising properties	: No data available
Explosive limits	: No data available

9.2. Other information

VOC content : 14.14 g/l % Volatile: 1.00%

SECTION 10: Stability and reactivity

10.1. Reactivity

No dangerous reactions known under normal conditions of use.

10.2. Chemical stability

Stable under recommended handling and storage conditions (see section 7).

10.3. Possibility of hazardous reactions

None known.

10.4. Conditions to avoid

None known.

10.5. Incompatible materials

None known.

10.6. Hazardous decomposition products

Carbon oxides (CO, CO₂). Sulfur oxides. Hydrogen sulfide.

SECTION 11: Toxicological information

11.1. Information on toxicological effects

Acute toxicity : Not classified

AVM Aussie Seal M	
LD50 oral rat	> 2000 mg/kg
LD50 dermal rat	> 2000 mg/kg

Skin corrosion/irritation : Causes skin irritation.

Serious eye damage/irritation : Causes serious eye irritation.
(Causes corneal injury)

Respiratory or skin sensitisation : May cause an allergic skin reaction.

Germ cell mutagenicity : Not classified

Carcinogenicity : Not classified

Reproductive toxicity : Not classified

Specific target organ toxicity (single exposure) : Not classified

Specific target organ toxicity (repeated exposure) : Not classified

Aspiration hazard : Not classified

Symptoms/injuries after inhalation : May cause respiratory irritation.

Symptoms/injuries after skin contact : Causes skin irritation. May cause an allergic skin reaction.

Symptoms/injuries after eye contact : Causes serious eye irritation.

Symptoms/injuries after ingestion : May cause gastrointestinal irritation.

SECTION 12: Ecological information

12.1. Toxicity

Ecology - general : May cause long-term adverse effects in the environment.

12.2. Persistence and degradability

AVM Aussie Seal M	
Persistence and degradability	Heavily removable from water.

AVM Aussie Seal M

Safety Data Sheet

Prepared according to Federal Register / Vol. 77, No. 58 / Monday, March 26, 2012 / Rules and Regulations

12.3. Bioaccumulative potential

AVM Aussie Seal M	
Bioaccumulative potential	May be accumulated in organism.

12.4. Mobility in soil

No additional information available

12.5. Other adverse effects

No additional information available

SECTION 13: Disposal considerations

13.1. Waste treatment methods

Waste treatment methods : Obtain the consent of pollution control authorities before discharging to wastewater treatment plants.

Waste disposal recommendations : Dispose in a safe manner in accordance with local/national regulations. Do not allow the product to be released into the environment.

SECTION 14: Transport information

In accordance with DOT

Not hazardous for transport

Additional information

Other information : No supplementary information available.

Transport by sea

No additional information available

Air transport

No additional information available

SECTION 15: Regulatory information

15.1. US Federal regulations

AVM Aussie Seal M	
All chemical substances in this product are listed in the EPA (Environment Protection Agency) TSCA (Toxic Substances Control Act) Inventory or are exempt	
SARA Section 311/312 Hazard Classes	Immediate (acute) health hazard

15.2. International regulations

No additional information available.

15.3. US State regulations

California Proposition 65: This product does not contain any substances known to the state of California to cause cancer and/or reproductive harm

SECTION 16: Other information

Indication of changes : Revision 1.0: New SDS Created.

Revision date : 04/14/2017

Other information : Author: BCS.

NFPA health hazard : 2 - Materials that, under emergency conditions, can cause temporary incapacitation or residual injury.

NFPA fire hazard : 0 - Materials that will not burn under typical fire conditions, including intrinsically noncombustible materials such as concrete, stone, and sand.

NFPA reactivity : 0 - Material that in themselves are normally stable, even under fire conditions.

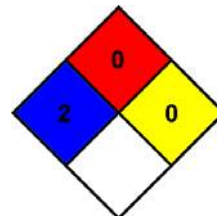

HMIS III Rating

Health : 2

Flammability : 0

Physical : 0

Personal protection :

This information is based on our current knowledge and is intended to describe the product for the purposes of health, safety and environmental requirements only. It should not therefore be construed as guaranteeing any specific property of the product



Aussie Swell Red

Safety Data Sheet

Prepared according to US 29 CFR 1910.1200 and Canadian HPR WHMIS 2015

Revision date: 12/11/2017

Version: 1.0

SECTION 1: Identification of the substance/mixture and of the company/undertaking

1.1. Product identifier

Product name : Aussie Swell red
Product form : Mixture

1.2. Relevant identified uses of the substance or mixture and uses advised against

1.3. Details of the supplier of the safety data sheet

AVM Industries, Inc.
8245 Remmet Ave
Canoga Park, CA 91304
Tel: 818-888-0050
Fax: 818-888-0030
www.avmindustries.com

1.4. Emergency telephone number

No additional information available

SECTION 2: Hazards identification

2.1. Classification of the substance or mixture

GHS classification

Acute Tox. 4 (Oral) H302
Carc. 1A H350
STOT RE 1 H372

2.2. Label elements

GHS labelling

Hazard pictograms (GHS) :



Signal word (GHS) :

Danger

Hazard statements (GHS) :

H302 - Harmful if swallowed
H350 - May cause cancer
H372 - Causes damage to organs through prolonged or repeated exposure (Inhalation)

Precautionary statements (GHS) :

P201 - Obtain special instructions before use
P202 - Do not handle until all safety precautions have been read and understood
P260 - Do not breathe dust
P264 - Wash hands, forearms and face thoroughly after handling
P270 - Do not eat, drink or smoke when using this product
P280 - Wear eye protection, protective gloves, protective clothing, respiratory protection
P301+P312 - If swallowed: Call a POISON CENTER, a doctor if you feel unwell
P308+P313 - If exposed or concerned: Get medical advice/attention
P314 - Get medical advice/attention if you feel unwell
P330 - Rinse mouth
P405 - Store locked up
P501 - Dispose of contents/container to a licensed hazardous-waste disposal contractor or collection site except for empty clean containers which can be disposed of as non-hazardous waste

2.3. Other hazards

No additional information available

2.4. Unknown acute toxicity (GHS)

No data available

SECTION 3: Composition/information on ingredients

3.1. Substances

Not applicable

3.2. Mixtures

Name	Product identifier	%
Silica: Crystalline, quartz	(CAS-No.) 14808-60-7	Not Available

*In accordance with paragraph (i) of the OSHA Hazard Communication Standard (29 CFR §1910.1200), the specific chemical identity or exact weight % has been withheld as a trade secret

Aussie Swell

Safety Data Sheet

Prepared according to US 29 CFR 1910.1200 and Canadian HPR WHMIS 2015

SECTION 4: First aid measures

4.1. Description of first aid measures

- First-aid measures general : If exposed or concerned, get medical attention/advice. Show this safety data sheet to the doctor in attendance. Wash contaminated clothing before re-use. Never give anything to an unconscious person.
- First-aid measures after inhalation : IF INHALED: Remove to fresh air and keep at rest in a position comfortable for breathing. Get medical attention if breathing is affected. If breathing is difficult, supply oxygen.
- First-aid measures after skin contact : IF ON SKIN (or clothing): Remove affected clothing and wash all exposed skin with water for at least 15 minutes. If irritation develops or persists, get medical attention.
- First-aid measures after eye contact : IF IN EYES: Immediately flush with plenty of water for at least 15 minutes. Remove contact lenses if present and easy to do so. Continue rinsing if pain, blinking, or irritation develops or persists, get medical attention. Continue rinsing.
- First-aid measures after ingestion : IF SWALLOWED: rinse mouth thoroughly. Do not induce vomiting without advice from poison control center. Get medical attention if you feel unwell.

4.2. Most important symptoms and effects, both acute and delayed

- Symptoms/effects : Harmful if swallowed. May cause cancer. Causes damage to organs through prolonged or repeated exposure.
- Symptoms/effects after inhalation : May cause respiratory irritation.
- Symptoms/effects after skin contact : May cause skin irritation.
- Symptoms/effects after eye contact : Direct contact with eyes is likely to be irritating.
- Symptoms/effects after ingestion : Harmful if swallowed.
- Chronic symptoms : May cause cancer. Causes damage to organs through prolonged or repeated exposure.

4.3. Indication of any immediate medical attention and special treatment needed

No additional information available.

SECTION 5: Firefighting measures

5.1. Extinguishing media

- Suitable extinguishing media : carbon dioxide (CO₂). Dry chemical. Foam. Use extinguishing media appropriate for surrounding fire.

5.2. Special hazards arising from the substance or mixture

- Fire hazard : Not flammable.
- Reactivity : No dangerous reactions known under normal conditions of use.

5.3. Advice for firefighters

- Precautionary measures fire : Keep away from heat, hot surfaces, sparks, open flames and other ignition sources. No smoking.
- Firefighting instructions : Use water spray or fog for cooling exposed containers. Exercise caution when fighting any chemical fire. Do not dispose of fire-fighting water in the environment.
- Protection during firefighting : Do not enter fire area without proper protective equipment, including respiratory protection.
- Other information : Thermal decomposition generates : carbon oxides (CO and CO₂).

SECTION 6: Accidental release measures

6.1. Personal precautions, protective equipment and emergency procedures

- General measures : Evacuate area. Ventilate area. Keep upwind. Spill should be handled by trained clean-up crews properly equipped with respiratory equipment and full chemical protective gear (see Section 8).

6.1.1. For non-emergency personnel

- Protective equipment : Wear Protective equipment as described in Section 8.
- Emergency procedures : Evacuate unnecessary personnel.

6.1.2. For emergency responders

- Protective equipment : Wear suitable protective clothing, gloves and eye or face protection. Approved supplied-air respirator, in case of emergency.

6.2. Environmental precautions

Avoid release to the environment. Prevent entry to sewers and public waters.

6.3. Methods and material for containment and cleaning up

- For containment : Contain and collect as any solid. Minimize generation of dust.
- Methods for cleaning up : Ventilate area. This material and its container must be disposed of in a safe way, and as per local legislation.

6.4. Reference to other sections

See Sections 8 and 13.

Aussie Swell

Safety Data Sheet

Prepared according to US 29 CFR 1910.1200 and Canadian HPR WHMIS 2015

SECTION 7: Handling and storage

7.1. Precautions for safe handling

Precautions for safe handling : Do not handle until all safety precautions have been read and understood. Do not breathe dust. Wash hands and other exposed areas with mild soap and water before eating, drinking or smoking and when leaving work.

7.2. Conditions for safe storage, including any incompatibilities

Storage conditions : Store in a dry place. Store in a closed container.

SECTION 8: Exposure controls/personal protection

8.1. Control parameters

Inert or Nuisance dust	
ACGIH TWA (mg/m ³)	3 mg/m ³ (respirable particles) 10 mg/m ³ (inhalable particles)
OSHA PEL (TWA) (mg/m ³)	5 mg/m ³ (respirable fraction) 15 mg/m ³ (total dust)

*Exposure limits are for inert or nuisance dust. No specific exposure limits have been established for this activated carbon product by the ACGIH. No specific exposure limits have been established for inert or nuisance dust by Canadian HPR.

Silica: Crystalline, quartz (14808-60-7)	
ACGIH TWA (mg/m ³)	0.025 mg/m ³ (respirable fraction)
OSHA PEL (TWA) (µg/m ³)	50 µg/m ³ (respirable crystalline silica)
Alberta (TWA)	0.025 mg/m ³ (respirable particulate)
British Columbia (TWA)	0.025 mg/m ³ (respirable particulate)
Manitoba (TWA)	0.025 mg/m ³ (respirable fraction)
New Brunswick (TWA)	0.025 mg/m ³ (respirable fraction)
Newfoundland and Labrador (TWA)	0.025 mg/m ³ (respirable fraction)
Northwest Territories (TWA)	0.05 mg/m ³ (respirable fraction)
Nova Scotia (TWA)	0.025 mg/m ³ (respirable particulate)
Nunavut (TWA)	0.05 mg/m ³ (respirable fraction)
Ontario (TWA)	0.10 mg/m ³ (respirable fraction)
Prince Edward Island (TWA)	0.025 mg/m ³ (respirable fraction)
Quebec (TWA)	0.10 mg/m ³ (respirable fraction)
Saskatchewan (TWA)	0.05 mg/m ³ (respirable fraction)
Yukon (TWA)	300 Particles/mL

8.2. Exposure controls

Appropriate engineering controls : Provide adequate general and local exhaust ventilation. Use process enclosures, local exhaust ventilation, or other engineering controls to control airborne levels below recommended exposure limits. Use explosion-proof equipment with flammable materials. Ensure adequate ventilation, especially in confined areas.

Personal protective equipment : Gloves. Protective goggles. Insufficient ventilation: wear respiratory protection.



Hand protection : Use gloves chemically resistant to this material when prolonged or repeated contact could occur. Gloves should be classified and selected according to regional or national standards. Suggested glove materials are: Neoprene, Nitrile/butadiene rubber, Polyethylene, Ethyl vinyl alcohol laminate PVC, or vinyl. Suitable gloves should be recommended by the glove supplier.

Eye protection : Wear eye protection, including chemical splash goggles and a face shield when possibility exists for eye contact due to spraying liquid or airborne particles.

Skin and body protection : Wear long sleeves, and chemically impervious PPE/coveralls to minimize bodily exposure.

Respiratory protection : Use NIOSH (or other equivalent national standard) -approved dust/particulate respirator. Where vapor, mist, or dust exceed PELs or other applicable OELs, use NIOSH-approved respiratory protective equipment.

Aussie Swell

Safety Data Sheet

Prepared according to US 29 CFR 1910.1200 and Canadian HPR WHMIS 2015

SECTION 9: Physical and chemical properties

9.1. Information on basic physical and chemical properties

Physical state	: Solid
Color	: Red.
Odor	: No data available.
Odor Threshold	: No data available
pH	: No data available
Relative evaporation rate (butylacetate=1)	: No data available
Melting point	: No data available
Freezing point	: No data available
Boiling point	: No data available
Flash point	: No data available
Auto-ignition temperature	: No data available
Decomposition temperature	: No data available
Flammability (solid, gas)	: No data available
Vapour pressure	: 0.00004 hPa estimated
Relative vapour density at 20 °C	: No data available
Relative density	: No data available
Solubility	: No data available
Log Pow	: No data available
Log Kow	: No data available
Viscosity, kinematic	: No data available
Viscosity, dynamic	: No data available
Explosive properties	: No data available
Oxidising properties	: No data available
Explosive limits	: No data available

9.2. Other information

VOC content	: 0 %
-------------	-------

SECTION 10: Stability and reactivity

10.1. Reactivity

No dangerous reactions known under normal conditions of use.

10.2. Chemical stability

Stable under recommended handling and storage conditions (see section 7).

10.3. Possibility of hazardous reactions

None known.

10.4. Conditions to avoid

None known.

10.5. Incompatible materials

None known.

10.6. Hazardous decomposition products

Thermal decomposition generates : Carbon oxides (CO, CO₂).

SECTION 11: Toxicological information

11.1. Information on toxicological effects

Acute toxicity : Oral: Harmful if swallowed.

Silica: Crystalline, quartz (14808-60-7)

LD50 oral rat	500 mg/kg
Skin corrosion/irritation	: Not classified
Serious eye damage/irritation	: Not classified
Respiratory or skin sensitisation	: Not classified
Germ cell mutagenicity	: Not classified
Carcinogenicity	: May cause cancer.

Silica: Crystalline, quartz (14808-60-7)

IARC group	1 - Carcinogenic to humans
------------	----------------------------

Aussie Swell

Safety Data Sheet

Prepared according to US 29 CFR 1910.1200 and Canadian HPR WHMIS 2015

Reproductive toxicity	: Not classified
Specific target organ toxicity (single exposure)	: Not classified
Specific target organ toxicity (repeated exposure)	: Causes damage to organs through prolonged or repeated exposure (Inhalation).
Aspiration hazard	: Not classified
Symptoms/effects after inhalation	: May cause respiratory irritation.
Symptoms/effects after skin contact	: May cause skin irritation.
Symptoms/effects after eye contact	: Direct contact with eyes is likely to be irritating.
Symptoms/effects after ingestion	: Harmful if swallowed.
Chronic symptoms	: May cause cancer. Causes damage to organs through prolonged or repeated exposure.

SECTION 12: Ecological information

12.1. Toxicity

Ecology - general : Not expected to be ecotoxic.

12.2. Persistence and degradability

No additional information available

12.3. Bioaccumulative potential

No additional information available

12.4. Mobility in soil

No additional information available

12.5. Other adverse effects

No additional information available

SECTION 13: Disposal considerations

13.1. Waste treatment methods

Waste treatment methods : Obtain the consent of pollution control authorities before discharging to wastewater treatment plants.

Product/Packaging disposal recommendations : Dispose in a safe manner in accordance with local/national regulations.

SECTION 14: Transport information

In accordance with DOT/TDG

Not hazardous for transport

Additional information

Other information : No supplementary information available.

Transport by sea

No additional information available

Air transport

No additional information available

SECTION 15: Regulatory information

15.1. US Federal regulations

Aussie Swell

All chemical substances in this product are listed in the EPA (Environment Protection Agency) TSCA (Toxic Substances Control Act) Inventory or are exempt

SARA Section 311/312 Hazard Classes

Health hazard - Acute toxicity (any route of exposure)

Health hazard - Carcinogenicity

Health hazard - Specific target organ toxicity (single or repeated exposure)

15.2. Canada regulations

Aussie Swell

All chemical substances in this product are listed on the Canadian Domestic Substances List (DSL) or Non-Domestic Substances List (NDSL) or are exempt

Aussie Swell

Safety Data Sheet

Prepared according to US 29 CFR 1910.1200 and Canadian HPR WHMIS 2015

15.3. US State regulations

WARNING! This product contains chemicals known to the state of California to cause cancer, birth defects, or other reproductive harm.

Silica: Crystalline, quartz (14808-60-7)				
U.S. - California - Proposition 65 - Carcinogens List	U.S. - California - Proposition 65 - Developmental Toxicity	U.S. - California - Proposition 65 - Reproductive Toxicity - Female	U.S. - California - Proposition 65 - Reproductive Toxicity - Male	No significant risk level (NSRL)
Yes	No	No	No	Not available

Silica: Crystalline, quartz (14808-60-7)
U.S. - New Jersey - Right to Know Hazardous Substance List U.S. - Massachusetts - Right To Know List U.S. - Pennsylvania - RTK (Right to Know) List

SECTION 16: Other information

Indication of changes : Revision 1.0: New SDS Created.
Revision date : 12/11/2017
Other information : Author: BCS.

NFPA health hazard : 3 - Materials that, under emergency conditions, can cause serious or permanent injury.
NFPA fire hazard : 0 - Materials that will not burn under typical dire conditions, including intrinsically noncombustible materials such as concrete, stone, and sand.
NFPA reactivity : 0 - Material that in themselves are normally stable, even under fire conditions.

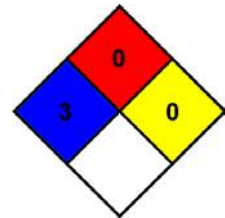

Hazard Rating

Health : 3*
Flammability : 0
Physical : 0
Personal protection :

This information is based on our current knowledge and is intended to describe the product for the purposes of health, safety and environmental requirements only. It should not therefore be construed as guaranteeing any specific property of the product

MATERIAL SAFETY DATA SHEET

AVM Drain Boards 2000, 2200, 6000, 6020, 9000, 9020, 9080, XL, 9900 & SWD Series

AVM INDUSTRIES, INC.
8245 Remmet Ave
Canoga Park, CA 91304

Phone: (818) 888-0050
(888) 414-1041
Fax: (818) 888-0030

PRODUCT IDENTIFICATION:

AVM INDUSTRIES, INC. NAME: AVM Drain Boards

Components:

Non-woven polypropylene fabric: (AVM Drain Boards 2000, 2200, 6000, 6020 & SWD)

Woven monofilament fabric: (AVM Drain Boards 9000 & 9020)

Extruded high impact polystyrene sheet and/or polyethylene

D.O.T. Proper Shipping Name: Not a regulated material

HAZARDOUS INGREDIENTS:

This product does not meet the definition given in 29 CRF Part 1910.1200 (OSHA).
Information is furnished as a customer service.

OCCUPATIONAL CONTROL PROCEDURES:

Eye Protection: As required by site-specific conditions. Not generally needed.

Skin Protection: None required.

Respiratory Protection: Not generally required unless needed to prevent respiratory irritation.

Ventilation: Use adequate ventilation to control exposure below recommended levels.

EFFECTS OF OVEREXPOSURE:

Eyes: Dust may cause mechanical irritation.

Skin: No known effect.

Inhalation: Dust may produce mechanical irritation to the mucous membranes of the nose, throat and upper respiratory tract.

Chronic: No anticipated chronic effects.

Existing health conditions affected by exposure: No known effects.

MATERIAL SAFETY DATA SHEET

AVM Drain Boards 2000, 2200, 6000, 6020, 9000, 9020, 9080, XL, 9900 & SWD Series

EMERGENCY AND FIRST AID PROCEDURES:

Eyes: Flush with water.
Skin: Rinse with water.
Inhalation: Remove from exposure.
Ingestion: N/A.

FIRE PROTECTION:

Flash Point (Method): Greater than 400 degrees (COC, ASTM D-92)
Fire Extinguishing Media: Dry chemical, foam, carbon dioxide.
Special Fire Fighting Procedures: For large fires in confined area use N10SH/MSHA

approved self-contained breathing apparatus: Use water fog or spray to exposed equipment and containers.

REACTIVITY DATA:

Stability: Stable
Incompatibility: None known
Hazardous Decomposition Products: Will not occur.
Hazardous Polymerization: Will not occur.

PHYSICAL DATA:

Physical State: Solid
Odor: Negligible
Viscosity: N/A
Solubility in Water: Negligible
Boiling Point: N/A

SPILL, LEAK & DISPOSAL INFORMATION:

Spill or Leak Procedures: Solid material, normal clean-up procedure.
Waste Disposal: Insure conformity with all applicable disposal regulations. Product does not meet the definition of hazardous waste.

STORAGE:

No special requirements for storage.

DETAIL #:
0580-AL_580-PL-0001
System
Aussie Mate 580-AL/580-PL

Backfilled Walls Overview



AVM AUSSIE MATE 580-AL/580-PL

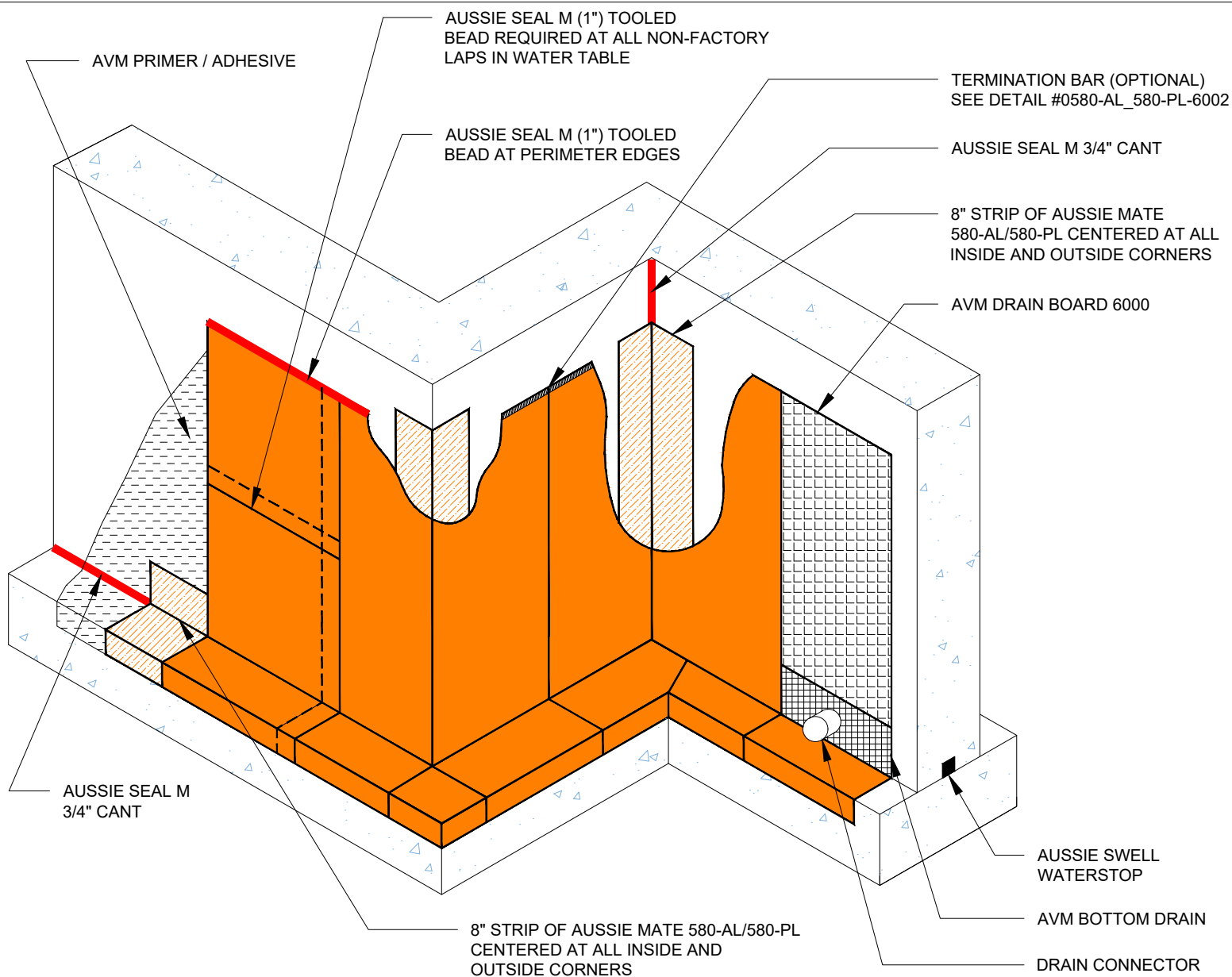

Notes:

1. Aussie Mate 580-AL is an LARR approved Waterproofing membrane and Methane Barrier.
2. Aussie Mate 580-AL is a heavy duty bituminous sheet membrane with aluminum protection layer for Below-Grade waterproofing applications that is available in a 60-mil or 80-mil thickness. Aussie Mate 580-AL may also be used as a methane and/or vapor barrier under horizontal slabs on grade.
3. Aussie Mate 580-PL is a 60-mil heavy duty bituminous sheet waterproofing membrane with a poly liner for below-grade waterproofing applications. Aussie Mate 580-PL cannot be used as a methane/vapor barrier in slab on grade applications.
4. **UV Exposure Limits:** Aussie Mate 580-AL - Up to 180 days. Aussie Mate 580-PL - Up to 30 days
5. See "Aussie Mate 580 Installation Instructions" for system requirements.

DETAIL #:
 0580-AL_580-PL-0002
 System:
 Aussie Mate 580-AL/580-PL

Backfilled Wall with Vapor Barrier Under Slab



AVM AUSSIE MATE 580-AL/580-PL

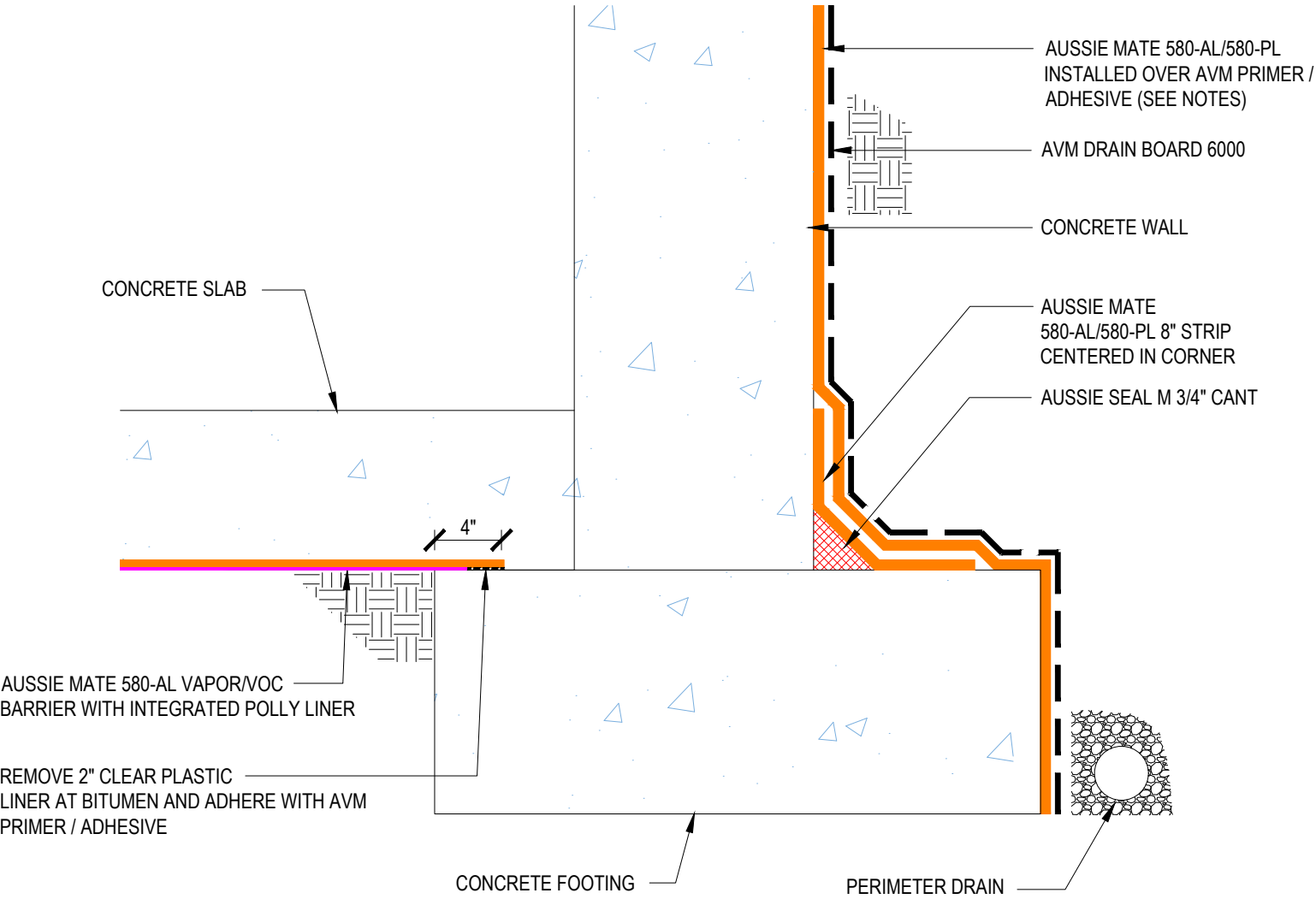

Notes:

1. Aussie Mate 580-AL is an LARR approved Waterproofing membrane and Methane Barrier.
2. Aussie Mate 580-AL is a heavy duty bituminous sheet membrane with aluminum protection layer for Below-Grade waterproofing applications that is available in a 60-mil or 80-mil thickness. Aussie Mate 580-AL may also be used as a methane and/or vapor barrier under horizontal slabs on grade.
3. Aussie Mate 580-PL is a 60-mil heavy duty bituminous sheet waterproofing membrane with a poly liner for below-grade waterproofing applications. Aussie Mate 580-PL cannot be used as a methane/vapor barrier in slab on grade applications.
4. **UV Exposure Limits:** Aussie Mate 580-AL - Up to 180 days. Aussie Mate 580-PL - Up to 30 days
5. See "Aussie Mate 580 Installation Instructions" for system requirements.

DETAIL #:
 0580-AL_580-PL-0004
 System:
 Aussie Mate 580-AL/580-PL

Transition to Vapor Barrier Flush Footing



AVM AUSSIE MATE 580-AL/580-PL

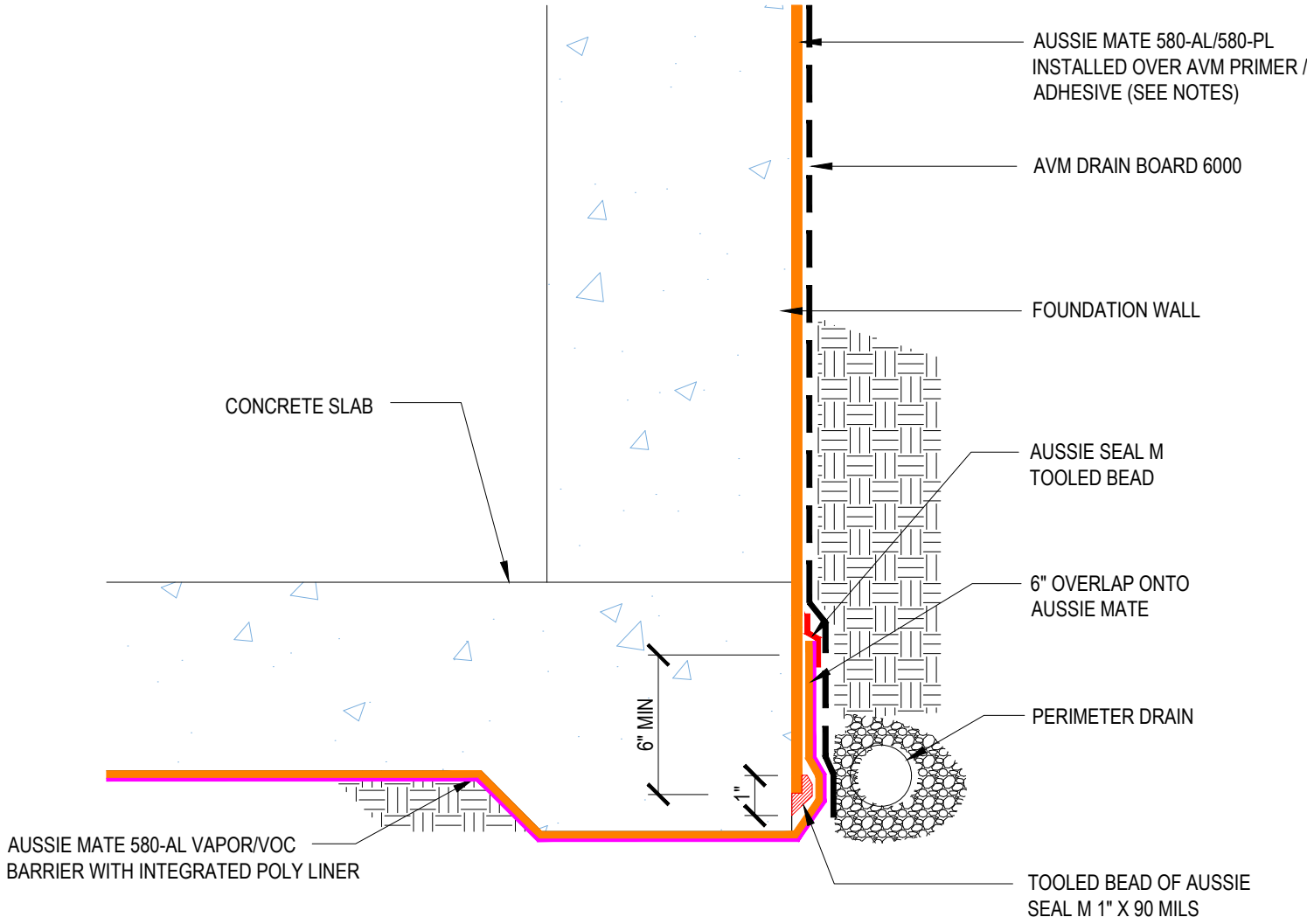

Notes:

1. Aussie Mate 580-AL is an LARR approved Waterproofing membrane and Methane Barrier.
2. Aussie Mate 580-AL is a heavy duty bituminous sheet membrane with aluminum protection layer for Below-Grade waterproofing applications that is available in a 60-mil or 80-mil thickness. Aussie Mate 580-AL may also be used as a methane and/or vapor barrier under horizontal slabs on grade.
3. Aussie Mate 580-PL is a 60-mil heavy duty bituminous sheet waterproofing membrane with a poly liner for below-grade waterproofing applications. Aussie Mate 580-PL cannot be used as a methane/vapor barrier in slab on grade applications.
4. **UV Exposure Limits:** Aussie Mate 580-AL - Up to 180 days. Aussie Mate 580-PL - Up to 30 days
5. See "Aussie Mate 580 Installation Instructions" for system requirements.

DETAIL #:
 0580-AL_580-PL-0006
 System:
 Aussie Mate 580-AL/580-PL

Transition to Aussie Skin Flush Footing



AVM AUSSIE MATE 580-AL/580-PL

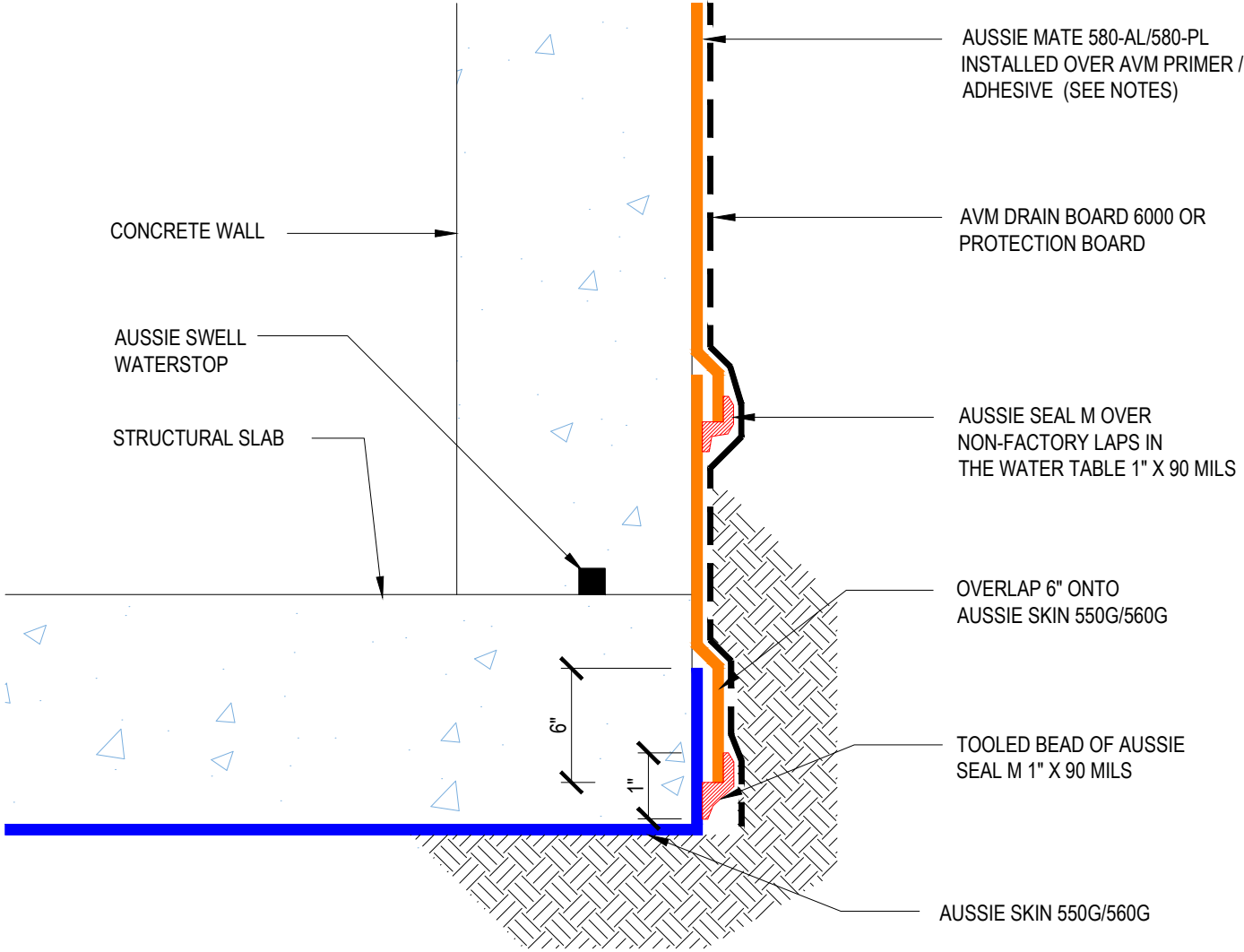

Notes:

1. Aussie Mate 580-AL is an LARR approved Waterproofing membrane and Methane Barrier.
2. Aussie Mate 580-AL is a heavy duty bituminous sheet membrane with aluminum protection layer for Below-Grade waterproofing applications that is available in a 60-mil or 80-mil thickness. Aussie Mate 580-AL may also be used as a methane and/or vapor barrier under horizontal slabs on grade.
3. Aussie Mate 580-PL is a 60-mil heavy duty bituminous sheet waterproofing membrane with a poly liner for below-grade waterproofing applications. Aussie Mate 580-PL cannot be used as a methane/vapor barrier in slab on grade applications.
4. **UV Exposure Limits:** Aussie Mate 580-AL - Up to 180 days. Aussie Mate 580-PL - Up to 30 days
5. See "Aussie Mate 580 Installation Instructions" for system requirements.

DETAIL #:
 0580-AL_580-PL-0102
 System:
 Aussie Mate 580-AL/580-PL

Elevator Pit Transition to Aussie Skin 550G/560G Extended Footing



AVM AUSSIE MATE 580-AL/580-PL

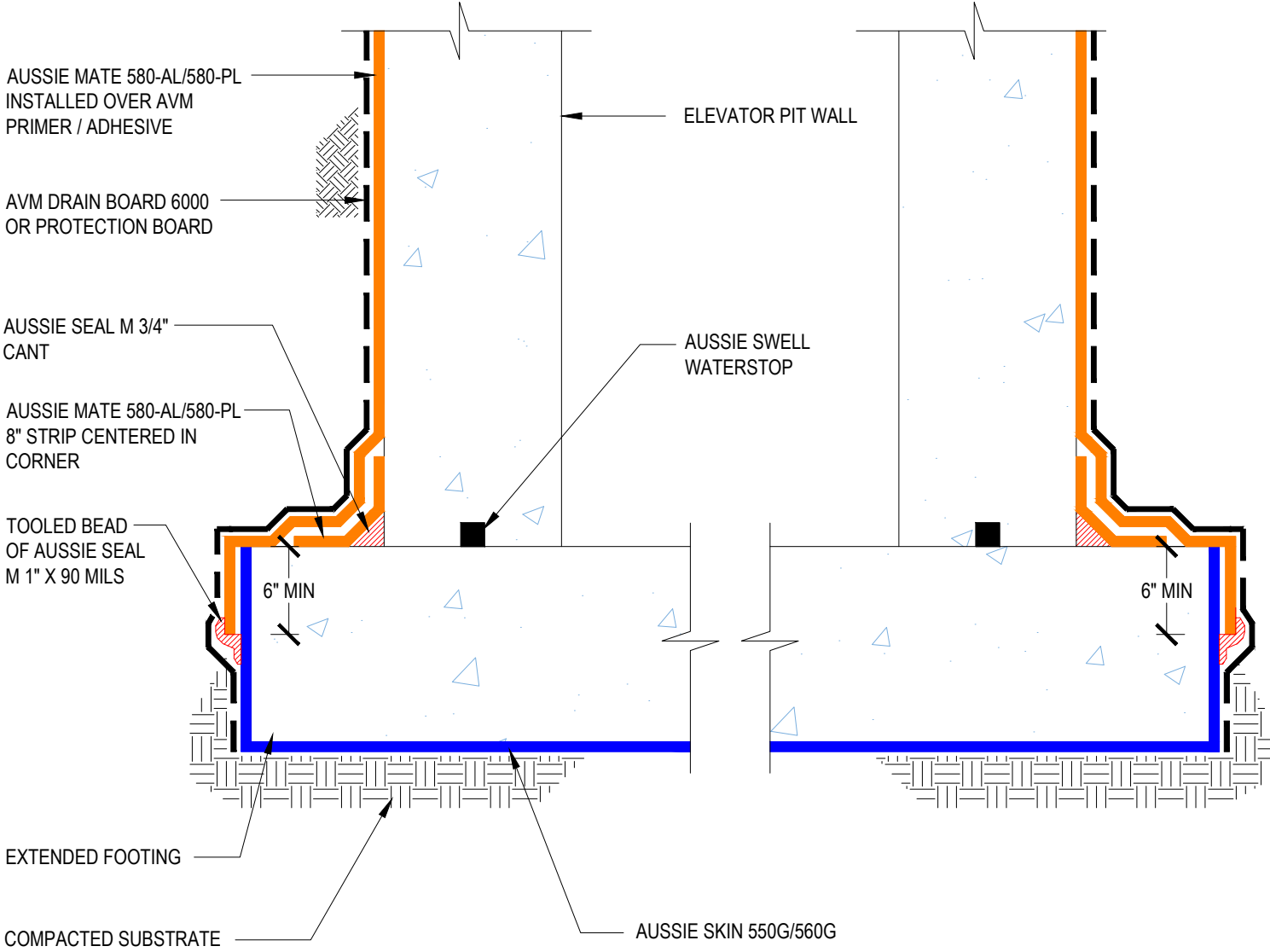

Notes:

1. Aussie Mate 580-AL is an LARR approved Waterproofing membrane and Methane Barrier.
2. Aussie Mate 580-AL is a heavy duty bituminous sheet membrane with aluminum protection layer for Below-Grade waterproofing applications that is available in a 60-mil or 80-mil thickness. Aussie Mate 580-AL may also be used as a methane and/or vapor barrier under horizontal slabs on grade.
3. Aussie Mate 580-PL is a 60-mil heavy duty bituminous sheet waterproofing membrane with a poly liner for below-grade waterproofing applications. Aussie Mate 580-PL cannot be used as a methane/vapor barrier in slab on grade applications.
4. **UV Exposure Limits:** Aussie Mate 580-AL - Up to 180 days. Aussie Mate 580-PL - Up to 30 days
5. See "Aussie Mate 580 Installation Instructions" for system requirements.

DETAIL #:
 0580-AL_580-PL-0104
 System:
 Aussie Mate 580-AL/580-PL

Elevator Pit Transition to Aussie Skin 550G/560G Flush Footing



AVM AUSSIE MATE 580-AL/580-PL

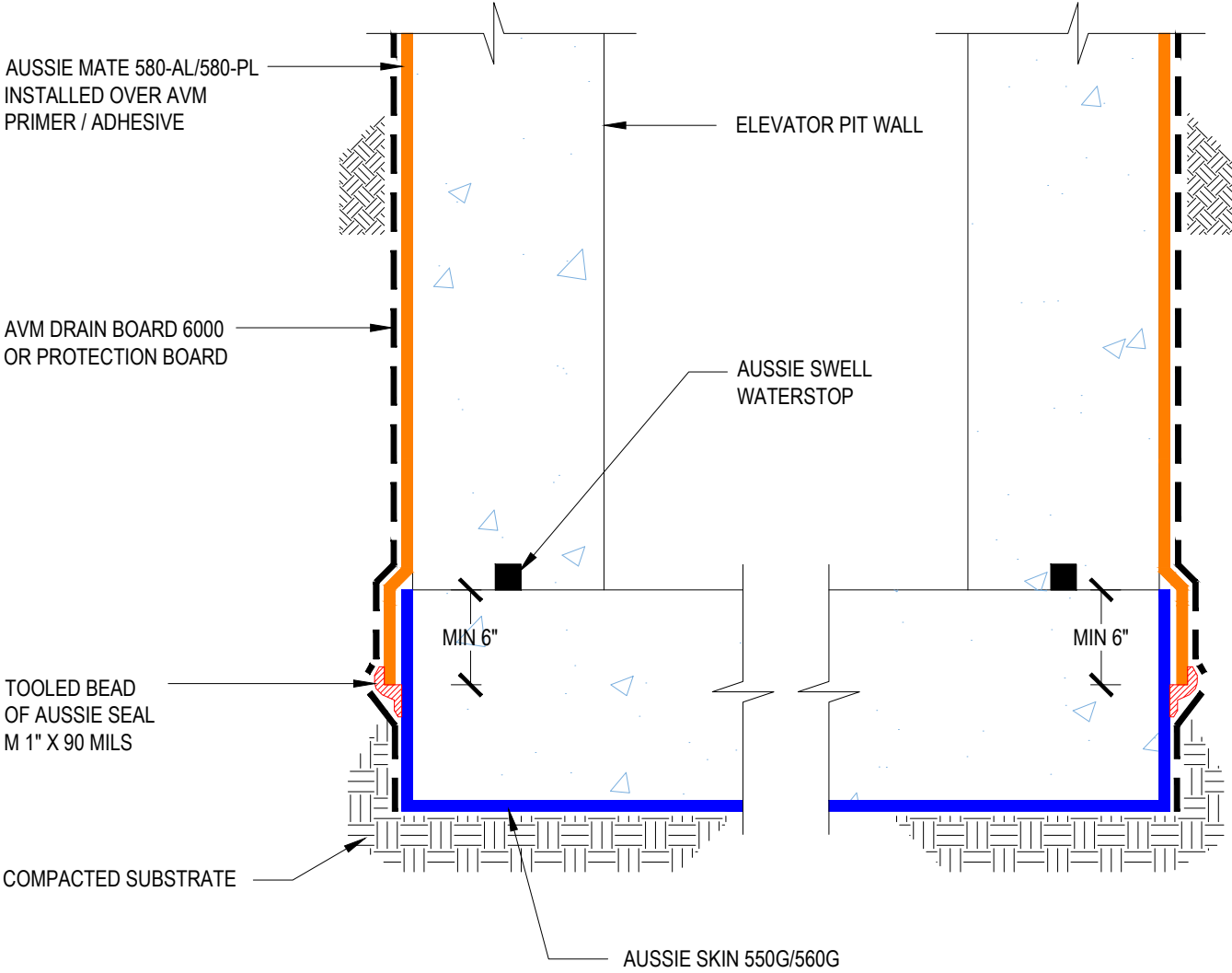

Notes:

1. Aussie Mate 580-AL is an LARR approved Waterproofing membrane and Methane Barrier.
2. Aussie Mate 580-AL is a heavy duty bituminous sheet membrane with aluminum protection layer for Below-Grade waterproofing applications that is available in a 60-mil or 80-mil thickness. Aussie Mate 580-AL may also be used as a methane and/or vapor barrier under horizontal slabs on grade.
3. Aussie Mate 580-PL is a 60-mil heavy duty bituminous sheet waterproofing membrane with a poly liner for below-grade waterproofing applications. Aussie Mate 580-PL cannot be used as a methane/vapor barrier in slab on grade applications.
4. **UV Exposure Limits:** Aussie Mate 580-AL - Up to 180 days. Aussie Mate 580-PL - Up to 30 days
5. See "Aussie Mate 580 Installation Instructions" for system requirements.

DETAIL #:
0580-AL_580-PL-1102
 AVM System 580
Aussie Mate 580-AL/580-PL

Deck to Wall Transition



AVM AUSSIE MATE 580-AL/580-PL

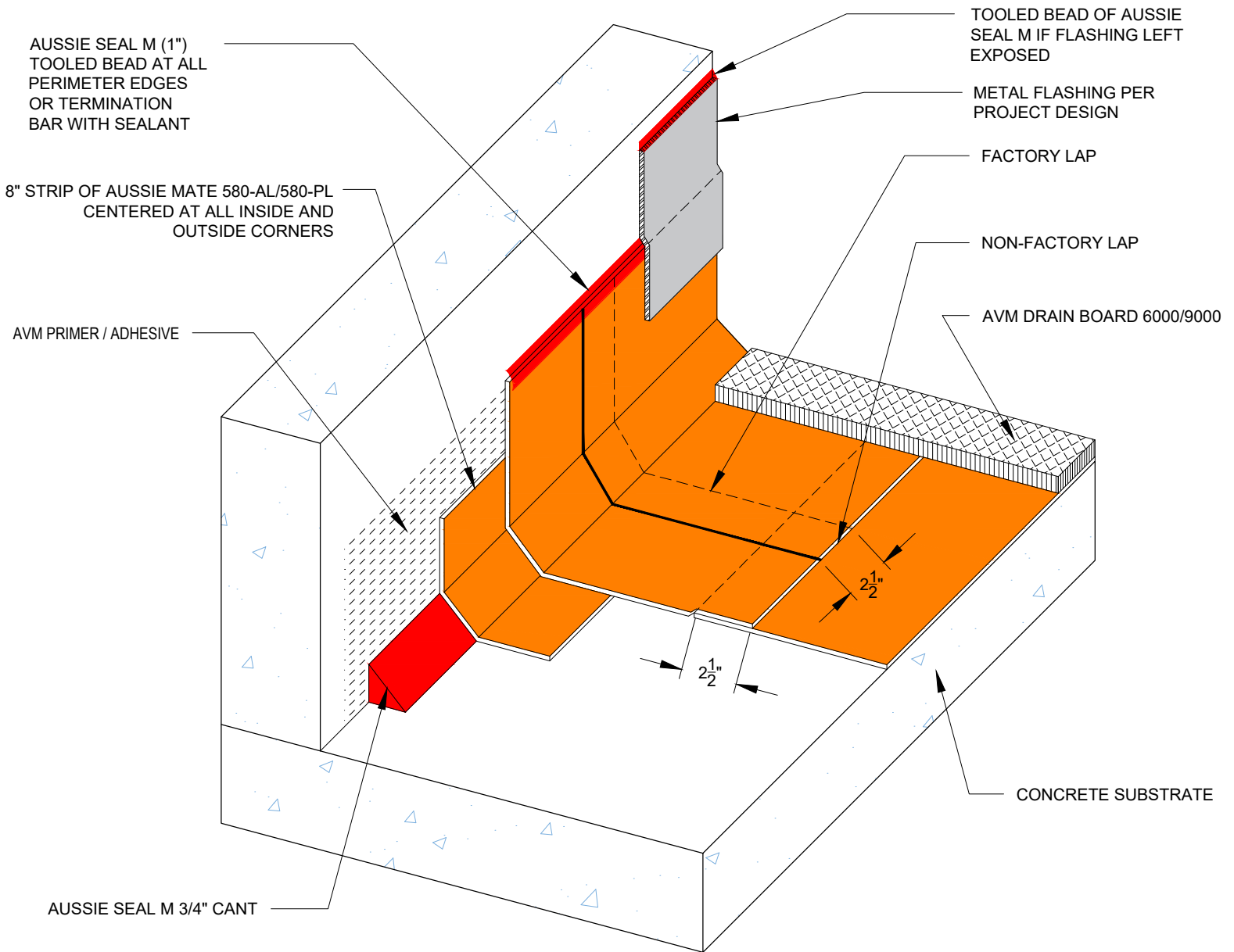

Notes:

1. Aussie Mate 580-AL is an LARR approved Waterproofing membrane and Methane Barrier.
2. Aussie Mate 580-AL is a heavy duty bituminous sheet membrane with aluminum protection layer for Below-Grade waterproofing applications that is available in a 60-mil or 80-mil thickness. Aussie Mate 580-AL may also be used as a methane and/or vapor barrier under horizontal slabs on grade.
3. Aussie Mate 580-PL is a 60-mil heavy duty bituminous sheet waterproofing membrane with a poly liner for below-grade waterproofing applications. Aussie Mate 580-PL cannot be used as a methane/vapor barrier in slab on grade applications.
4. **UV Exposure Limits:** Aussie Mate 580-AL - Up to 180 days. Aussie Mate 580-PL - Up to 30 days
5. See "Aussie Mate 580 Installation Instructions" for system requirements.

DETAIL #:
 0580-AL_580-PL-1104
 System:
 Aussie Mate 580-AL/580-PL

Deck to Wall Transition



AVM AUSSIE MATE 580-AL/580-PL

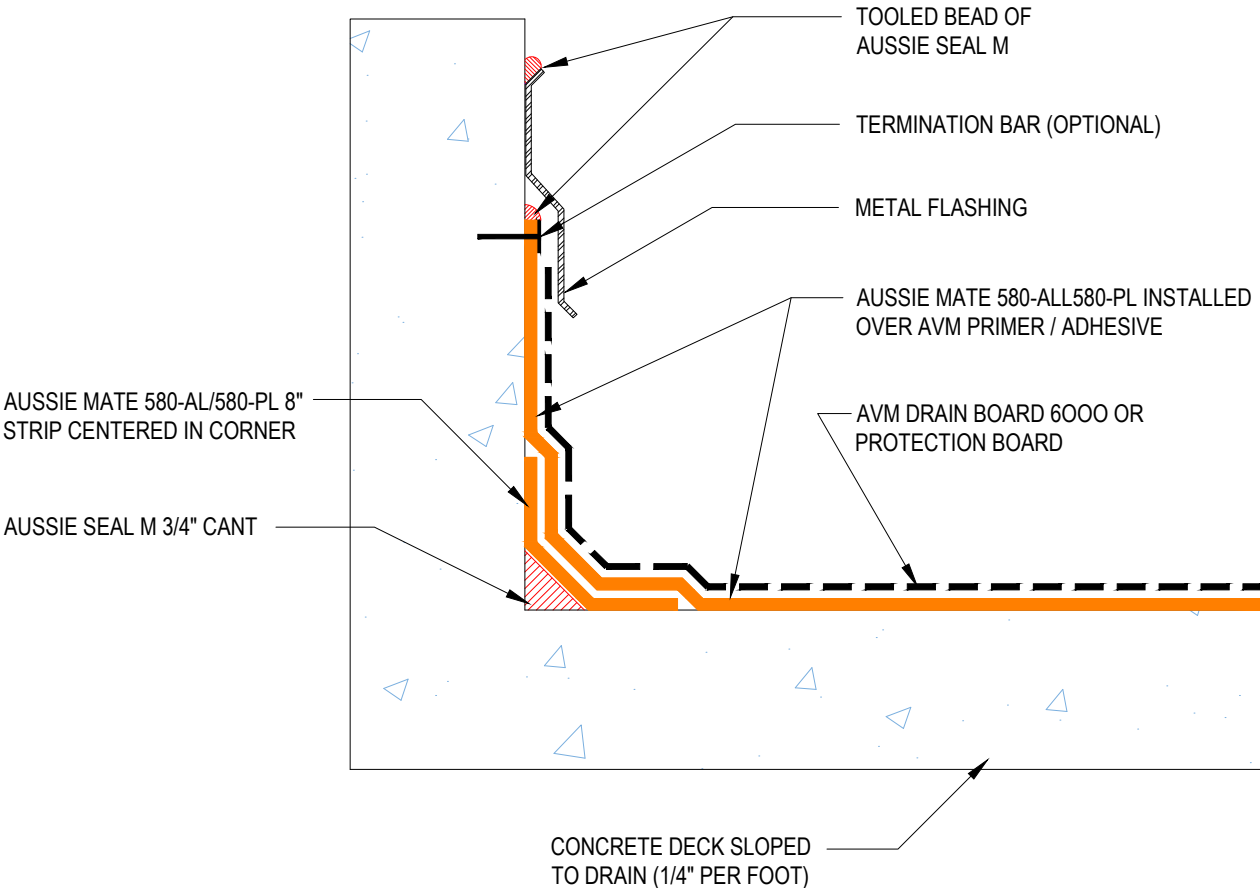

Notes:

1. Aussie Mate 580-AL is an LARR approved Waterproofing membrane and Methane Barrier.
2. Aussie Mate 580-AL is a heavy duty bituminous sheet membrane with aluminum protection layer for Below-Grade waterproofing applications that is available in a 60-mil or 80-mil thickness. Aussie Mate 580-AL may also be used as a methane and/or vapor barrier under horizontal slabs on grade.
3. Aussie Mate 580-PL is a 60-mil heavy duty bituminous sheet waterproofing membrane with a poly liner for below-grade waterproofing applications. Aussie Mate 580-PL cannot be used as a methane/vapor barrier in slab on grade applications.
4. **UV Exposure Limits:** Aussie Mate 580-AL - Up to 180 days. Aussie Mate 580-PL - Up to 30 days
5. See "Aussie Mate 580 Installation Instructions" for system requirements.

DETAIL #:	0580-AL_580-PL-1106
System:	Aussie Mate 580-AL/580-PL

Split Slab Assembly



AVM AUSSIE MATE 580-AL/580-PL

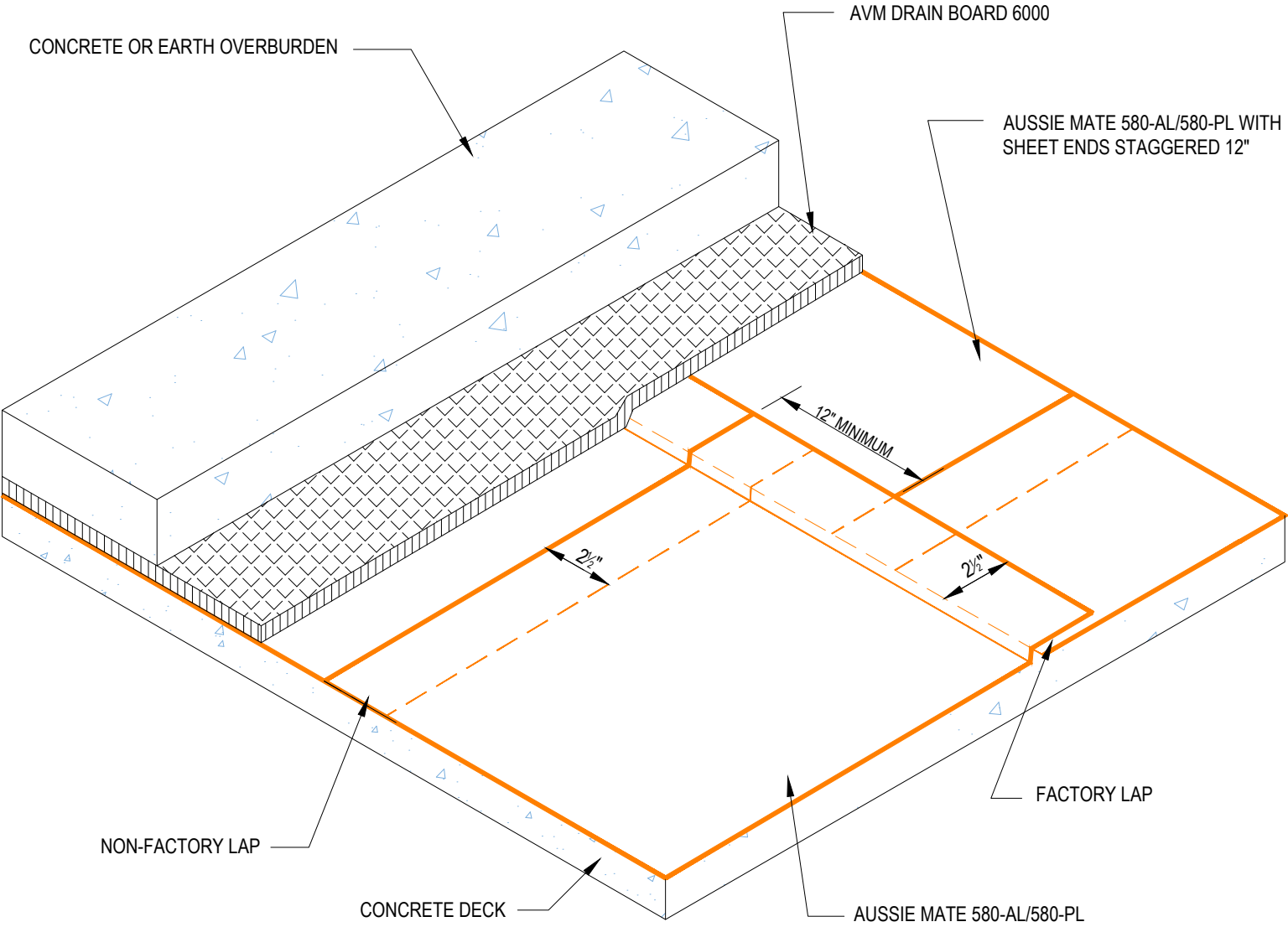

Notes:

1. Aussie Mate 580-AL is an LARR approved Waterproofing membrane and Methane Barrier.
2. Aussie Mate 580-AL is a heavy duty bituminous sheet membrane with aluminum protection layer for Below-Grade waterproofing applications that is available in a 60-mil or 80-mil thickness. Aussie Mate 580-AL may also be used as a methane and/or vapor barrier under horizontal slabs on grade.
3. Aussie Mate 580-PL is a 60-mil heavy duty bituminous sheet waterproofing membrane with a poly liner for below-grade waterproofing applications. Aussie Mate 580-PL cannot be used as a methane/vapor barrier in slab on grade applications.
4. **UV Exposure Limits:** Aussie Mate 580-AL - Up to 180 days. Aussie Mate 580-PL - Up to 30 days
5. See "Aussie Mate 580 Installation Instructions" for system requirements.

DETAIL #:
0580-AL_580-PL-1108
System:
Aussie Mate 580-AL/580-PL

Split Slab Edge Termination



AVM AUSSIE MATE 580-AL/580-PL

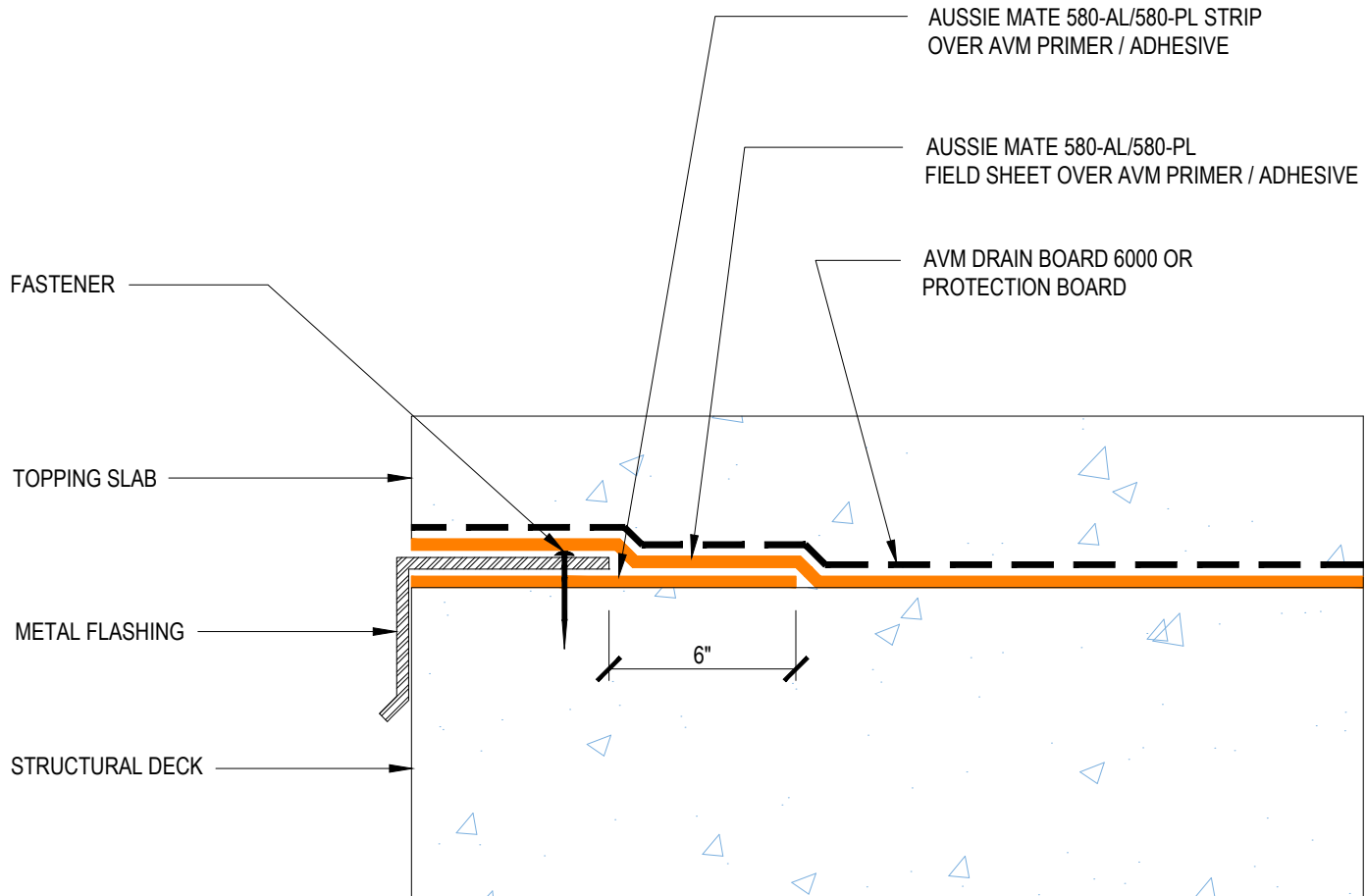

Notes:

1. Aussie Mate 580-AL is an LARR approved Waterproofing membrane and Methane Barrier.
2. Aussie Mate 580-AL is a heavy duty bituminous sheet membrane with aluminum protection layer for Below-Grade waterproofing applications that is available in a 60-mil or 80-mil thickness. Aussie Mate 580-AL may also be used as a methane and/or vapor barrier under horizontal slabs on grade.
3. Aussie Mate 580-PL is a 60-mil heavy duty bituminous sheet waterproofing membrane with a poly liner for below-grade waterproofing applications. Aussie Mate 580-PL cannot be used as a methane/vapor barrier in slab on grade applications.
4. **UV Exposure Limits:** Aussie Mate 580-AL - Up to 180 days. Aussie Mate 580-PL - Up to 30 days
5. See "Aussie Mate 580 Installation Instructions" for system requirements.

DETAIL #:
0580-AL_580-PL-1200
System:
Aussie Mate 580-AL/580-PL

Control Joint Detailing

AUSSIE MATE 580-AL/580-PL

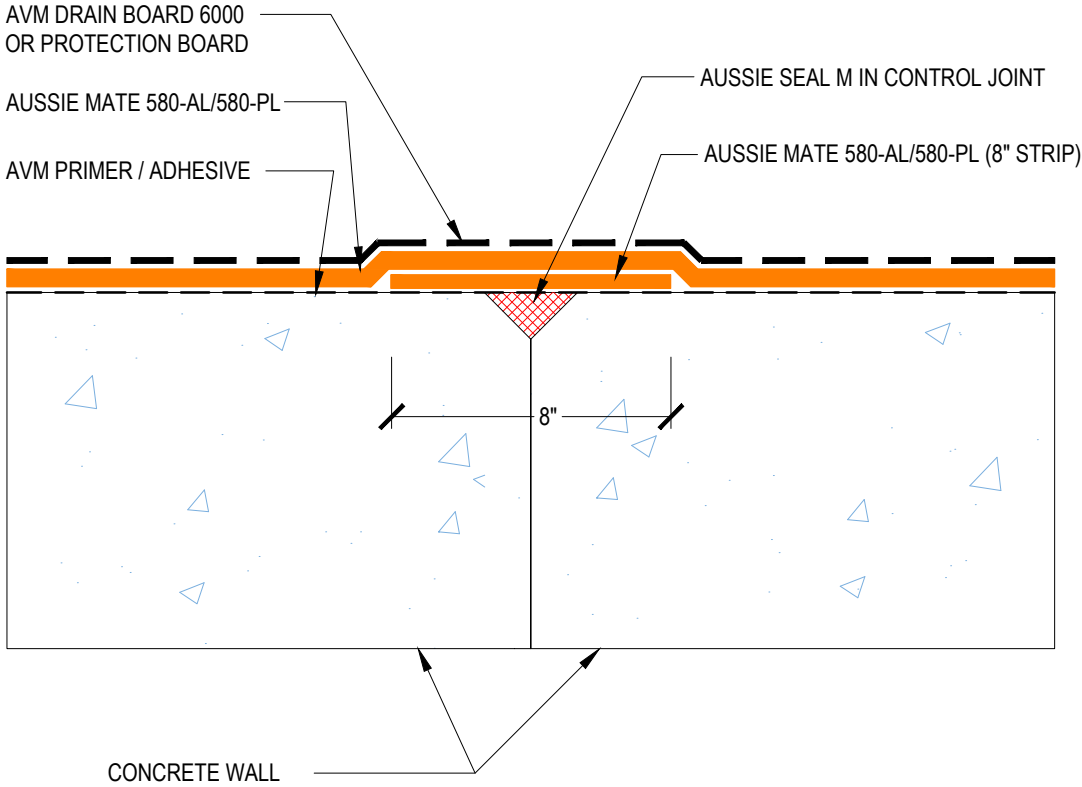

PLAN VIEW

Notes:

- 1. Aussie Mate 580-AL is an LARR approved Waterproofing membrane and Methane Barrier.
- 2. Aussie Mate 580-AL is a heavy duty bituminous sheet membrane with aluminum protection layer for Below-Grade waterproofing applications that is available in a 60-mil or 80-mil thickness. Aussie Mate 580-AL may also be used as a methane and/or vapor barrier under horizontal slabs on grade.
- 3. Aussie Mate 580-PL is a 60-mil heavy duty bituminous sheet waterproofing membrane with a poly liner for below-grade waterproofing applications. Aussie Mate 580-PL cannot be used as a methane/vapor barrier in slab on grade applications.
- 4. **UV Exposure Limits:** Aussie Mate 580-AL - Up to 180 days. Aussie Mate 580-PL - Up to 30 days
- 5. See "Aussie Mate 580 Installation Instructions" for system requirements.

DETAIL #:
0580-AL_580-PL-1504
System:
Aussie Mate 580-AL/580-PL

Deck Drain - Flush



AVM AUSSIE MATE 580-AL/580-PL

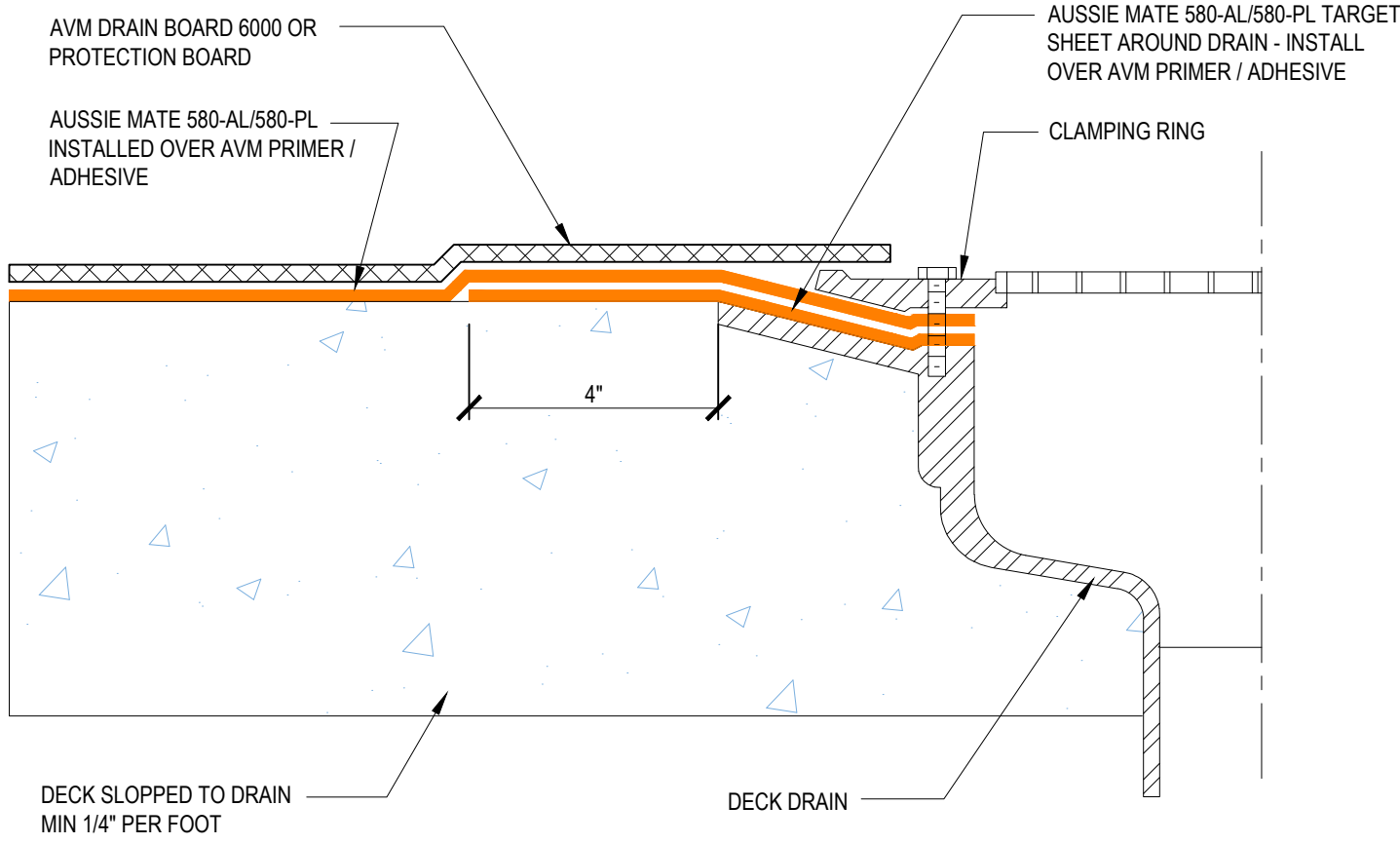

Notes:

- 1. Aussie Mate 580-AL is an LARR approved Waterproofing membrane and Methane Barrier.
- 2. Aussie Mate 580-AL is a heavy duty bituminous sheet membrane with aluminum protection layer for Below-Grade waterproofing applications that is available in a 60-mil or 80-mil thickness. Aussie Mate 580-AL may also be used as a methane and/or vapor barrier under horizontal slabs on grade.
- 3. Aussie Mate 580-PL is a 60-mil heavy duty bituminous sheet waterproofing membrane with a poly liner for below-grade waterproofing applications. Aussie Mate 580-PL cannot be used as a methane/vapor barrier in slab on grade applications.
- 4. **UV Exposure Limits:** Aussie Mate 580-AL - Up to 180 days. Aussie Mate 580-PL - Up to 30 days
- 5. See "Aussie Mate 580 Installation Instructions" for system requirements.

DETAIL #:
 0580-AL_580-PL-1506
 System:
 Aussie Mate 580-AL/580-PL

Deck Drain with Inspection Cover



AVM AUSSIE MATE 580-AL/580-PL

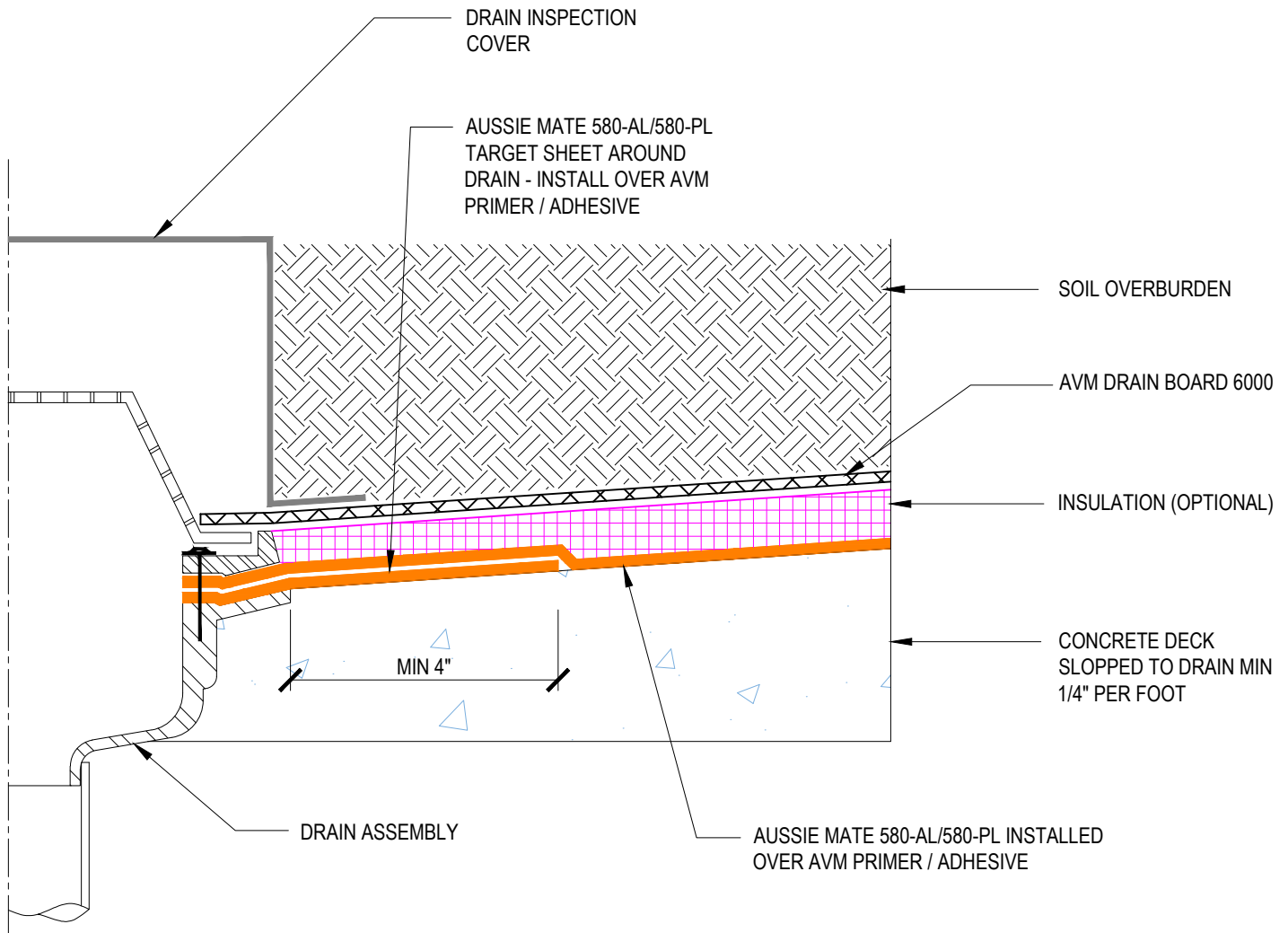

Notes:

1. Aussie Mate 580-AL is an LARR approved Waterproofing membrane and Methane Barrier.
2. Aussie Mate 580-AL is a heavy duty bituminous sheet membrane with aluminum protection layer for Below-Grade waterproofing applications that is available in a 60-mil or 80-mil thickness. Aussie Mate 580-AL may also be used as a methane and/or vapor barrier under horizontal slabs on grade.
3. Aussie Mate 580-PL is a 60-mil heavy duty bituminous sheet waterproofing membrane with a poly liner for below-grade waterproofing applications. Aussie Mate 580-PL cannot be used as a methane/vapor barrier in slab on grade applications.
4. **UV Exposure Limits:** Aussie Mate 580-AL - Up to 180 days. Aussie Mate 580-PL - Up to 30 days
5. See "Aussie Mate 580 Installation Instructions" for system requirements.

DETAIL #:
0580-AL_580-PL-1508
System:
Aussie Mate 580-AL/580-PL

Split Slab Two-Stage Drain



AVM AUSSIE MATE 580-AL/580-PL

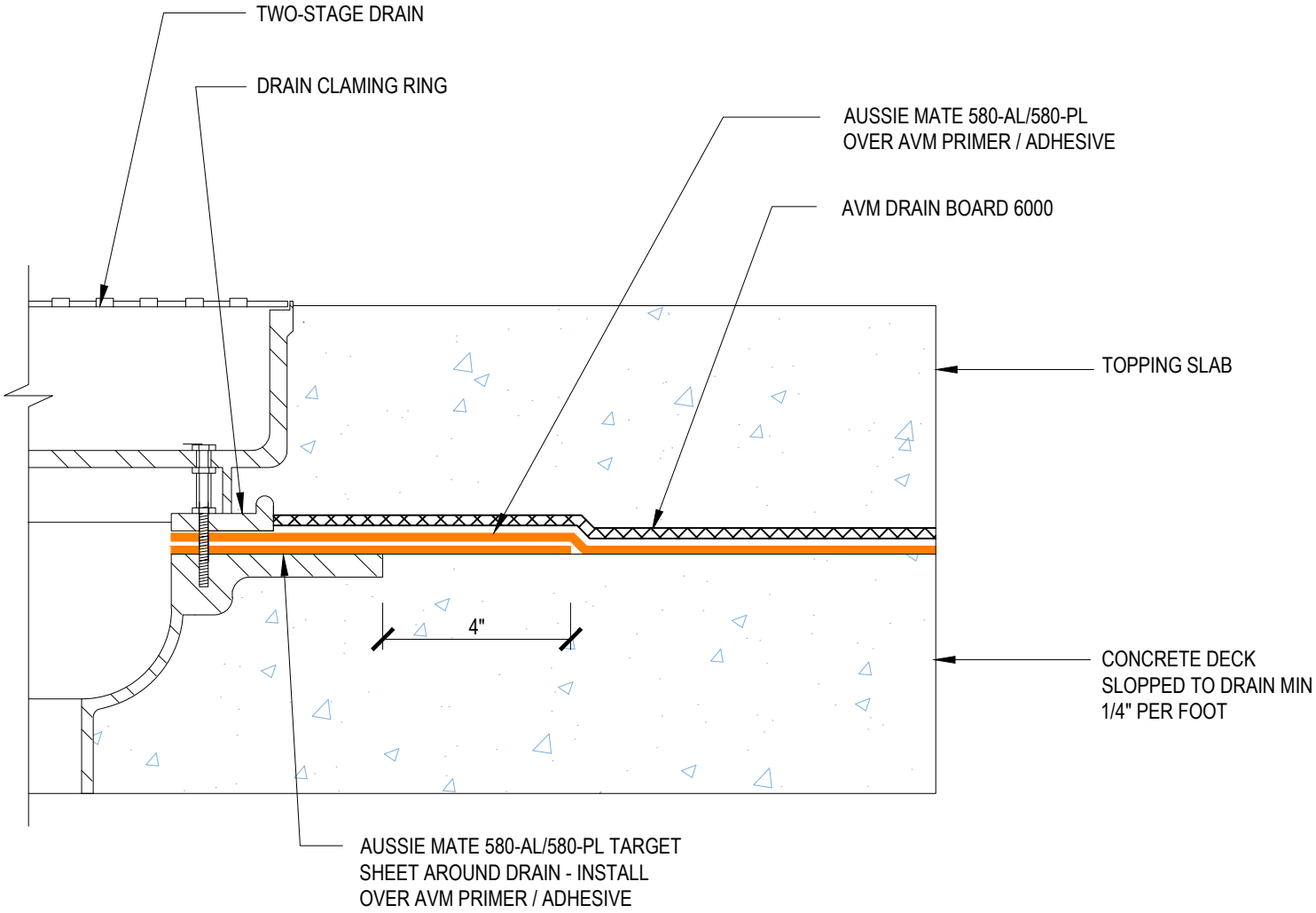

Notes:

- 1. Aussie Mate 580-AL is an LARR approved Waterproofing membrane and Methane Barrier.
- 2. Aussie Mate 580-AL is a heavy duty bituminous sheet membrane with aluminum protection layer for Below-Grade waterproofing applications that is available in a 60-mil or 80-mil thickness. Aussie Mate 580-AL may also be used as a methane and/or vapor barrier under horizontal slabs on grade.
- 3. Aussie Mate 580-PL is a 60-mil heavy duty bituminous sheet waterproofing membrane with a poly liner for below-grade waterproofing applications. Aussie Mate 580-PL cannot be used as a methane/vapor barrier in slab on grade applications.
- 4. **UV Exposure Limits:** Aussie Mate 580-AL - Up to 180 days. Aussie Mate 580-PL - Up to 30 days
- 5. See "Aussie Mate 580 Installation Instructions" for system requirements.

DETAIL #:
 0580-AL_580-PL-6002
 System:
 Aussie Mate 580-AL/580-PL

Planter Terminations



AVM AUSSIE MATE 580-AL/580-PL

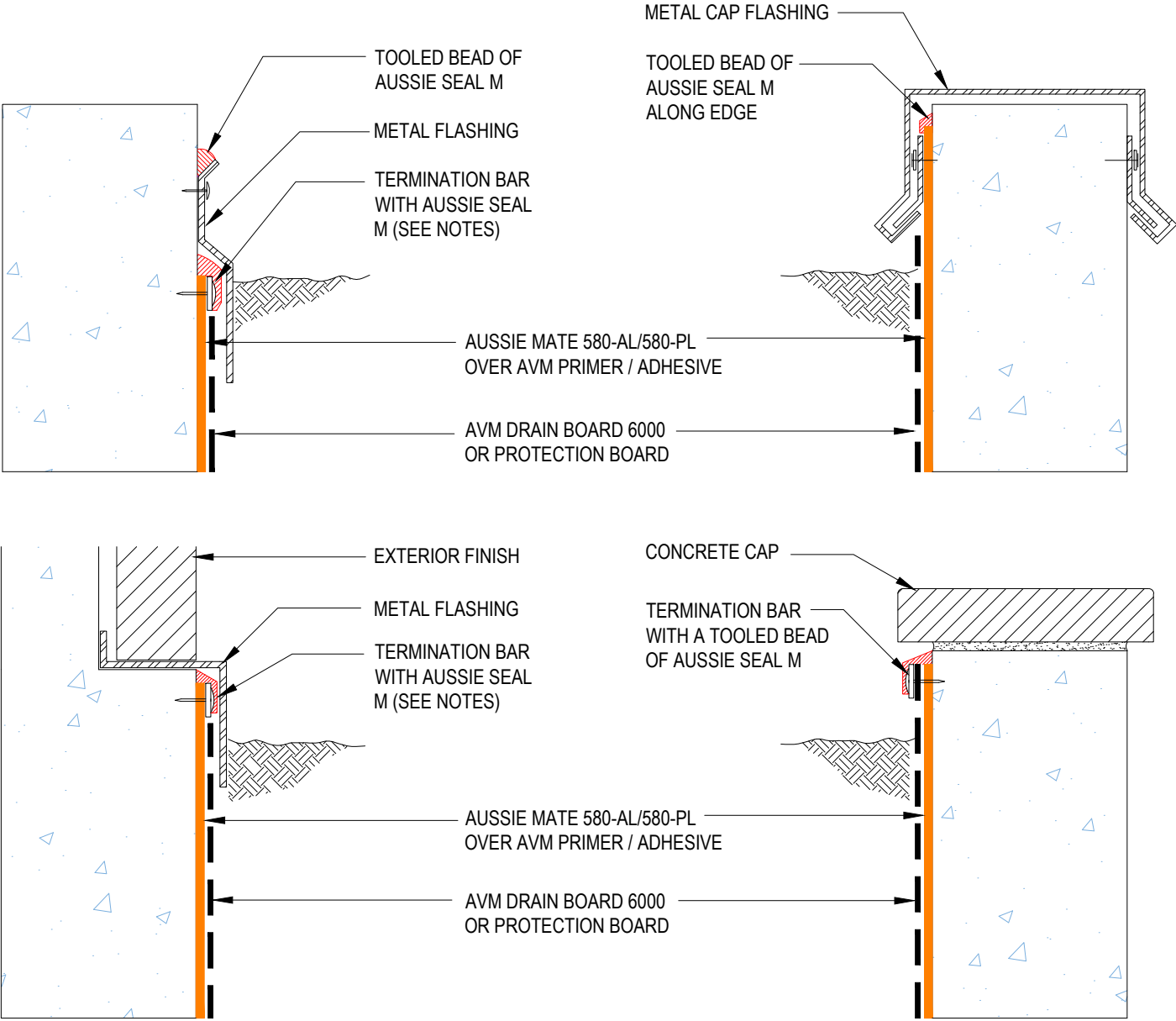

Notes:

1. Aussie Mate 580-AL is an LARR approved Waterproofing membrane and Methane Barrier.
2. Aussie Mate 580-AL is a heavy duty bituminous sheet membrane with aluminum protection layer for Below-Grade waterproofing applications that is available in a 60-mil or 80-mil thickness. Aussie Mate 580-AL may also be used as a methane and/or vapor barrier under horizontal slabs on grade.
3. Aussie Mate 580-PL is a 60-mil heavy duty bituminous sheet waterproofing membrane with a poly liner for below-grade waterproofing applications. Aussie Mate 580-PL cannot be used as a methane/vapor barrier in slab on grade applications.
4. **UV Exposure Limits:** Aussie Mate 580-AL - Up to 180 days. Aussie Mate 580-PL - Up to 30 days
5. See "Aussie Mate 580 Installation Instructions" for system requirements.

DETAIL #: 0580-AL_580-PL-6004
System: Aussie Mate 580-AL/580-PL

Sidewalk Termination



AVM AUSSIE MATE 580-AL/580-PL

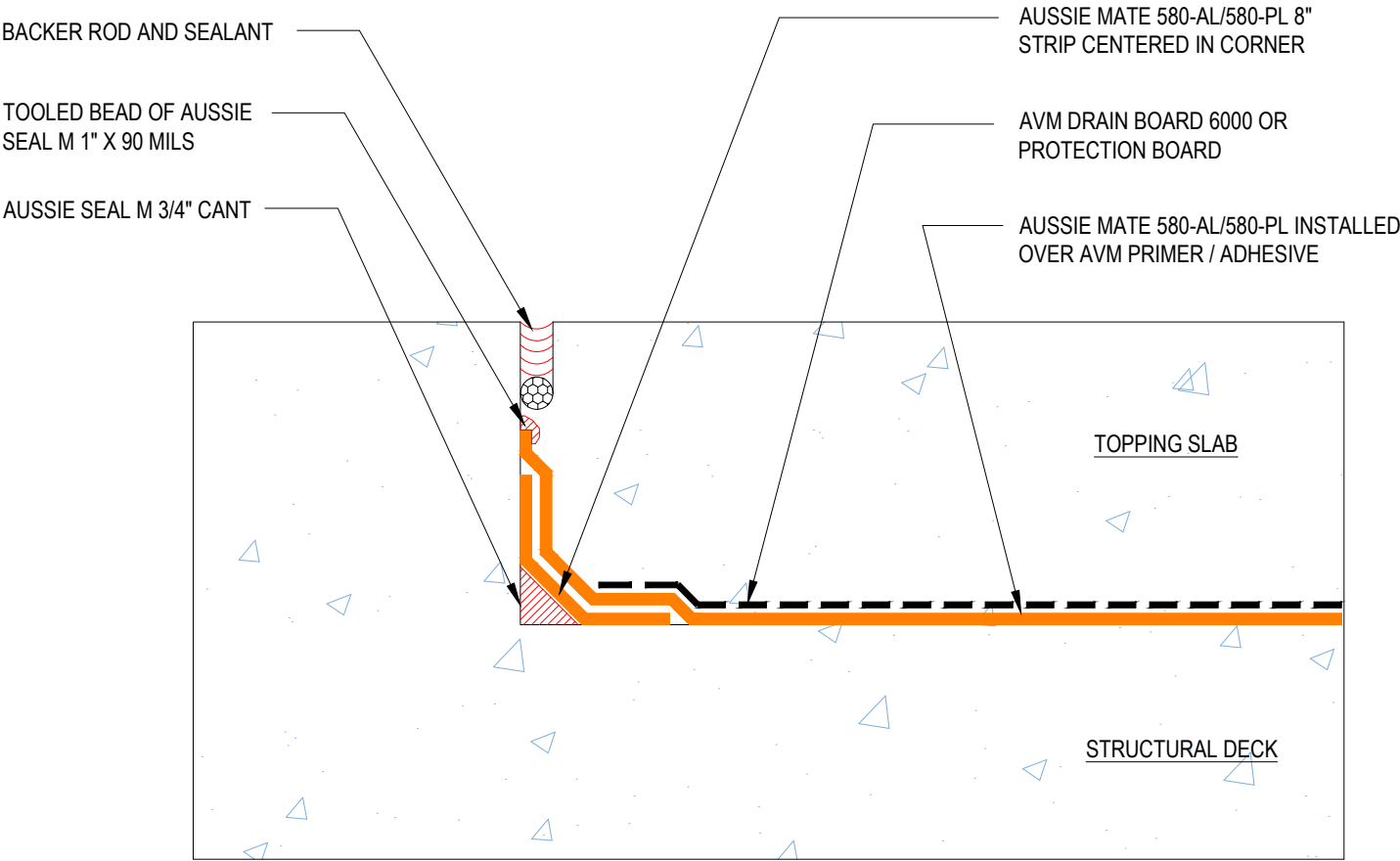

Notes:

1. Aussie Mate 580-AL is an LARR approved Waterproofing membrane and Methane Barrier.
2. Aussie Mate 580-AL is a heavy duty bituminous sheet membrane with aluminum protection layer for Below-Grade waterproofing applications that is available in a 60-mil or 80-mil thickness. Aussie Mate 580-AL may also be used as a methane and/or vapor barrier under horizontal slabs on grade.
3. Aussie Mate 580-PL is a 60-mil heavy duty bituminous sheet waterproofing membrane with a poly liner for below-grade waterproofing applications. Aussie Mate 580-PL cannot be used as a methane/vapor barrier in slab on grade applications.
4. **UV Exposure Limits:** Aussie Mate 580-AL - Up to 180 days. Aussie Mate 580-PL - Up to 30 days
5. See "Aussie Mate 580 Installation Instructions" for system requirements.

DETAIL #:
 0580-AL_580-PL-6006
 System:
 Aussie Mate 580-AL/580-PL

Backfilled Wall Terminations



AVM AUSSIE MATE 580-AL/580-PL

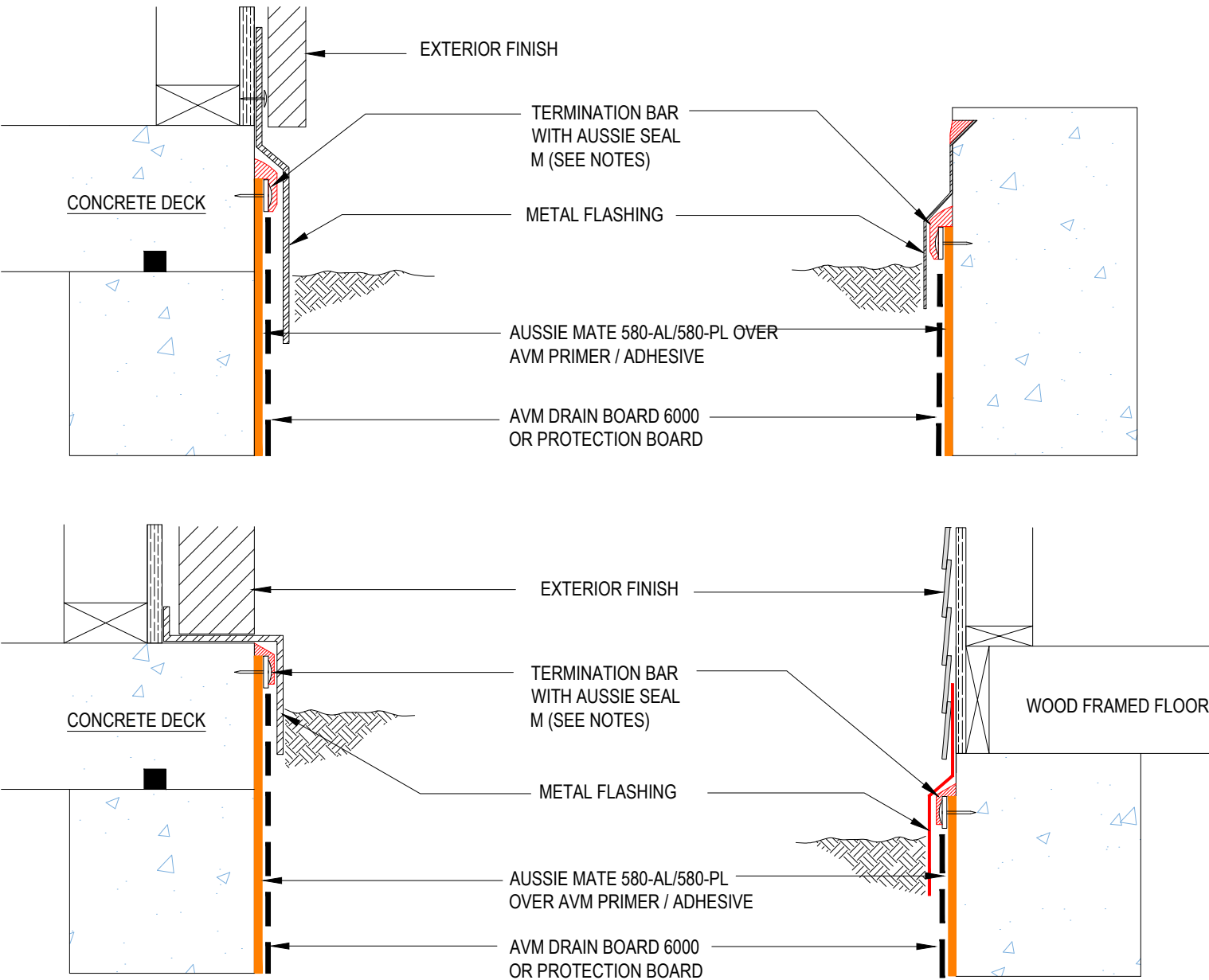

Notes:

1. Aussie Mate 580-AL is an LARR approved Waterproofing membrane and Methane Barrier.
2. Aussie Mate 580-AL is a heavy duty bituminous sheet membrane with aluminum protection layer for Below-Grade waterproofing applications that is available in a 60-mil or 80-mil thickness. Aussie Mate 580-AL may also be used as a methane and/or vapor barrier under horizontal slabs on grade.
3. Aussie Mate 580-PL is a 60-mil heavy duty bituminous sheet waterproofing membrane with a poly liner for below-grade waterproofing applications. Aussie Mate 580-PL cannot be used as a methane/vapor barrier in slab on grade applications.
4. **UV Exposure Limits:** Aussie Mate 580-AL - Up to 180 days. Aussie Mate 580-PL - Up to 30 days
5. See "Aussie Mate 580 Installation Instructions" for system requirements.

DETAIL #:
 0580-AL_580-PL-6502
 System:
 Aussie Mate 580-AL/580-PL

Typical Wall Penetration



AVM AUSSIE MATE 580-AL/580-PL

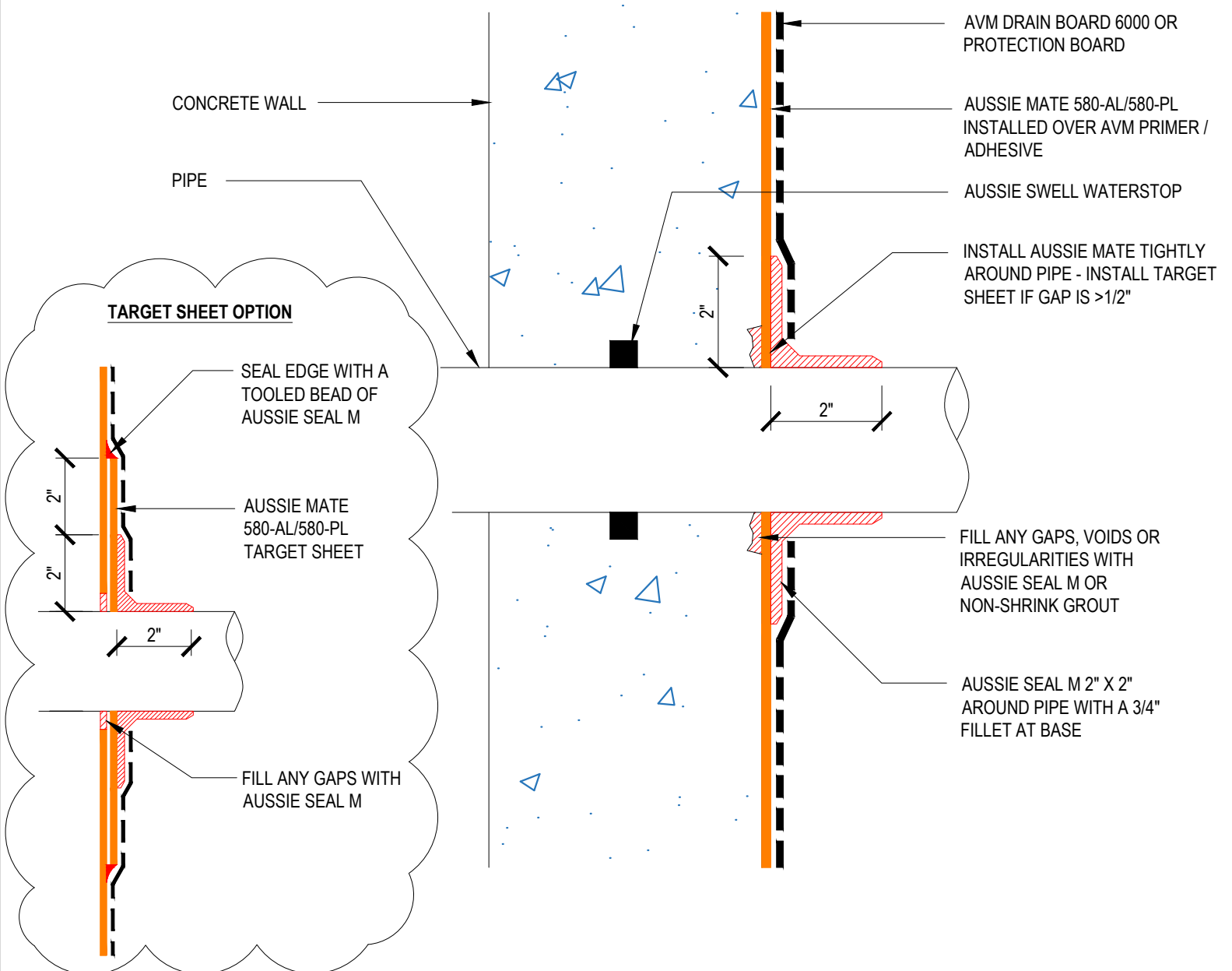

Notes:

1. Aussie Mate 580-AL is an LARR approved Waterproofing membrane and Methane Barrier.
2. Aussie Mate 580-AL is a heavy duty bituminous sheet membrane with aluminum protection layer for Below-Grade waterproofing applications that is available in a 60-mil or 80-mil thickness. Aussie Mate 580-AL may also be used as a methane and/or vapor barrier under horizontal slabs on grade.
3. Aussie Mate 580-PL is a 60-mil heavy duty bituminous sheet waterproofing membrane with a poly liner for below-grade waterproofing applications. Aussie Mate 580-PL cannot be used as a methane/vapor barrier in slab on grade applications.
4. **UV Exposure Limits:** Aussie Mate 580-AL - Up to 180 days. Aussie Mate 580-PL - Up to 30 days
5. See "Aussie Mate 580 Installation Instructions" for system requirements.

DETAIL #:
 0580-AL_580-PL-6504
 System:
 Aussie Mate 580-AL/580-PL

Cored Wall Penetration



AVM AUSSIE MATE 580-AL/580-PL

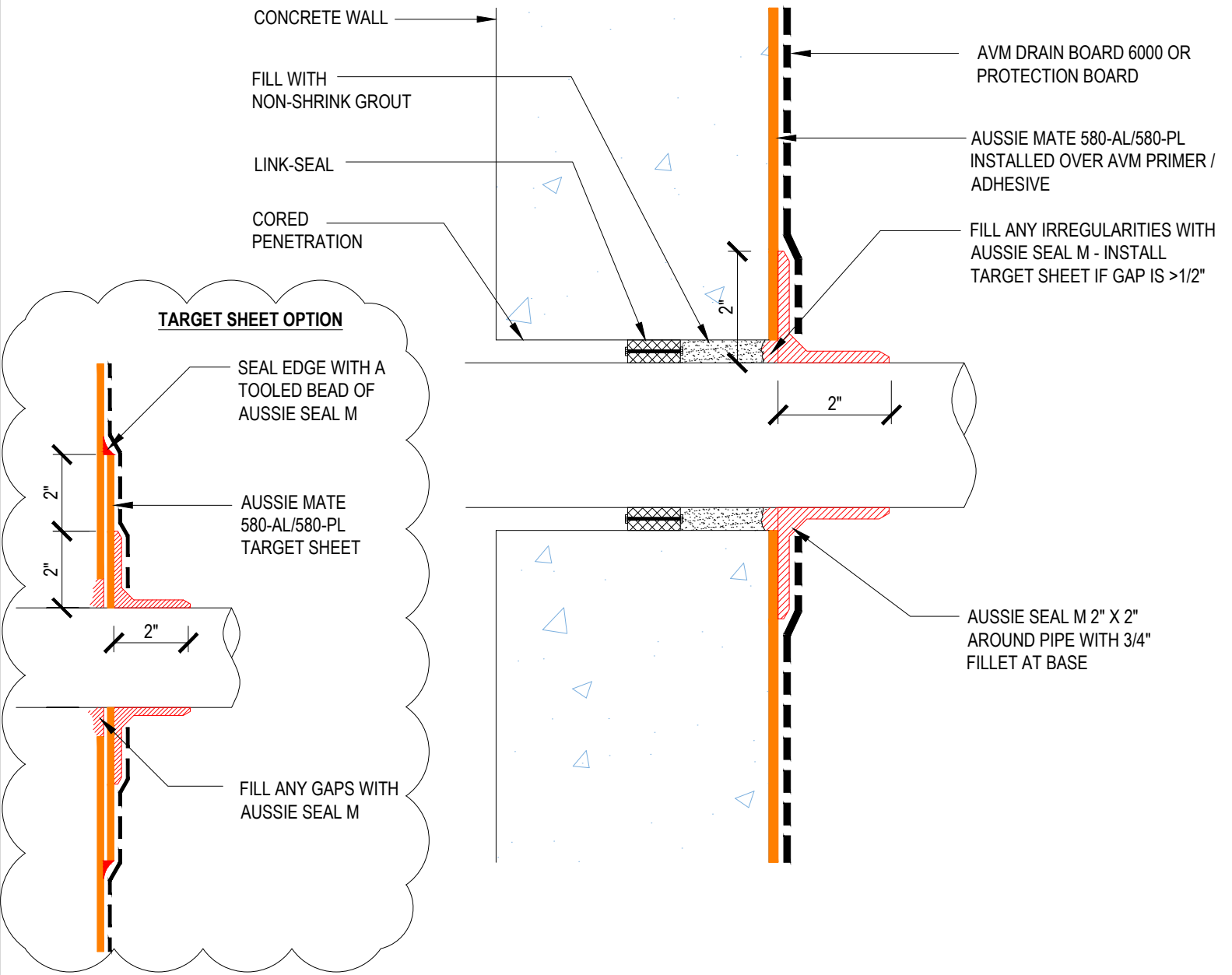

Notes:

1. Aussie Mate 580-AL is an LARR approved Waterproofing membrane and Methane Barrier.
2. Aussie Mate 580-AL is a heavy duty bituminous sheet membrane with aluminum protection layer for Below-Grade waterproofing applications that is available in a 60-mil or 80-mil thickness. Aussie Mate 580-AL may also be used as a methane and/or vapor barrier under horizontal slabs on grade.
3. Aussie Mate 580-PL is a 60-mil heavy duty bituminous sheet waterproofing membrane with a poly liner for below-grade waterproofing applications. Aussie Mate 580-PL cannot be used as a methane/vapor barrier in slab on grade applications.
4. **UV Exposure Limits:** Aussie Mate 580-AL - Up to 180 days. Aussie Mate 580-PL - Up to 30 days
5. See "Aussie Mate 580 Installation Instructions" for system requirements.

DETAIL #:
 0580-AL_580-PL-6505
 System:
 Aussie Mate 580-AL/580-PL

Sleeved Wall Penetration



AVM AUSSIE MATE 580-AL/580-PL

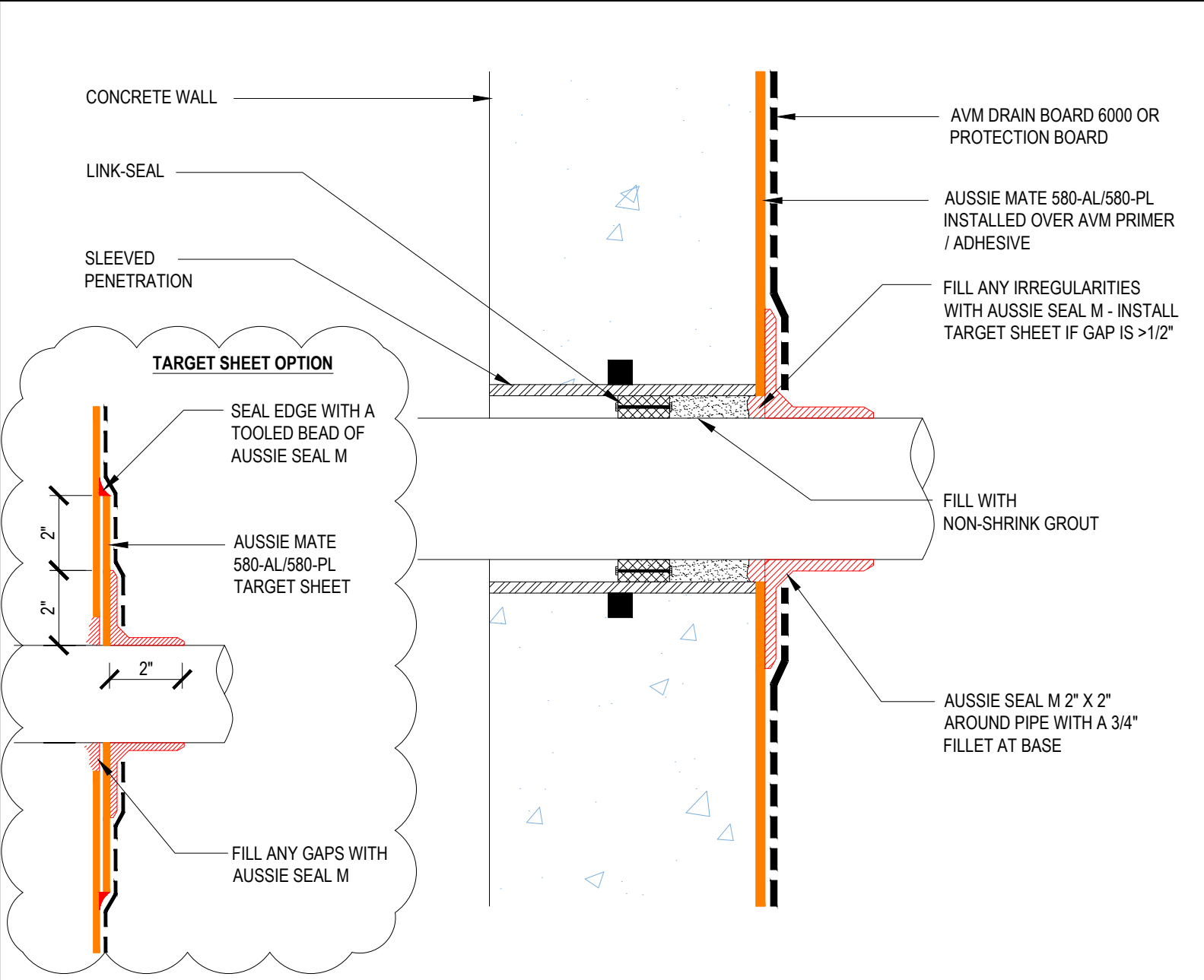

Notes:

1. Aussie Mate 580-AL is an LARR approved Waterproofing membrane and Methane Barrier.
2. Aussie Mate 580-AL is a heavy duty bituminous sheet membrane with aluminum protection layer for Below-Grade waterproofing applications that is available in a 60-mil or 80-mil thickness. Aussie Mate 580-AL may also be used as a methane and/or vapor barrier under horizontal slabs on grade.
3. Aussie Mate 580-PL is a 60-mil heavy duty bituminous sheet waterproofing membrane with a poly liner for below-grade waterproofing applications. Aussie Mate 580-PL cannot be used as a methane/vapor barrier in slab on grade applications.
4. **UV Exposure Limits:** Aussie Mate 580-AL - Up to 180 days. Aussie Mate 580-PL - Up to 30 days
5. See "Aussie Mate 580 Installation Instructions" for system requirements.

DETAIL #:
 0580-AL_580-PL-6506
 System:
 Aussie Mate 580-AL/580-PL

Penetration Target Sheet



AVM AUSSIE MATE 580-AL/580-PL

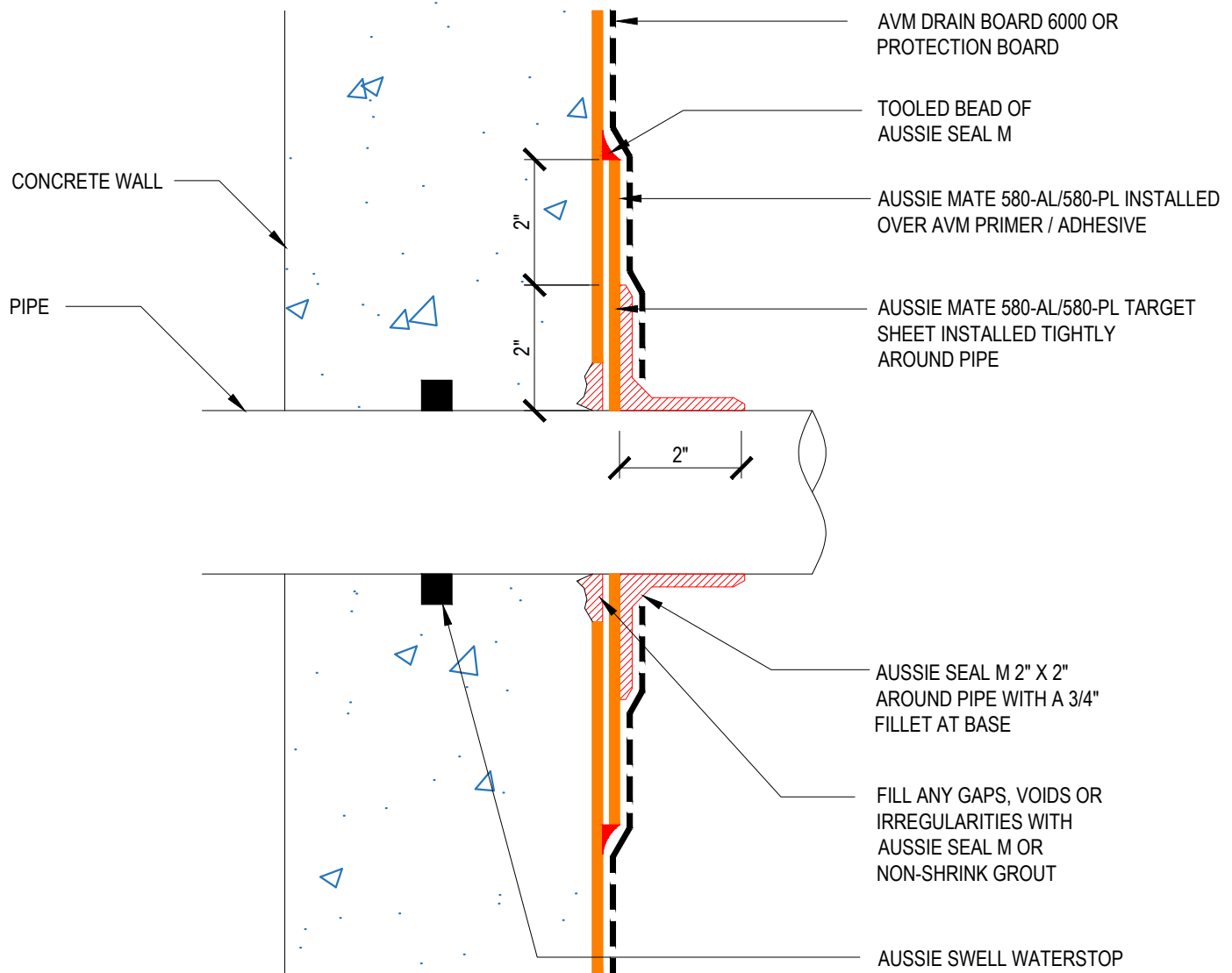

Notes:

1. Aussie Mate 580-AL is an LARR approved Waterproofing membrane and Methane Barrier.
2. Aussie Mate 580-AL is a heavy duty bituminous sheet membrane with aluminum protection layer for Below-Grade waterproofing applications that is available in a 60-mil or 80-mil thickness. Aussie Mate 580-AL may also be used as a methane and/or vapor barrier under horizontal slabs on grade.
3. Aussie Mate 580-PL is a 60-mil heavy duty bituminous sheet waterproofing membrane with a poly liner for below-grade waterproofing applications. Aussie Mate 580-PL cannot be used as a methane/vapor barrier in slab on grade applications.
4. **UV Exposure Limits:** Aussie Mate 580-AL - Up to 180 days. Aussie Mate 580-PL - Up to 30 days
5. See "Aussie Mate 580 Installation Instructions" for system requirements.

DETAIL #:
 0580-AL_580-PL-6510
 System:
 Aussie Mate 580-AL/580-PL

Multiple Pipe Penetration



AVM AUSSIE MATE 580-AL/580-PL

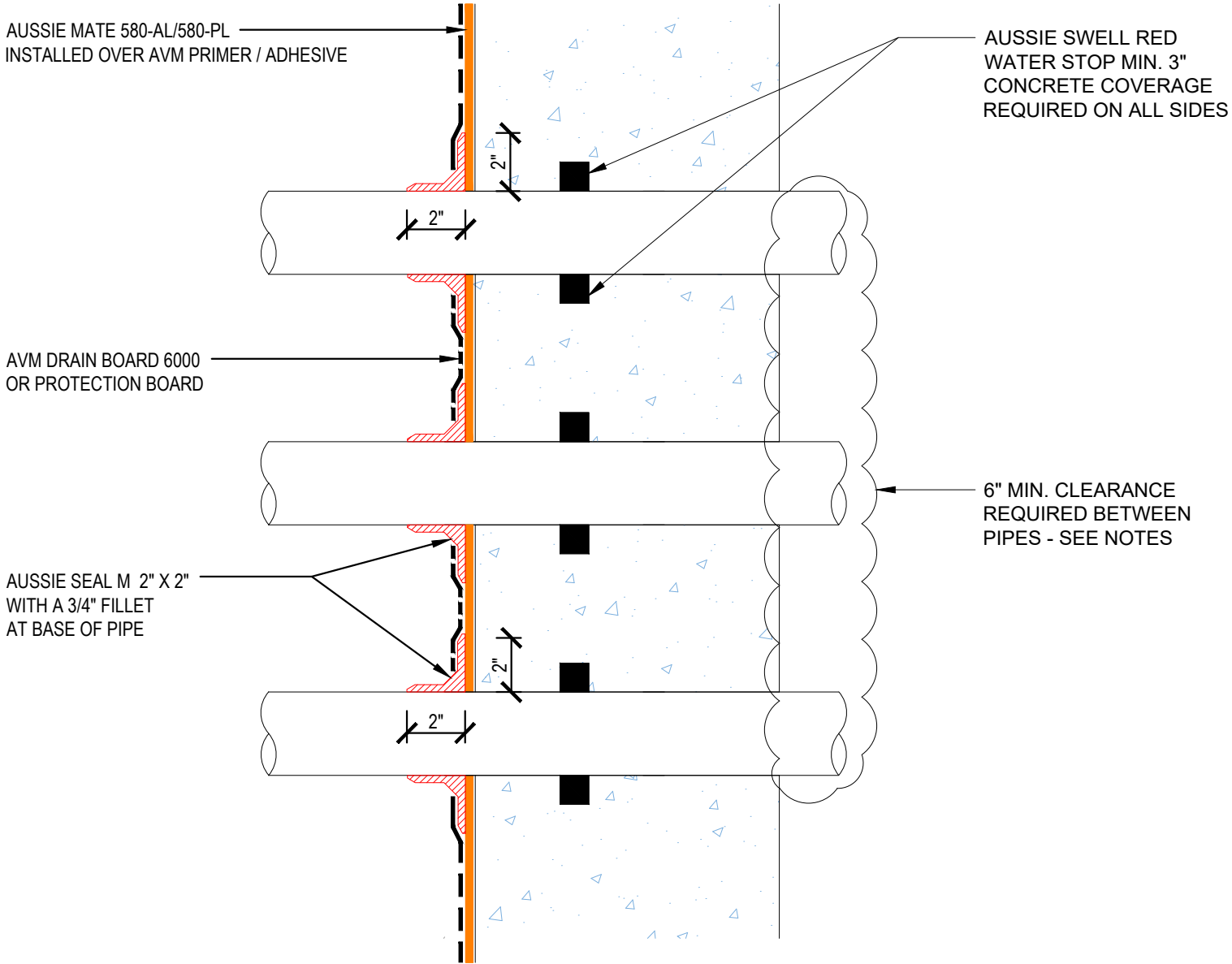

Notes:

1. Aussie Mate 580-AL is an LARR approved Waterproofing membrane and Methane Barrier.
2. Aussie Mate 580-AL is a heavy duty bituminous sheet membrane with aluminum protection layer for Below-Grade waterproofing applications that is available in a 60-mil or 80-mil thickness. Aussie Mate 580-AL may also be used as a methane and/or vapor barrier under horizontal slabs on grade.
3. Aussie Mate 580-PL is a 60-mil heavy duty bituminous sheet waterproofing membrane with a poly liner for below-grade waterproofing applications. Aussie Mate 580-PL cannot be used as a methane/vapor barrier in slab on grade applications.
4. **UV Exposure Limits:** Aussie Mate 580-AL - Up to 180 days. Aussie Mate 580-PL - Up to 30 days
5. See "Aussie Mate 580 Installation Instructions" for system requirements.

DETAIL #:
 0580-AL_580-PL-6512
 System:
 Aussie Mate 580-AL/580-PL

Deck Pipe Penetration



AVM AUSSIE MATE 580-AL/580-PL

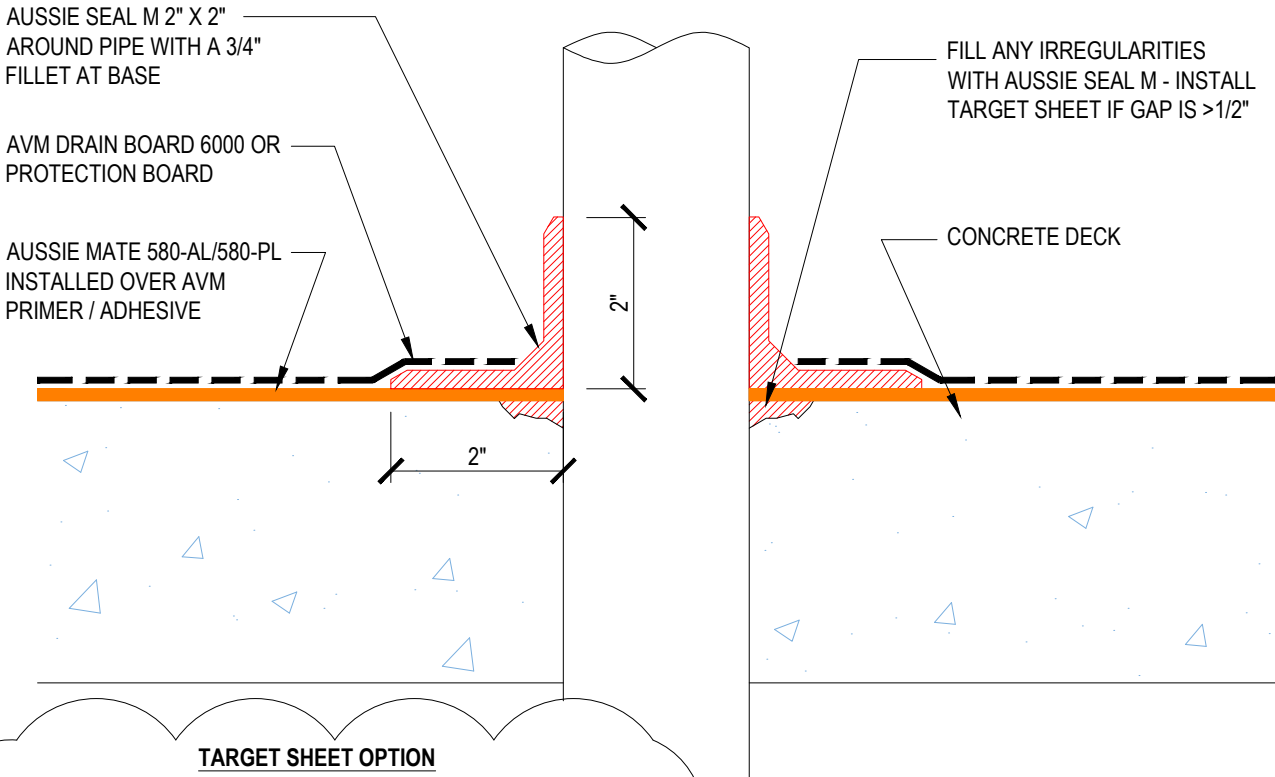

TARGET SHEET OPTION

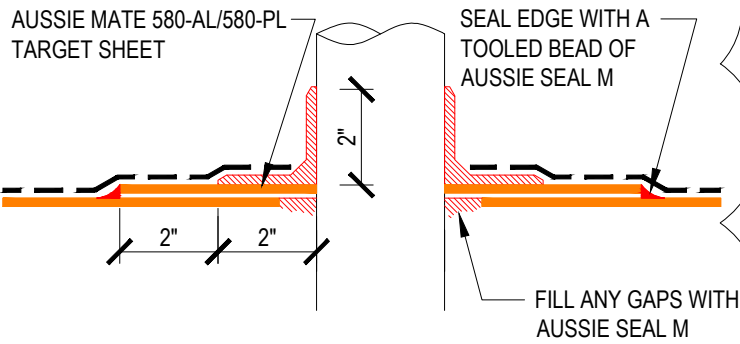

Notes:

1. Aussie Mate 580-AL is an LARR approved Waterproofing membrane and Methane Barrier.
2. Aussie Mate 580-AL is a heavy duty bituminous sheet membrane with aluminum protection layer for Below-Grade waterproofing applications that is available in a 60-mil or 80-mil thickness. Aussie Mate 580-AL may also be used as a methane and/or vapor barrier under horizontal slabs on grade.
3. Aussie Mate 580-PL is a 60-mil heavy duty bituminous sheet waterproofing membrane with a poly liner for below-grade waterproofing applications. Aussie Mate 580-PL cannot be used as a methane/vapor barrier in slab on grade applications.
4. **UV Exposure Limits:** Aussie Mate 580-AL - Up to 180 days. Aussie Mate 580-PL - Up to 30 days
5. See "Aussie Mate 580 Installation Instructions" for system requirements.

DETAIL #:
0580-AL_580-PL-7004

System:

Aussie Mate 580-AL/580-PL

Standard Overlap



AVM AUSSIE MATE 580-AL/580-PL

FACTORY LAP

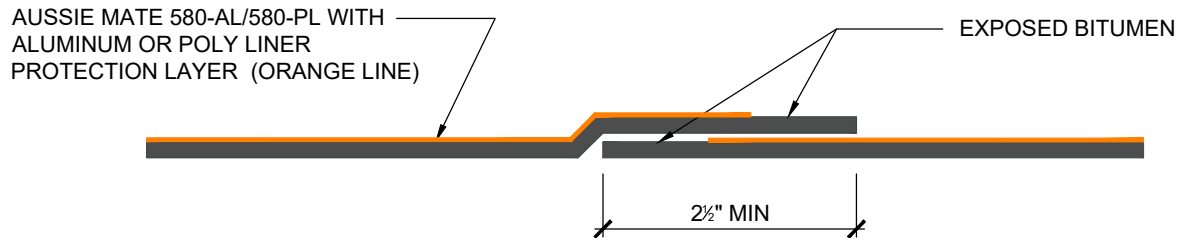

Important Note: When installing the "Factory Lap", The Installation procedure should be as follows:

1. Before bonding the next layer of Aussie Mate to an existing layer, Remove both clear plastic films from the factory laps (Where the protection layer ends)
2. Make sure surfaces are clean before bonding overlaps.
3. Install the next sheet of Aussie Mate with a minimum 2-1/2" overlap.
4. Roll the steel roller over the lap several times while applying pressure to ensure proper adhesion.
5. In cold weather, using heat gun will improve adhesion.

NON-FACTORY LAP

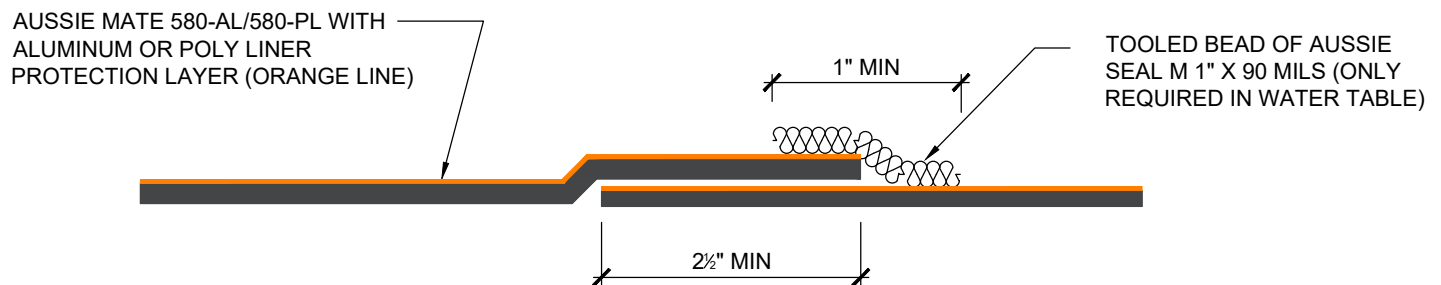

Important Note: When installing the "Non-Factory Lap", The Installation procedure should be as follows:

1. Make sure surfaces are clean before bonding overlaps.
2. Install the next sheet of Aussie Mate with a minimum 2-1/2" overlap.
3. Roll the steel roller over the lap several times while applying pressure to ensure proper adhesion.
4. In cold weather, using heat gun will improve adhesion.
5. In the water-table, on non-factory laps Apply Sealant (Aussie Seal M) over the seam.

Notes:

1. Aussie Mate 580-AL is an LARR approved Waterproofing membrane and Methane Barrier.
2. Aussie Mate 580-AL is a heavy duty bituminous sheet membrane with aluminum protection layer for Below-Grade waterproofing applications that is available in a 60-mil or 80-mil thickness. Aussie Mate 580-AL may also be used as a methane and/or vapor barrier under horizontal slabs on grade.
3. Aussie Mate 580-PL is a 60-mil heavy duty bituminous sheet waterproofing membrane with a poly liner for below-grade waterproofing applications. Aussie Mate 580-PL cannot be used as a methane/vapor barrier in slab on grade applications.
4. **UV Exposure Limits:** Aussie Mate 580-AL - Up to 180 days. Aussie Mate 580-PL - Up to 30 days
5. See "Aussie Mate 580 Installation Instructions" for system requirements.

DETAIL #:
0580-AL_580-PL-7006
 System:
Aussie Mate 580-AL/580-PL

Outside Corner



AVM AUSSIE MATE 580-AL/580-PL

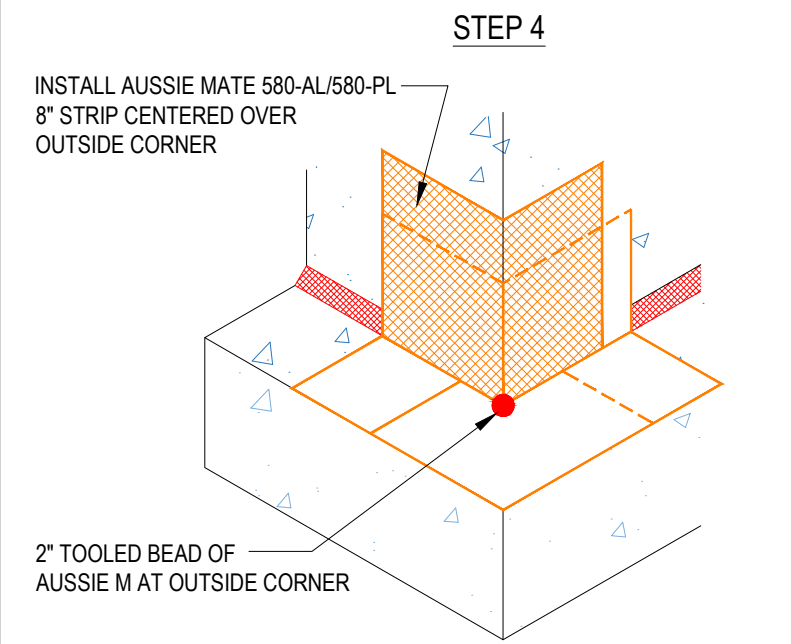
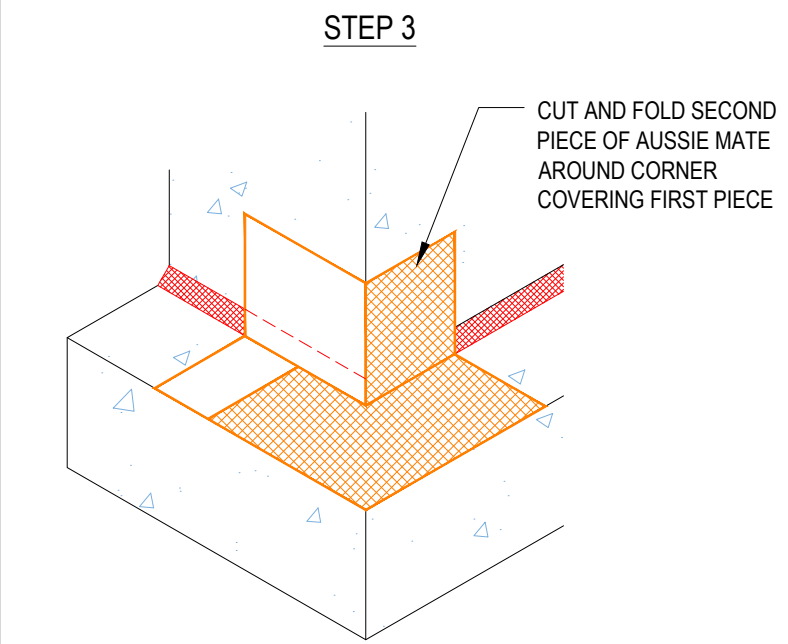
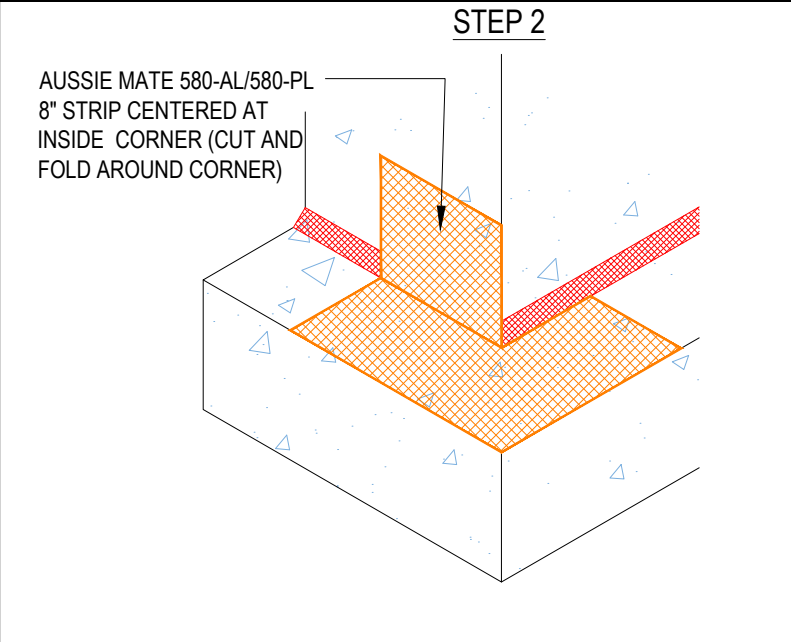
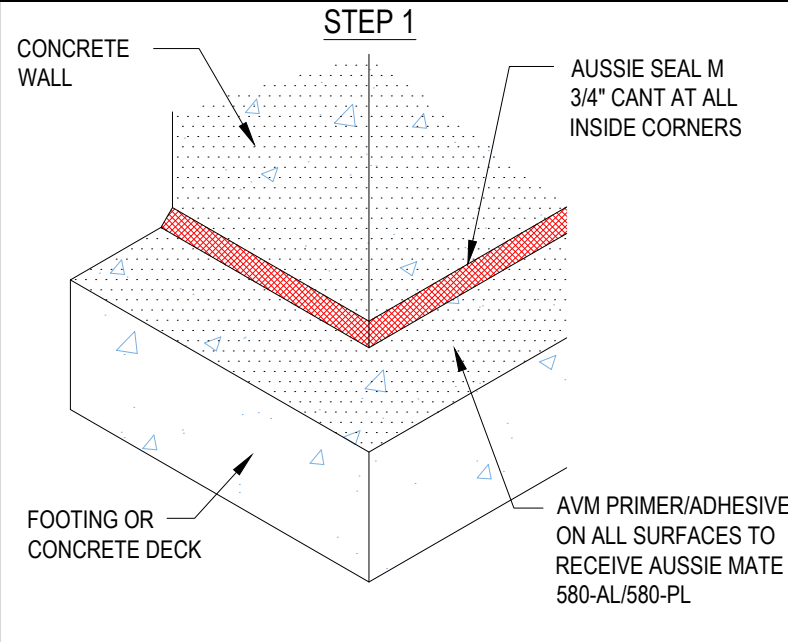

Notes:

1. Aussie Mate 580-AL is an LARR approved Waterproofing membrane and Methane Barrier.
2. Aussie Mate 580-AL is a heavy duty bituminous sheet membrane with aluminum protection layer for Below-Grade waterproofing applications that is available in a 60-mil or 80-mil thickness. Aussie Mate 580-AL may also be used as a methane and/or vapor barrier under horizontal slabs on grade.
3. Aussie Mate 580-PL is a 60-mil heavy duty bituminous sheet waterproofing membrane with a poly liner for below-grade waterproofing applications. Aussie Mate 580-PL cannot be used as a methane/vapor barrier in slab on grade applications.
4. **UV Exposure Limits:** Aussie Mate 580-AL - Up to 180 days. Aussie Mate 580-PL - Up to 30 days
5. See "Aussie Mate 580 Installation Instructions" for system requirements.

DETAIL #:
0580-AL_580-PL-7008
 System:
Aussie Mate 580-AL/580-PL

Inside Corner



AVM AUSSIE MATE 580-AL/580-PL

STEP 1

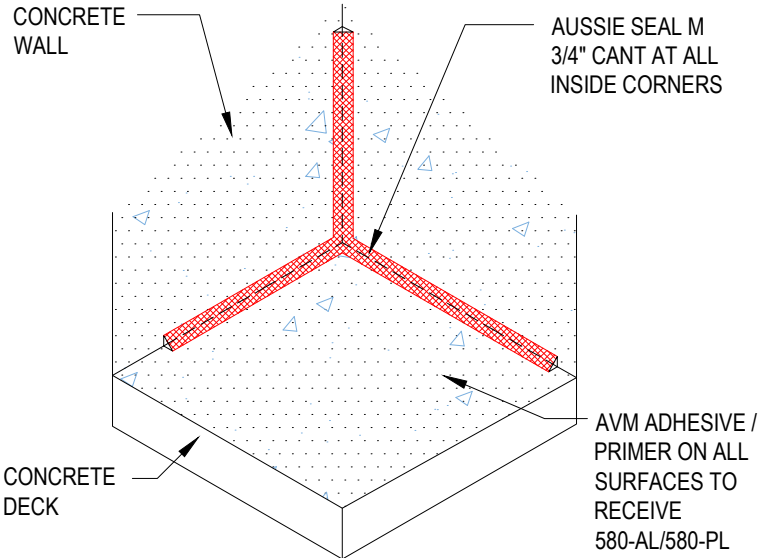

STEP 2

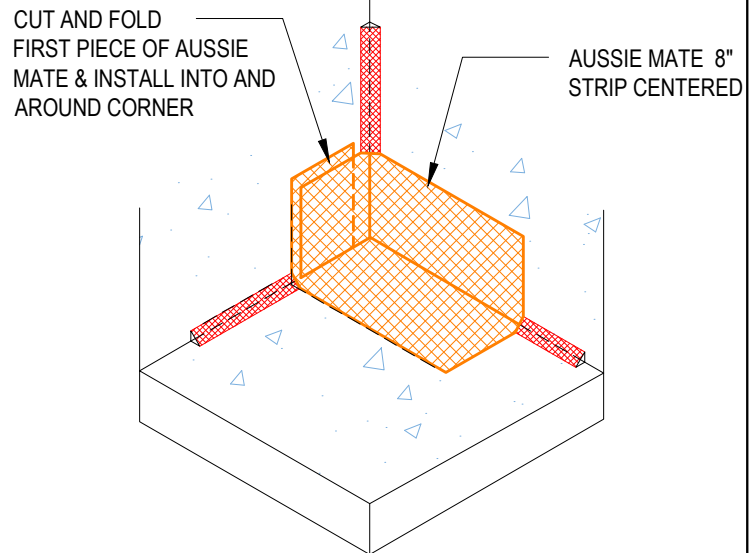

STEP 3

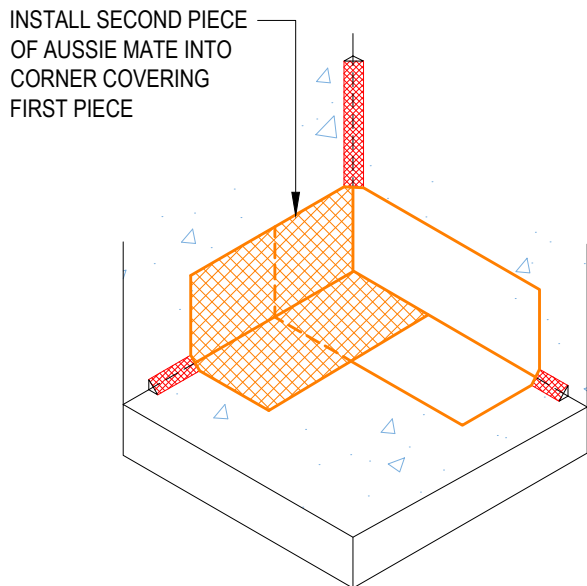

STEP 4

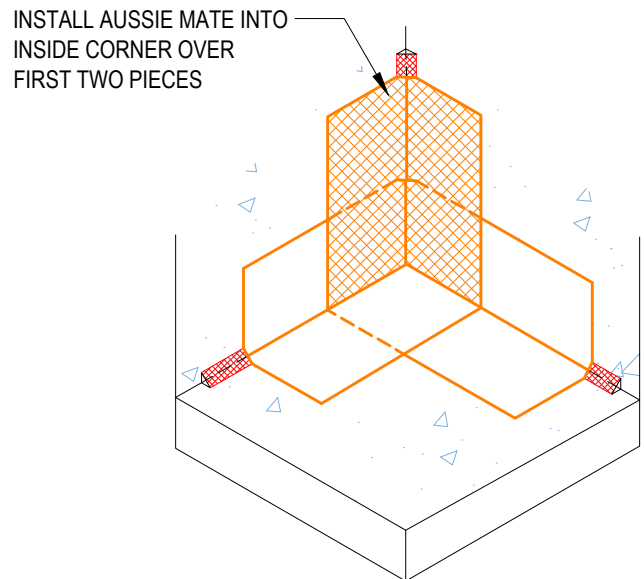

Notes:

1. Aussie Mate 580-AL is an LARR approved Waterproofing membrane and Methane Barrier.
2. Aussie Mate 580-AL is a heavy duty bituminous sheet membrane with aluminum protection layer for Below-Grade waterproofing applications that is available in a 60-mil or 80-mil thickness. Aussie Mate 580-AL may also be used as a methane and/or vapor barrier under horizontal slabs on grade.
3. Aussie Mate 580-PL is a 60-mil heavy duty bituminous sheet waterproofing membrane with a poly liner for below-grade waterproofing applications. Aussie Mate 580-PL cannot be used as a methane/vapor barrier in slab on grade applications.
4. **UV Exposure Limits:** Aussie Mate 580-AL - Up to 180 days. Aussie Mate 580-PL - Up to 30 days
5. See "Aussie Mate 580 Installation Instructions" for system requirements.