



INSTALLATION AVM SYSTEM 100 ELASTO FIBERDECK

AVM System 100 Elasto Fiberdeck Installation Instructions

DESCRIPTION

AVM Elasto Fiberdeck 100 is a traffic bearing, roof and walking deck waterproofing system. The **Elasto Fiberdeck 100 System** has a Class A Roofing Classification and a 1-hour fire rating (when installed per ICC ESR-2125). The **Elasto Fiberdeck 100 System** can be applied directly to new or existing concrete, plywood decks, and sheet metal flashing providing exceptional protection against the elements and heavy pedestrian traffic. Please refer the AVM website for latest ICC Reports.

APPLICATIONS

The **Elasto Fiberdeck 100** is suitable for both residential and commercial structures and is commonly installed on sun decks, balconies, walkways, stairs, courtyards and many other areas.

Technical Data - AVM System 100	
Fire Rating	Class A, 1 Hour
Weatherometer	No Cracking, Softening, Cracking
Wind Uplift (Tested/Approved)	135+ lbs./sq. ft., -227 MPH/90 MPH
Abrasion	4.58% (Pass)
Bond Strength (Once Cured)	134 PSI
Compressive Strength ASTM C39,C172,C192,C470 @ 28 Days	Crete 6400: 3700 PSI / Crete 6400-SC 2500 PSI
Impact Resistance, ASTM D-3746	No Cracking or Splits

General Data - AVM System 100	
Shelf Life: (Liquids)	One year in original unopened packaging.
Storage Conditions	Store dry at 50°-90°F. If frozen, discard
Crete 6400 Mixing	Pre-proportioned kit. 1-bag to 1-gal. additive
Crete 6400-SC Mixing	1-bag with 1 gal water
Crete 6400 Color	Gray
Base/Texture Colors	STD: Silver. Many custom colors available.
Top Coat Colors	Clear Sealer or See AVM's Color Chart Custom colors are available - Call for details.

Minimum Dry Thickness - Complete System: 0.310. (AVM Crete 6400/6400-SC must be at least 0.250" thick when dry)

DELIVERY, STORAGE, & HANDLING

Delivery of all the **Elasto Fiberdeck 100** system materials to the job site must be in their original sealed containers and bags, with the manufacturer's name and label still intact. Handle and store containers and bags in accordance with the printed instructions on labels and product SDSs. Store the system components at temperatures between 50° and 90°. Do not store materials in direct sunlight or where they may be damaged by water or rain. It is important to keep materials dry. Keep all materials out of the reach of children. If irritation occurs during use, liberally flush affected areas with water. If irritation continues, see a physician immediately.

SYSTEM COMPONENTS/ACCESSORY PRODUCTS

AVM Crete 6400: A polymer modified cement mix designed for thin sloping, leveling and patching applications ranging from 0-4" in thickness. It comes in a pre-portioned kit consisting of Aggregate 400 mixed with Additive 7400 or Aggregate 400-SC mixed with water.

Aggregate 400: 50-pound bag of Aggregate 400, a high-performance concrete mix.

Aggregate 400-SC: 50-pound bag of Aggregate 400, a high-performance concrete mix with dry polymer.

AVM Additive 7400: a ready to use high-performance acrylic based concrete additive admixture for concrete mix.

Metal Lath 2.5#: a roll of electro-galvanized metal lath at 2.5lbs per sq/yard.

AVM Primer 100: a high-performance water-based acrylic primer used in multiple AVM waterproofing systems including the System 100 Elasto Fiberdeck System.

Mat 100: a fiberglass reinforcing mat used in the AVM System 100 Elasto Fiberdeck System.

Mat 800: a polyester reinforcing mat used in the AVM System 100 Elasto Fiberdeck System.

AVM Base Resin 100: a high-performance water-based acrylic resin used for laminating the Fiberglass Mat 100 or the polyester Mat 800 which creates the waterproofing membrane layer in multiple waterproofing systems including the AVM System 100 Elasto Fiberdeck System.

AVM Texture 100: a high-performance acrylic-based texture used in the AVM System 100 Elasto Fiberdeck System.

AVM TX-100: a high-performance cement-based texture used in the AVM System 100 Elasto Fiberdeck System.

Topcoat Sealer 4100: an acrylic, water based sealer, chemically modified to promote deep penetration and provide long lasting protection to the coated surfaces.

Topcoat Sealer 4150: a heavy-duty high-performance water based acrylic sealer designed to promote deep penetration and provide long lasting protection to the coated surfaces.

Acricpatch 5020: a high-performance semi-rigid acrylic patch used in surface preparation for filling in joints, cracks, & wood knots not exceeding ¼" maximum thickness as needed.

Aussie Seal M: a marine grade single component polyether used for sealing perimeter joints and other waterproofing system discontinuities.

LIMITATIONS

AVM System 100 Elasto Fiberdeck and its system components should not be installed at temperatures below 50° or at temperatures above 90°. Do not install system or its components in the rain or if precipitation is imminent.

Warn personnel against hazards of materials to the skin and eyes. The fiberglass mat can be an irritant to bare skin and the resins can cause injury to the eye if splashed into them. See component's SDS for complete safety information.

When installing the AVM System 100 Elasto Fiberdeck, refer to the Safety Data Sheet and follow local safety requirements in regards to PPE.

Protect adjacent surfaces which could be damaged during the application procedure.

The deck substrate shall be properly sloped to freely drain and eliminate the ponding of water.

SUBSTRATE

Plywood Substrate:

Plywood must be at least 5/8" inch thick, Exterior Grade, Structural plywood (no OSB) with maximum span of 16" between supports. All plywood edges must be properly supported and fastened to the support structure below. Joints must be properly blocked. All nails or screws shall be flush or countersunk to the plywood surface. Plywood must have 1/8" inch spacing between sheets, installed perpendicular to the supports below and installed per code. It is optional to seal plywood joints and cracks flush with the AVM Acripatch 5020 patching compound.

Plywood substrate shall be clean, free of dirt, dust, oil, grease, and other materials that can prevent or reduce the bonding of the system to the plywood. Thoroughly clean the areas to receive the System 100 Elasto Fiberdeck with a blower to remove all dust and debris.

Plywood should be securely attached with glue to wood beams and joists and screwed into the plywood using non-rising, ring shank nails or screws spaced at 6 inches on centers maximum. Screws must be counter sunk. If secured differently, please contact AVM.

Damaged plywood substrate areas with noted defects or deflections shall be repaired or replaced prior to commencement of deck system application. Ensure that substrate provides adequate slope for proper drainage. (Minimum slope required is 1/4" per foot).

Ensure that all sheet metal flashing and related accessories are properly secured and joints solidly imbedded in sealant. Install Galvanized or preferably Bonderized edging metal where shown or required for a complete installation. Apply Aussie Seal M to all exposed sheet metal joints, and other hard to reach areas, especially areas prone to leaking. Special attention should be given to the following areas: Corners, around drains and scuppers, voids, holes, and around posts. Sheet metal should be installed per local requirements.

Clean (scrape if necessary) all sheet metal areas to receive the deck coating. Sheet metals made of Galvanized or Bonderized Steel need to be wiped clean using a rag and water mixed with a strong detergent to ensure all residues are removed. Stainless Steel and Copper flashings should be lightly sanded to improve adhesion.

It is recommended to install the deck-to-wall sheet metals (L-Metals, Zee Bars, etc.) over the AVM Crete, if possible. If the metals are already in place, install AVM Crete over them.

Wood framing and structure must meet local building codes and should not have excessive deflection, which can cause the deck coating system to crack

Concrete Substrate:

Remove any laitance, oil, grease, curing agents, debris and other deleterious materials from surfaces scheduled to receive application. High pressure washing is recommended. Just prior to beginning the installation of the deck system, thoroughly clean the areas with a blower to remove all construction/environmental debris and dust from the work area.

Concrete should have a minimum 28-day cure time with a minimum compression strength of 2000 psi. Concrete finish should be straight without waviness/undulations or noted defects with a troweled and finished light broom surface texture. Damaged concrete surfaces with noted defects shall be repaired prior to commencement of the deck system application. Verify that concrete slab or topping provides adequate slope for proper drainage (Minimum slope 1/4" per foot). AVM Crete 6400 can be used to aid in sloping and to repair defects in uneven concrete.

All cracks up to 1/8" must be filled flush with Acripatch and reinforced with 6" polyester mat 800. Cracks that exceed 1/8" should be reviewed prior to coating by AVM Representative

Verify that all sheet metal flashing and related accessories are properly secured and joints solidly imbedded in sealant. Install edging metal per details.

If expansion joints exist, contact AVM Industries for further instructions on how they should be handled. You may also refer to supplied details for suggested waterproofing methods of the expansion joints.

INSTALLATION

Once the substrate is prepped and inspected per the instructions above, the System 100 Elasto Fiberdeck system can be installed. Steps will differ depending on if the System 100 Elasto Fiberdeck is installed over concrete surfaces or plywood surfaces.

Concrete Surfaces

Concrete substrates must be 2" thick and a minimum of 2000 psi. Finished concrete surfaces can be primed with the optional AVM Primer 100. The primer is used to assist in the adhesion of the system to the prepared surface. Apply AVM Primer 100 to all the surfaces scheduled to receive application. Apply at the rate of approximately one (1) gallon per 200 square feet. Allow primer to cure to complete dryness (approximately 15-45 minutes depending on temperature and wind conditions) before base membrane is applied. Cover all primers within 24 hours of initial application or re-priming shall be required.

Once the AVM Primer 100 has been installed, AVM Mat 100 (or Mat 800) is installed over the surface. Lay out the AVM Mat 100 (or Mat 800) in shingle fashion, with the top layer at the higher level overlapping the lower level a minimum of 2 inches. Please use the below instructions when installing the reinforcing fabric over the following:

Edge Metal: Terminate the mat approximately ½ inch from the edge metal's edge. (Minimum 1 inch overlap required)

Stucco Stops/Screeds: Roll up the mat until it reaches the stucco stop or a minimum 1 inch high.

Drains: Mat layout depends on the type of drain. Make sure that the water will flow over the mat and into the drain. Do not allow the water to go anywhere but into the drain. Refer to drain manufacture's details as well.

1. Before applying the AVM Base Resin 100, cut out all bubbles and replace the damaged mat as required.
2. For more pleasing aesthetics, feather out mat joints and check corners and edges for gaps, twists, or other damage.
3. Repair or replace the mat as required.

Apply the AVM Base Resin 100 over the AVM Mat 100/800 at the rate of 40-50 square feet per gallon to fully encapsulate the mat. Work the AVM Base Resin 100 into the reinforcing mat using a roller and a brush. Apply sufficient pressure to the roller to thoroughly embed the AVM Base Resin 100 into the mat. Allow the base coat membrane to cure at least overnight. Prior to resuming work, verify that the base coat membrane is thoroughly dry.

Once the base coat has cured, it is important to inspect the system surface for bubbles at the mat's joints and the field area and for pinholes in the base coat membrane's surface.

If bubbles are found, remove the bubbles and surrounding area by cutting them out and reinstalling the base coat membrane per the base coat membrane installation instructions. Remove blotches, clumps and other imperfections using a scraper or a knife. If necessary, re-install a small piece of the base coat membrane per the base coat membrane installation instructions.

Carefully inspect the membrane for pinholes. (The mat should be completely saturated) If not fully saturated, or pinholes are found, apply a second coat of the AVM Base Resin 100 at the rate of one (1) gallon per 100-150 square feet, or until the pinholes are sealed.

Thoroughly clean the base coat membrane by broom or (preferably) by blower. If you wish, you may apply a thin coat of the AVM Acripatch 5020 at the mat's seams and in other areas where imperfections still exist (This helps to make the deck coating look more uniform once completed).

Installation Instructions

Once the base coat has been inspected and repaired as needed, the Texture 100 or the TX-100 is installed. Texture 100 is acrylic based and the TX-100 is concrete based and they are interchangeable. Texture 100: Thoroughly mix the bucket's contents with a drill and paddle before use. TX-100: Mix 1 bag of TX-100 with approximately 1.5 gallons of Additive 7400. Surface Prep: Thoroughly clean the base coat membrane by broom or (preferably) by blower. Spray, trowel, roll or use a commercial grade soft sponge to apply the AVM Texture at the rate of one (1) gallon per 40-60 square feet. Membrane should be completely covered in texture. If spraying, adjust the spray nozzle to apply the material to match the approved sample. Optional troweled, knock down, design, and other finishes may be applied. Allow the texture coat to properly cure prior to walking on the textured areas. After curing, remove all masking materials. Then lightly scrape the texture coat with a scraper and remove all the residue (preferably by blower) prior to beginning the application of the AVM Topcoat Sealer. A second coat of the AVM Texture may be applied to achieve a denser coverage.

Finally, the Topcoat Sealer, 4100/4150 Acrylic Topcoat Sealer, is installed once the deck areas have been thoroughly cleaned. Apply the AVM Topcoat Sealer over the cured texture coat at the rate of 100-120 square feet per gallon. Allow the AVM Topcoat Sealer to cure for several hours. (Preferably 24 hours) If you cannot wait 24 hours, light foot traffic may be allowed when the AVM Topcoat Sealer is no longer tacky.

The standard installation of the System 100 Elasto Fiberdeck over concrete surfaces can be seen in the assembly table below:

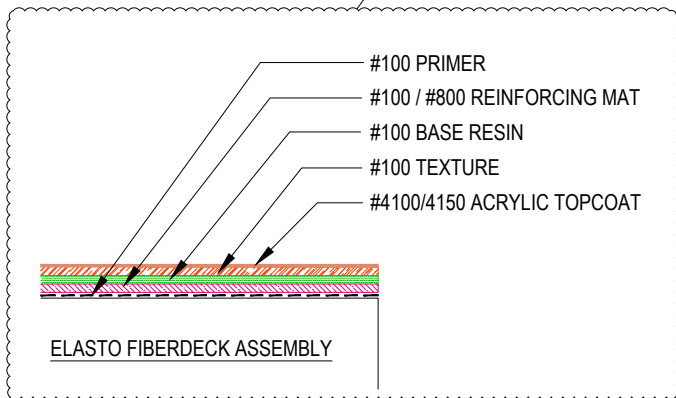

When turning up a wall, a minimum 26-gauge metal flashing would be installed at the corner, with a preferred 3-4" (2" minimum) onto the deck and a minimum of 6" up the vertical. The weep screed would be installed where it angles a minimum of 3" up the wall. The System 100 Elasto Fiberdeck should terminate below the weep screed, while the sheet metal should extend above the top of the weep screed. The below diagrams will show this in a section view and isometric view.

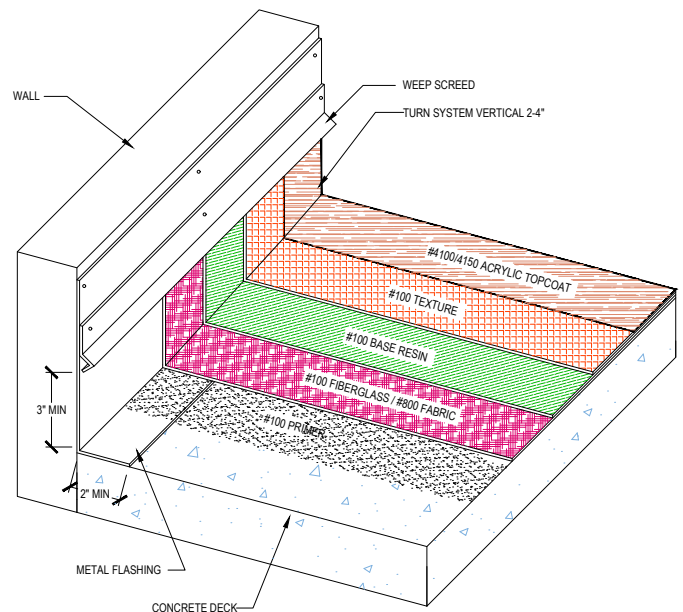
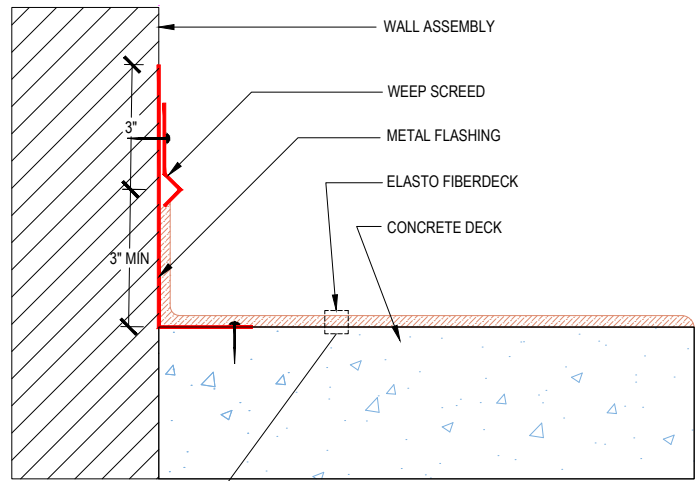

Installation Instructions

When terminating the system at a threshold, first extend the metal flashing 2" minimum (3-4" preferred) onto the horizontal concrete deck. The metal flashing will turn up the threshold and then come over it. The full System 100 Elasto Fiberdeck assembly would come up the vertical of the metal flashing and terminate. Extend the reinforcing fabric and the base coat resin to the back of the sheet metal flashing that extends onto the threshold. Use AVM Aussie Seal M beads to adhere the Door Sill Pan over the threshold. This is shown in the diagram below.

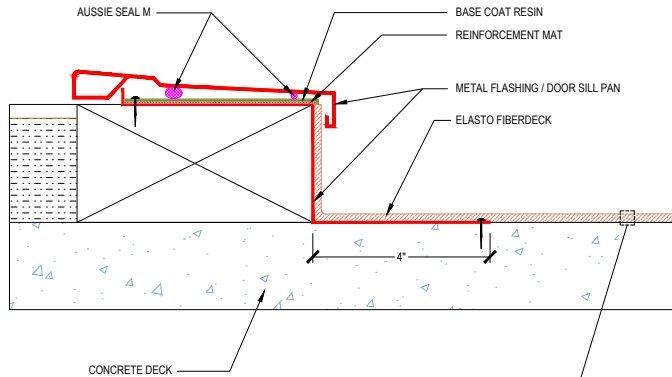

When installing the System 100 Elasto Fiberdeck at a drain assembly, inspect the drain to ensure the substrate is ready for membrane installation. Remove all paints, primer, oils, or any foreign material by abrading/sanding the drain to bare metal prior to full system application. Drains should have a minimum of 2" flange for the system to come onto and should also sit low enough for sufficient slope. Weep holes should not be blocked. The below diagram will show the installation at a drain assembly.

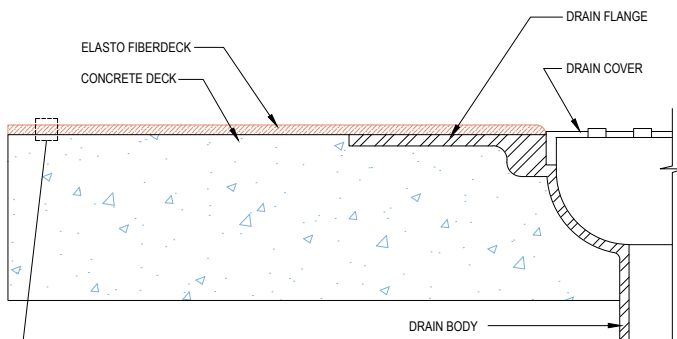

When coming over a concrete curb, install a minimum 2" X 2" sheet metal flashing in the corner you intend to bring the System 100 assembly over. Bring the assembly over the sheet metal flashing and turn up vertically onto the concrete curb. The curb should be a minimum of 8" high. Bring the System 100 assembly over the top of the curb and terminate onto a two-piece counter flashing that sits over the roofing system. See below diagram.

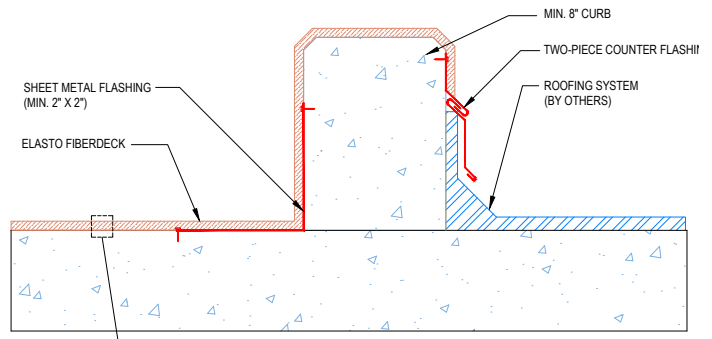

Plywood Surfaces

When installing the System 100 Elasto Fiberdeck over plywood, plywood must be a minimum of 5/8" thick. Follow the instructions for substrate preparation above for prepared plywood. AVM Crete 6400 needs to be installed over the plywood prior to the system application.

Prior to installing any components of the AVM Crete 6400, the AVM Primer 100 (optional) can be applied to the plywood substrate. Apply at the rate of approximately one (1) gallon per 200-300 square feet. Allow primer to cure until dry to the touch. (approximately 15-45 minutes depending on temperature and wind conditions) If over 24 hours have passed since the initial primer application, re priming shall be required.

Metal Lath at 2.5 lbs is then installed over the primer. Lay out the Metal Lath 2.5lb per square yard on the entire plywood area to receive the AVM Crete. Terminate the AVM metal lath 2.5# 1/4 inch away from any walls or posts and 2" away from the deck's edges. Fasten the AVM Metal Lath 2.5# sheets by stapling them to the deck using 16 gauge Galvanized staples (or other non-rusting type) with 1 inch crown and 5/8" inch long legs at the rate of a minimum of 16 staples per square foot. For seams, follow the below methods:

Side by Side method: Lay the sheets of the Metal Lath 2.5# as close as possible to each other without overlapping them. (Maximum distance between sheets should not exceed ¼ inch). Staple the sheets together at the rate of one staple every 3 inches (three inch on center), and by shooting one leg of the staple into one sheet and the other staple leg into the other sheet, tying them together.

Overlapping Method: Overlap the sheets of the Metal Lath 2.5# a minimum of ¾" Staple the sheets together at the rate of one staple every 3 inches (three inch on center), and by shooting one leg of the staple into one sheet and the other staple leg into the other sheet, tying them together.

The layout of the Metal Lath 2.5# depends on the type of drain. Make sure that the water will flow over the concrete and into the drain. Do not allow the water to go anywhere but into the drain, scuppers, or edge of the deck per the deck's design.

Once the Metal Lath 2.5# is placed, AVM Crete 6400 can then be placed onto the surface. To make AVM Crete 6400, mix one bag of the AVM Aggregate 400 with one gallon of the AVM Concrete Additive 7400 using an electric drill and paddle. Mix well to ensure a good consistency. Apply the AVM Crete by using a trowel or float. The AVM Crete may be worked down to a minimum total dry thickness of ¼ inch. To prevent/reduce cracking, it's highly recommended that the Crete 6400 layer be installed a minimum ½" thick. Do not apply more than 1.0" in thickness. If more than 1.0" in thickness of the AVM Crete 6400 is required, add ½ gallon (approximately 7 pounds) of dry ¼" Pea Gravel to each mix of 1 gallon of AVM Concrete Additive 7400 and one bag of AVM Aggregate 400.

For AVM Crete ½ inch thick or less allow 24-48 hours curing time. For AVM Crete over ½ inch thick allow a minimum of 72 hours curing time. (The curing times are based on nice sunny days reaching 75°F and no more than 50% relative humidity. Actual curing times may vary based on weather conditions) Do not proceed to the next step if the AVM Crete is not sufficiently cured.

Once the AVM Crete 6400 has cured, the rest of the system would be installed. AVM Mat 100 (or Mat 800) is installed over the AVM Crete 6400. Lay out the AVM Mat 100 (or Mat 800) in shingle fashion, with the top layer at the higher level overlapping the lower level a minimum of 2 inches. Please use the below instructions when installing the reinforcing fabric over the following:

Edge Metal: Terminate the mat approximately ½ inch from the edge metal's edge. (Minimum 1inch overlap required)

Stucco Stops/Screeds: Roll up the mat until it reaches the stucco stop or a minimum 1 inch high.

Drains: Mat layout depends on the type of drain. Make sure that the water will flow over the mat and into the drain. Do not allow the water to go anywhere but into the drain. Refer to drain manufacturer's details as well.

1. Before applying the AVM Base Resin 100, cut out all bubbles and replace damaged mat as required.
2. For more pleasing aesthetics, feather out mat joints and check corners and edges for gaps, twists, or other damage.
3. Repair or replace the mat as required.

Apply the AVM Base Resin 100 over the AVM Mat 100/800 at the rate of 40-50 square feet per gallon to fully encapsulate the mat. Work the AVM Base Resin 100 into the reinforcing mat using a roller and a brush. Apply sufficient pressure to the roller to thoroughly embed the AVM Base Resin 100 into the mat. Allow the base coat membrane to cure at least overnight. Prior to resuming work, verify that the base coat membrane is thoroughly dry.

Once the base coat has cured, it is important to inspect the system surface for bubbles at the mat's joints and the field area and for pinholes in the base coat membrane's surface.

If bubbles are found, remove the bubbles and surrounding area by cutting them out and reinstalling the base coat membrane per the base coat membrane installation instructions. Remove blotches, clumps and other imperfections using a scraper or a knife. If necessary, re-install a small piece of the base coat membrane per the base coat membrane installation instructions.

Carefully inspect the membrane for pinholes. (The mat should be completely saturated) If not fully saturated, or pinholes are found, apply a second coat of the AVM Base Resin 100 at the rate of one (1) gallon per 100-150 square feet, or until the pinholes are sealed.

Thoroughly clean the base coat membrane by broom or (preferably) by blower. If you wish, you may apply a thin coat of the AVM Acripatch 5020 at the mat's seams and in other areas where imperfections still exist (This helps to make the deck coating look more uniform once completed).

Installation Instructions

Once the base coat has been inspected and repaired as needed, the Texture 100 or the TX-100 is installed. Texture 100 is acrylic based and the TX-100 is concrete based and they are interchangeable. Texture 100: Thoroughly mix the bucket's contents with a drill and paddle before use. TX-100: Mix 1 bag of TX-100 with approximately 1.5 gallons of Additive 7400. Surface Prep: Thoroughly clean the base coat membrane by broom or (preferably) by blower. Spray, trowel, roll or use a commercial grade soft sponge to apply the AVM Texture at the rate of one (1) gallon per 40-60 square feet. Membrane should be completely covered in texture (See coverage chart for different types of textures). If spraying, adjust the spray nozzle to apply the material to match the approved sample. Optional troweled, knock down, design, and other finishes may be applied. Allow the texture coat to properly cure prior to walking on the textured areas. After curing, remove all masking materials. Then lightly scrape the texture coat with a scraper and remove all the residue (preferably by blower) prior to beginning the application of the AVM Topcoat Sealer. A second coat of the AVM Texture may be applied to achieve a denser coverage.

Finally, the Topcoat Sealer, 4100/4150 Acrylic Topcoat Sealer, is installed once the deck areas have been thoroughly cleaned. Apply the AVM Topcoat Sealer over the cured texture coat at the rate of 100-120 square feet per gallon. Allow the AVM Topcoat Sealer to cure for several hours. (Preferably 24 hours) If you cannot wait 24 hours, light foot traffic may be allowed when the AVM Topcoat Sealer is no longer tacky.

When installing the AVM System 100 Elasto Fiberdeck over plywood in conditions where wood framing ends and the system turns up the wall assembly, we would install edge metal a minimum of 2" from the edge of the wood framing. The metal lath and the AVM Crete 6400 would end prior to the edge metal. Acripatch 5020 is installed in a sloping fashion from the top of the AVM Crete 6400 and terminate 1" from the edge of the wood framing. We would then extend the membrane, texture and topcoat to the edge of the sheet metal flashing. Below is an isometric and section view of this detail.

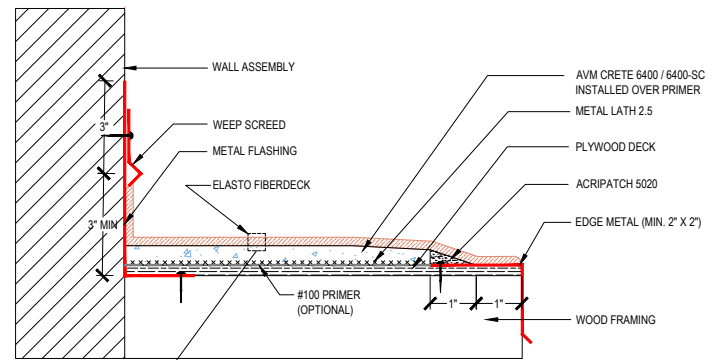
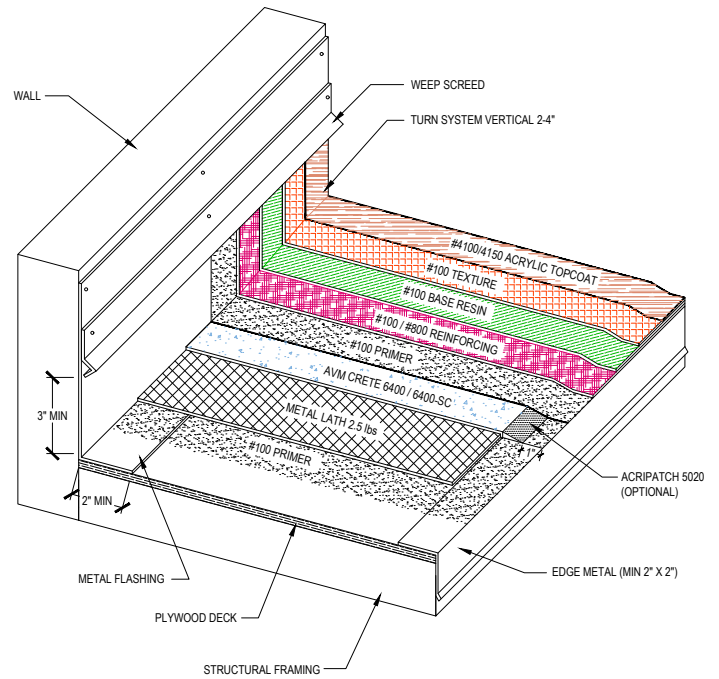

For stairs over plywood substrate, installation would depend on if there were tread only or if there were tread and riser. In inside and outside corners of the stairs, a 2" X 2" metal flashing would be used. For applications with tread only, the Metal Lath and AVM Crete 6400/6400-SC would only be installed over the horizontal stairs where we would see traffic. The tread nosing is attached to the edge of the stair by predrilling pilot holes and filling with Aussie Seal M before the fastener is placed into the hole with sealant. This is shown in the diagram below.

Installation Instructions

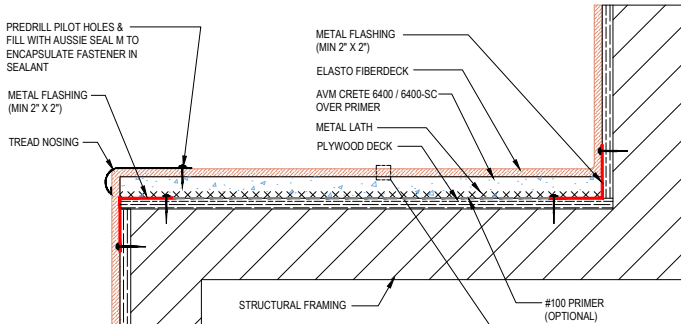

For installation of stairs over plywood where there is tread and riser, the AVM Crete 6400 would be installed over both the horizontal and vertical portions of the stairs. See below diagram.

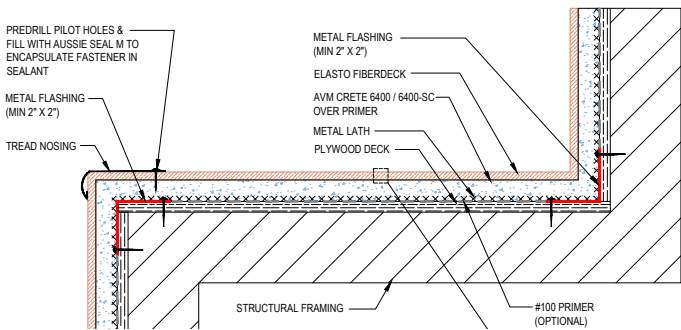

The threshold detail is going to be similar to the installation over concrete substrates but with the addition of the Metal Lath and AVM Crete 6400 as shown as follows.

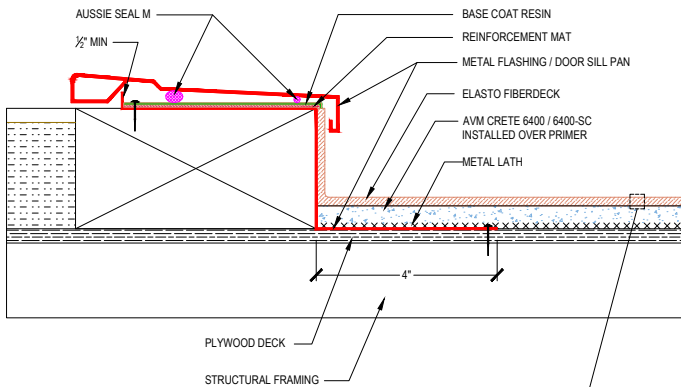

For drain assembly, we want to stop the AVM Crete 6400 at least 2" before drain opening leaving a minimum of 2" of exposed flange. Install the Acripatch 5020 to transition from 6400 to flange leaving a minimum 1" of flange exposed for direct membrane bonding. Ensure all drains sit low enough and that there is sufficient slope to properly drain the water. Remove all paints, primers, oils or foreign material on the drain flange by abrading / sanding to bare steel prior to full system application. Base resin may be installed into properly prepared drain bowl. Weep holes should not be blocked. See diagram below.

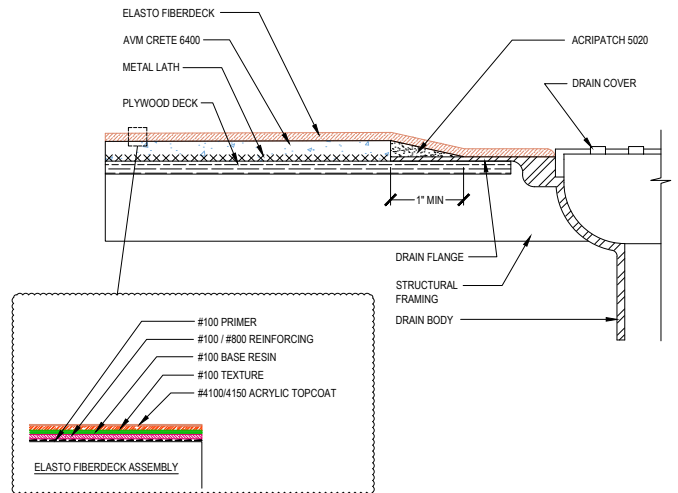

For sliding doors, we can do one of two approaches, where we can place reinforcement fabric under the metal lath and over the sill pan that extends 4" past the sill pan. The other option is to exclude the reinforcement fabric. See both options below.

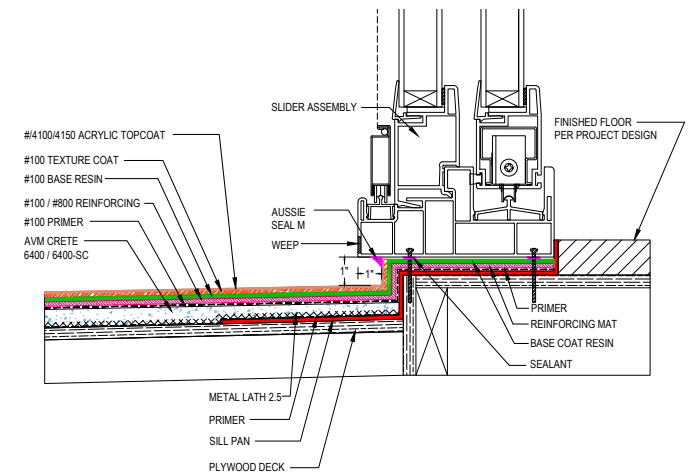

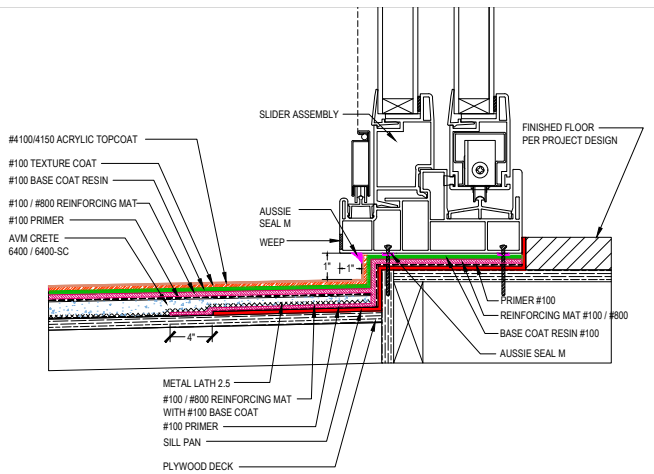

For additional detailing, please consult your local AVM Sales Representative or an AVM Technical Services Representative.

***NOTE: Please refer to the AVM Website for the latest details.**

REPAIRS

Follow the attached guidelines based on the type of damage on the installed AVM System 100 Elasto Fiberdeck system. Please contact AVM for project specific repairs.

Damage Description: Topcoat is stained, peeling, cracking or has aged. (Texture Coat is not damaged)

Method of Repair:

1. Scrape off any loose Topcoat using a scraper and/or a stiff brush.
2. Remove anything that might prohibit bonding of the new Topcoat Sealer. (High pressure washing is recommended)
3. Re-coat the damaged areas with new AVM Topcoat Sealer 4100.

For systems that have been installed for up to 12 months, a primer may not be required. Systems that have been installed more than 12 months prior to damage would require a primer. An upgrade to epoxy primer may be recommended depending on the conditions of the system and the extent of the damage. Contact AVM with questions.

Damage Description: Texture and Topcoat are damaged or peeling, yet the fiberglass membrane is not damaged.

Method of Repair:

1. Scrape off any loose texture or Topcoat using a scraper and a stiff brush.
2. Remove anything that might prohibit bonding of the new materials. (High pressure washing is recommended)
3. Apply new texture where needed.
4. Recoat the damaged areas with a new AVM Topcoat Sealer 4100.

Damage Description: The entire Elasto Fiberdeck 100 is damaged or peeling and the substrate is not damaged.

Method of Repair:

1. Scrape off any loose Elasto Fiberdeck® 100 coating using a scraper. You may also use a sharp knife to cut out and then peel off any bad sections. Make sure to remove all coating that is not securely bonded to the substrate below.
2. Remove/peel off anything that might prohibit bonding of the new materials. (High pressure washing is recommended)
3. Apply the new Elasto Fiberdeck® 100 system where needed.

Damage Description: The entire Elasto Fiberdeck 100 is damaged or peeling and the substrate is damaged.

Please reach out to AVM or an authorized installer to access and review damage prior to repair recommendations.

Installation Instructions

The following coverages are based on controlled tests. Actual coverages may vary.

Materials	One Kit Makes	One Kit Covers at 1/8" Thick	One Kit Covers at 1/4" Thick	One Kit Covers at 1/2" Thick
AVM Crete 6400	4 Gallons of Mixed Product	40 Square Feet	20 Square Feet	10 Square Feet
AVM Crete 6400 -SC	4 Gallons of Mixed Product	40 Square Feet	20 Square Feet	10 Square Feet
Weight of 1 sq. ft. of Crete 6400/6400-SC installed & cured		1 sq. ft. at 1/8" thick = -1.25 lbs.	1 sq. ft. at 1/4" thick = -2.50 lbs.	1 sq. ft. at 1/2" thick = -5.00 lbs.

Materials	Over Plywood	Over Concrete	Over Sheet Metal
AVM Primer 100 / Optional AVM Epoxy Primer 401 or 420	200-300 sq. ft./gal.	200-300 sq. ft./gal.	200-300 sq. ft./gal.
AVM Base Resin 100	40-50 sq. ft./gal.	40-50 sq. ft./gal.	40-50 sq. ft./gal.
AVM Mat 100 / Optional Mat 800	Allow 5%-10% waste	Allow 5%-10% waste	Allow 5%-10% waste
Texture Coat Sprayed Sand Finish	40-60 sq. ft./gal.	40-60 sq. ft./gal.	40-60 sq. ft./gal.
Texture Coat Sprayed Knock Down Finish	40-60 sq. ft./gal. depending on desired look	40-60 sq. ft./gal. depending on desired look	40-60 sq. ft./gal. depending on desired look
Texture Coat Troweled Smooth	35 sq. ft./gal.	35 sq. ft./gal.	35 sq. ft./gal.
AVM Top Coat Sealer 1st coat	100-120 sq. ft./gal.	100-120 sq. ft./gal.	100-120 sq. ft./gal.
AVM Top Coat Sealer 2nd Coat	150 sq. ft./gal.	150 sq. ft./gal.	150 Sq. ft./gal.

Technical Data - AVM System 100	
Fire Rating	Class A, 1 Hour
Weatherometer	No Cracking, Softening, Crazing
Wind Uplift (Tested/Approved)	135+ lbs./sq. ft., -227 MPH/90 MPH
Abrasion	4.58% (Pass)
Bond Strength (Once Cured)	134 PSI
Compressive Strength ASTM C39,C172,C192,C470 @ 28 Days	Crete 6400: 3700 PSI / Crete 6400-SC 2500 PSI
Impact Resistance, ASTM D-3746	No Cracking or Splits

General Data - AVM System 100	
Shelf Life: (Liquids)	One year in original unopened packaging.
Storage Conditions	Store dry at 50°-90°F. If frozen, discard
Crete 6400 Mixing	Pre-proportioned kit. 1-bag to 1-gal. additive
Crete 6400-SC Mixing	1-bag with 1 gal water
Crete 6400 Color	Gray
Base/Texture Colors	STD: Silver. Many custom colors available.
Top Coat Colors	Clear Sealer or See AVM's Color Chart Custom colors are available - Call for details.

Minimum Dry Thickness - Complete System: 0.310. (AVM Crete 6400/6400-SC must be at least 0.250" thick when dry)

Item/Component	Packaging	Approx. Shipping Weights	VOC
AVM AcriPatch 5020	2.0/5.0 gal. pails	2.0/5.0 gal. 15/39 lbs.	46 Grams/Liter
AVM Aggregate 400	50 lb. bag	50 lbs./bag	
AVM Aggregate 400-SC	50 lb. bag	50 lbs./bag	
AVM Additive 7400	2.0/5.0 gal. pails	2.0/5.0 gal. 18/46 lbs.	6 Grams/Liter
AVM Metal Lath 2.5#	10 sheets/bundle	5 lbs./sheet	
AVM Mat 100 / AVM Mat 800	1750 sq. ft. roll / 1080 sq. ft. roll	82.1 lbs. / 22.6 lbs.	
AVM Primer 100	2.0/5.0 gal. pails	2.0/5.0 gal. 18/46 lbs.	93 Grams/Liter
AVM Epoxy Primer 401 or 420	2.0 gal. kit / 2.4 gal. kit	26 lbs. / 26 lbs.	90 g/L / 0 g/L
AVM Base 100	2.0/5.0 gal. pails	2.0/5.0 gal. 18/46 lbs.	85 Grams/Liter
AVM Texture 100	2.0/5.0 gal. pails	2.0/5.0 gal. 23/58 lbs.	31 Grams/Liter
AVM TX-100	50 lb. bag	50 lbs./bag	
AVM Top Coat Sealer 4100/4150	2.0/5.0 gal. pails	19/47 lbs.	85/73 Grams/Liter

*NOTE: Technical Data is for reference only. Please refer to the AVM website for the current Technical Data Sheet and Safety Data Sheet.