

DETAIL #:  
0300-PLM-1120  
Aussie Shield 300-PLM

# Typical Penetration

Aussie Shield 300-PLM



SHEATHING PER PROJECT DESIGN

AUSSIE 300-PLF LIQUID FLASHING AT 15 MILS EXTENDING 2" ONTO SHEATHING AND 2" UP THE PIPE

AUSSIE 300-PLM LIQUID MEMBRANE AT 15 DRY MILS

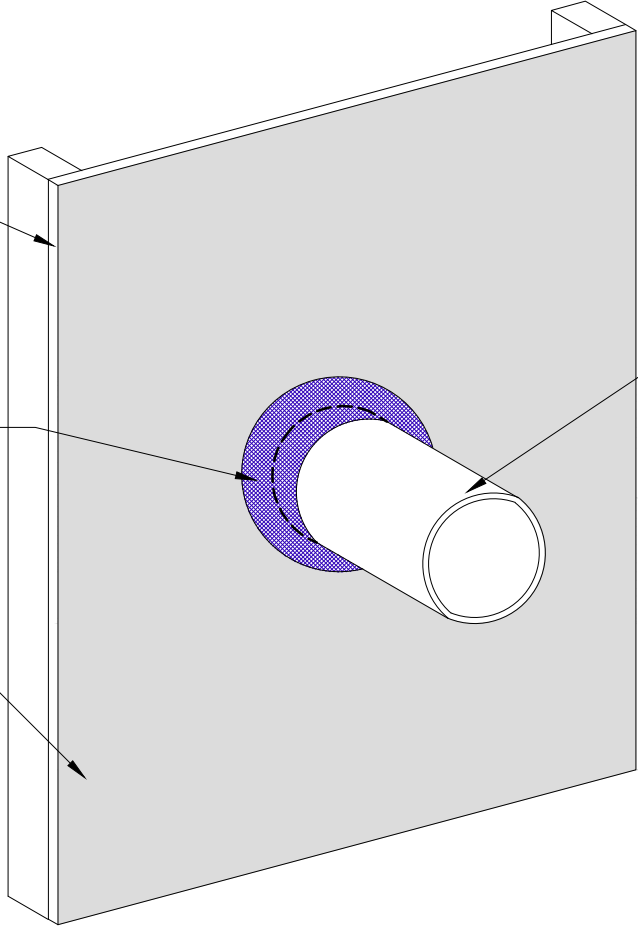

PIPE PENETRATION